

Kingspan Multibeam

Purlin & Rail Systems

Technical Handbook



Multibeam Evolved

Now in its fourth generation and with four decades of development, our highly evolved purlin and rail system is now **lighter** for easier site handling, **stiffer** for straighter cladding lines, **stronger** for longer spans and **greener** due to reduced steel content.

This means that it saves you time, lowers your costs and provides greater sustainability.



MULTIBEAM EVOLVED

Lighter | Stiffer | Stronger | Greener



Company Overview	2
Products Overview	4
Roof Purlins	6
Eaves Beams	48
Cladding Rails	62
Multichannel	94
Ordering Methods	132
Index	138

Foreword

Kingspan Structural Products are manufacturers of cold formed structural products, including Multibeam purlin and rail systems, Multideck composite steel floor decking, Multichannel sections and a comprehensive range of ancillary products on a fifty acre site in North Yorkshire.

In five decades of trading the company has become established as a market leader renowned for quality products and innovative design.



Kingspan Structural Products Manufacturing Complex

Kingspan Structural Products

Multibeam Purlin System

A range of purlin sections designed to suit all types of modern roof construction with bay sizes up to 15 metres.

Multibeam Cladding Rail System

A range of cladding rails designed specifically to support metal clad walls in horizontal or vertical applications on all kinds of main supporting structures.

Multichannel Steel Sections

A range of pre-engineered, structural channel sections designed to complement the Multibeam purlin and rail systems. Multichannel is an ideal solution for horizontally laid cladding and is particularly suitable for mezzanine floors, volumetric units. Multichannel can be an effective substitute for conventional hot rolled sections and timber. Unique pre-engineered end connections reduce components and simplify detailing.

Multideck Floor System

High performance, profiled, galvanised steel floor decking for use in the construction of composite floor slabs. The profile may also be used as a permanent shuttering. **This product is described in more detail in a separate technical handbook (ref P292).**

Commitment

It is our commitment and professional approach that has enabled the company to establish its outstanding reputation for service, quality and to maintain its lead in a highly competitive field.

Quality Assurance

Quality assurance is a fundamental feature of the Kingspan operating policy, from initial material testing for yield strength and thickness through to delivery on site. All aspects of quality and service are monitored ensuring compliance with the requirements of BS5750 Quality Systems.

SCILGA Accreditation

The Multibeam Purlin and Rail systems have achieved SCILGA accreditation. A copy of the accreditation certificate can be supplied if required.

Gold Standard

Kingspan Structural Products have been awarded the Gold Standard under the Steel Construction Sustainability Charter (SCSC).





Sustainability

The Multibeam system has been engineered to ensure maximum performance whilst minimising the material content. Individual sections are packed together using low carbon mild steel, blued and waxed banding which is wholly recyclable. Identification of the bundles is by paper labels which are biodegradable and can be recycled. Softwood bearers, used to support the bundles in transport are from managed woodland and are reusable.

Reuse

Steel does not lose its strength or stiffness over time so remains a viable product for reuse. Assembly joints between components can be easily dismantled at any time to facilitate reuse. Sections can be recut to length and reholed to suit a revised use.

Recycling

Steel is one of the world's most recycled materials with over 40% of 'new' steel made from recycled steel. Kingspan's suppliers encourage, promote and assist in the return of steel for recycling.



Certification

Kingspan Structural Products has developed a fully integrated management system which combines all the common elements of **ISO 9001 (Quality), ISO 14001 (Environment) and OHSAS 18001 (Occupational Health and Safety)** into one system.

This simple coherent business management system enables the organisation to successfully achieve its purpose and mission to ensure that quality; safety and the environment are considered in all aspects of the business process. Further information on these certifications can be found on our website

www.kingspanstructural.co.uk.

Customer Service

Experience

From concept and design to manufacture and site installation, Kingspan Structural Products has an unmatched degree of experience with over four decades of experience and technical expertise in all aspects of steel construction. With Multibeam now in it's fourth generation, Kingspan remain focused on servicing the ever changing need of the construction industry.

Technical Excellence

At Kingspan Structural Products we are committed to advancing technology within the construction industry. Working in conjunction with the world's leading experts, continually refining and testing new and existing products, while enhancing our reputation for technical excellence and the establishment of higher standards in the industry.

Specialist Team

Kingspan offer a comprehensive advisory service to customers, specifiers and contractors on all aspects of specification and use of our product range.

Our specialist team of design engineers is available to answer technical queries regarding the use of our products in any application. Our internal sales staff and customer services department provide a friendly and efficient service from initial enquiry through to site delivery and after sales.

Area Sales Managers

Personal contact is important. Our specially trained regionally based Sales Managers are on hand to discuss your project personally and advise on the application and use of Kingspan Structural Products.

Our Area Sales Managers are also trained to install and update our time saving Toolkit design software. Toolkit is available to all specifiers and users of our product range, as part of our comprehensive service package.

Products Overview

With simple connections and economical sections, **Eaves Beam** is compatible with all types of cladding in modern roof construction

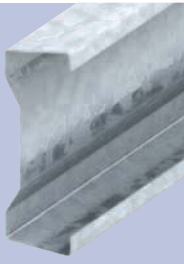

Multibeam Purlin and Rail System typically requires fewer components than other systems. This means quicker assembly and faster project completion.

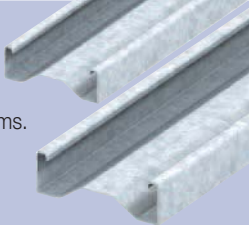

Multichannel System can be used for a myriad of applications such as horizontally laid cladding rails, gable posts, door and window trimmers and floor joists.

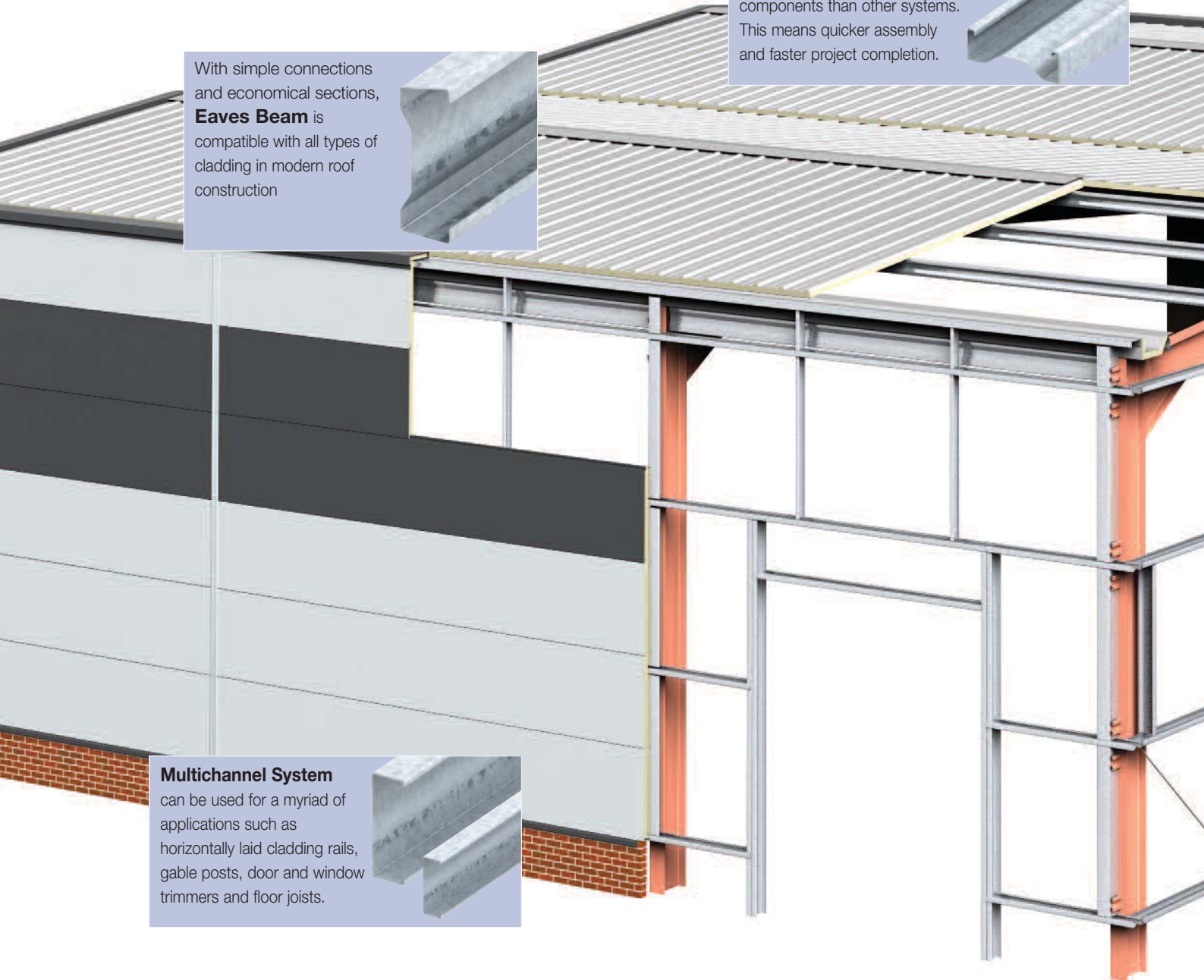

You can't get it wrong
with multibeam purlins;
The unique sigma shape
is "non-handed",
making it the most
versatile purlin on
the market today.



Multideck

composite floor slab decking system can save up to 20% on concrete costs, when compared with other deck profiles.

Please see our separate technical handbook (ref P292).

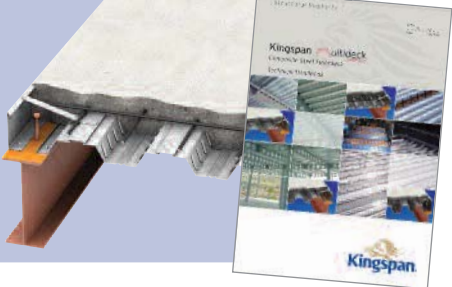



MULTIBEAM EVOLVED

Lighter | Stiffer | Stronger | Greener



Roof Purlins

Overview	8
Spanning Systems	9
Anti-Sag Requirements	10
Purlin Restraints	12
Construction Details	16
Product Dimensions and References	24
Section Properties	32
Load Tables	33

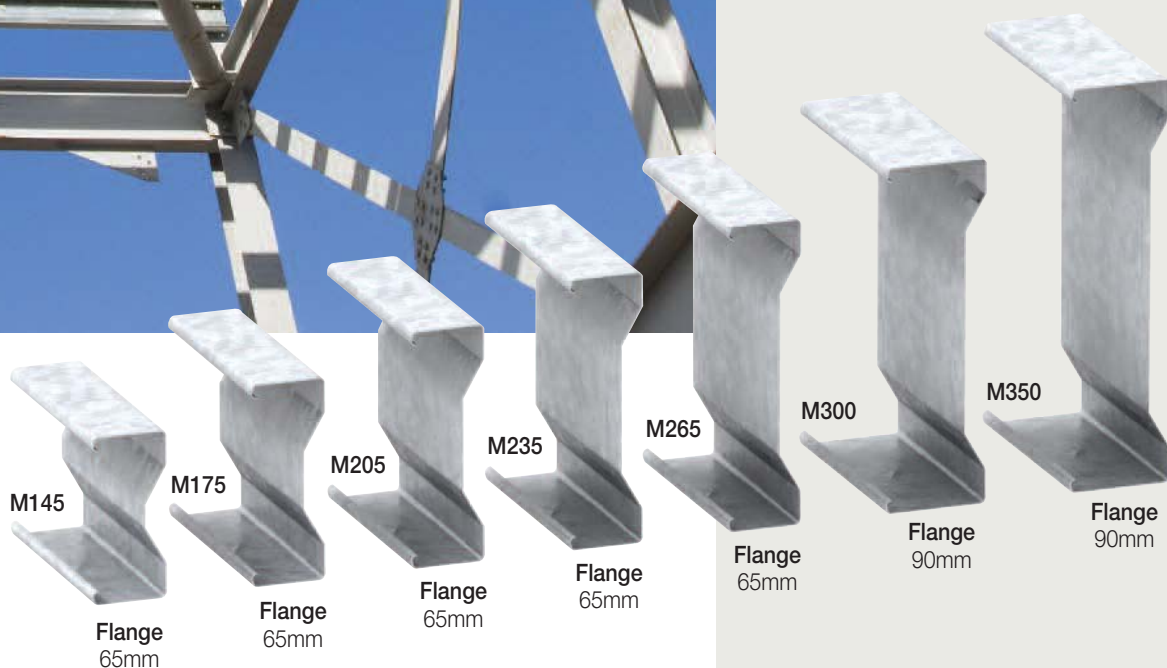

Multibeam Roof Purlins - Overview

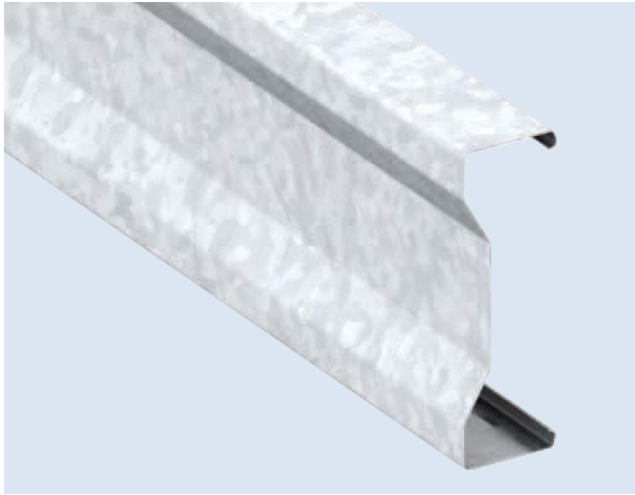

Applications

- All types of roof cladding
- Pitched, mansard, curved or flat roof applications
- Roof slopes from 0° to 60°
- Bay widths up to 15m

Material Specification

Hot dip galvanised steel to BS EN 10326:2004 and BS EN 10143:1993 'specifications for continuously hot dip zinc/metal coated structural steel strip'.

The minimum grade of steel used is **S450GD**, with Z275 zinc coating, giving an average coating thickness of 0.02mm to each side. Other galvanised coatings may be available.

Please contact our Technical Department for advice.

Sustainability

The Multibeam system has been engineered to ensure maximum performance whilst minimising the material content.

Individual sections are packed together using low carbon mild steel, blued and waxed banding which is wholly recyclable.

Identification of the bundles is by paper labels which are biodegradable and can be recycled.

Softwood bearers, used to support the bundles in transport are from managed woodland and are reusable.

Reuse

Steel does not lose its strength or stiffness over time so remains a viable product for reuse. Assembly joints between components can be easily dismantled at any time to facilitate reuse. Sections can be recut to length and reholed to suit a revised use.

Recycling

Steel is one of the world's most recycled materials with over 40% of 'new' steel made from recycled steel. Kingspan's suppliers encourage, promote and assist in the return of steel for recycling.



Certification

Kingspan Structural Products has developed a fully integrated management system which combines all the common elements of **ISO 9001 (Quality)**, **ISO 14001 (Environment)** and **OHSAS 18001 (Occupational Health and Safety)** into one system.

This simple coherent business management system enables the organisation to successfully achieve its purpose and mission to ensure that quality; safety and the environment are considered in all aspects of the business process. Further information on these certifications can be found on our website www.kingspanstructural.co.uk.

Range

- Section heights from 145mm to 350mm
- Flange widths from 65mm to 90mm
- Gauges from 1.2mm to 2.7mm

For full product dimensions see page 24. Other sizes may be available on specific request. Please contact our Technical Department for advice.

Lengths

- All lengths are catered for; requirements in excess of 18m, please contact our Sales Department.

MULTIBEAM EVOLVED

“ The new improved sigma shape of Multibeam makes it stiffer than other common shapes of purlin so it can be handled practically on larger spans ”

Spanning Systems

Multibeam can be used in all the popular and economic purlin spanning systems. The enhanced stiffness of the Multibeam shape makes it ideal for all span dimensions from the very short to the very long with purlin bar lengths of 18m or more, making it practical for both handling and structural performance.

Sleeves

Sleeves are used to provide continuity at the joints between members and are available in three gauges (see page 28). When joining two sections of different gauges (as in a HEB system) use the heaviest gauge purlin to select the sleeve for that joint.

Double Span

Double span lengths of Multibeam section span across three frame supports and provide design economy and speed of erection. This spanning system always results in the lowest component count. To ensure equal load distribution across the supporting steel work the joints are staggered, typically requiring only one sleeve per run of purlins.

Most double span bar lengths can be provided, although bays over 9m generally use single span lengths and are sleeved at every other joint to maintain continuity. Multibeam can be supplied in various lengths, please check with our Sales Department for lengths over 18m.

Use double span system where possible
 • fewer components!
 • quicker to erect!

Continuous Span (HEB)

This system is often referred to as Heavy End Bay "HEB" because a thicker gauge of section is required in the end bays of the building, although all internal bays are a lighter gauge. With this system all purlin joints are sleeved although double span bar lengths may be used to reduce sleeve numbers. The continuous system when used on larger buildings with bays larger than 6.5m may result in lower material cost, but more complex and costly erection.

System Types

Double Span

- Most popular system
- Ideal for all bay centres up to and including 9m
- Lowest component count
- Quicker erection and programme completion

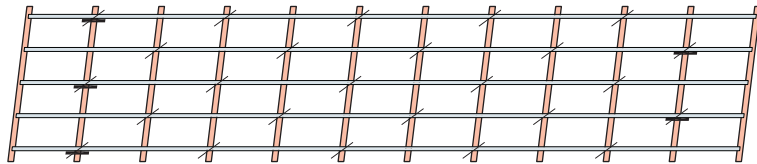

Double Span - Heavy End Bay

- Suitable alternative to double span system, for bay centres between 6.5m and 9m
- Appropriate for buildings of 10 bays or more
- Efficient material usage
- Moderate component count

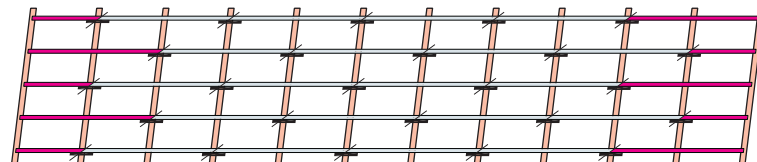

Single Span Sleeved Joints

- Option for all bay sizes particularly those with bay centres greater than 9m
- Where site restrictions (access, weight, craning etc.) dictates use of single span length
- High component count
- Normal double span load tables can be used

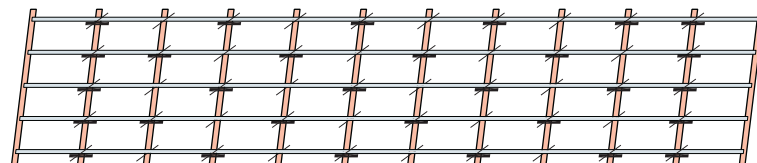

Single Span - Heavy End Bay

- Suitable alternative to single span sleeved system, for bay centres greater than 9m
- Where site restrictions (access, weight, craning etc.) dictates use of single length
- Highest component count
- Appropriate for buildings of 10 bays or more

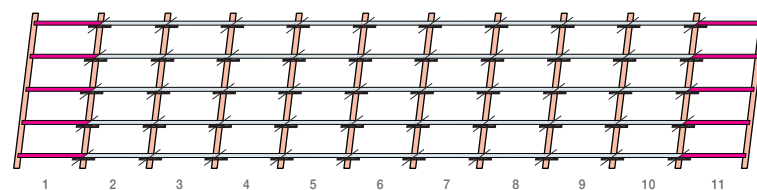

NB: Diagrams shown above are as plan view on the roof slope.

■ Heavier end sections indicated ■ Sleeve / Joint

Anti-Sag Requirements

Multibeam purlins do not require anti-sag ties on popular spans (up to 6.1m and roof slopes 10° or less).

Multibeam purlins on popular spans do not generally require anti-sag ties. In certain circumstances such as wind reversal conditions, large bay sizes or cladding systems that do not provide lateral restraint, then anti-sag ties may be required. Please refer to table 1:1 or the Kingspan Toolkit Software.

Table 1:1 Anti-Sag requirements for differing bay centres at varying roof slopes

Roof Slope	Multibeam Purlin Section Depth (mm)	Bay Centres							
		<3.0	>3 - 5.1m	>5.1 - 6.1m	>6.1 - 7.0m	>7.0 - 8.2m	>8.2 - 9.1m	>9.1 - 10.5m	>10.5 - 12m
< 3°	All	See flat roofs page 15.							
3°-10°	145	NO ANTI-SAG TIES REQUIRED				1 Multilok	2 Multilok	N/A	N/A
	175	NO ANTI-SAG TIES REQUIRED				1 Tubular	1 Tubular	2 Tubular	3 Tubular
	205	NO ANTI-SAG TIES REQUIRED				1 Tubular	1 Tubular	2 Tubular	3 Tubular
>10°-15°	235	N/A	N/A	N/A	N/A	N/A	2 SW Angle Struts	3 SW Angle Struts	3 SW Angle Struts
	265	N/A	N/A	N/A	N/A	N/A	2 SW Angle Struts	3 SW Angle Struts	
	300	N/A	N/A	N/A	N/A	N/A	2 SW Angle Struts	3 SW Angle Struts	
>15°-18°	350	N/A	N/A	N/A	N/A	N/A	2 SW Angle Struts	3 SW Angle Struts	3 SW Angle Struts
	145	NO ANTI-SAG TIES REQUIRED	1 Multilok	1 Multilok	1 Multilok	1 Multilok	2 Multilok	N/A	
	175	NO ANTI-SAG TIES REQUIRED	1 Tubular	1 Tubular	1 Tubular	1 Tubular	2 Tubular	3 Tubular	
> 18°	205	NO ANTI-SAG TIES REQUIRED	1 Tubular	1 Tubular	1 Tubular	1 Tubular	2 Tubular	3 Tubular	3 SW Angle Struts
	235	NO ANTI-SAG TIES REQUIRED	1 Tubular	1 Tubular	1 Tubular	1 Tubular	2 Tubular	3 Tubular	
	265	NO ANTI-SAG TIES REQUIRED	1 Tubular	1 Tubular	1 Tubular	1 Tubular	2 Tubular	3 Tubular	
> 18°	All	Consult Kingspan							

For roof slopes of 30° and over consider using stiffened purlin cleats.

General Notes

The information in the table above can be affected by the types of roof cladding used. Please see page 12 for more info.

Roof Slopes Over 18°

For roof slopes outside those shown above consult our Technical Department. Stiffened purlin cleats should always be used for Roof Slopes over 30°.

Long Roof Slopes

For roof slopes exceeding 20m long, diagonal wires may be required to support the downslope component of the load.

Multilok Ties

Multilok ties are generally used on purlin sections up to 205mm deep.

Temporary Propping

When no anti-sag ties are used temporary spacers and propping may be required during sheeting of the roof.

Mono Pitch

Diagonal wires generally required to support downslope load. Contact Kingspan technical for further information.

Apex Ties

Apex Ties must be used in all cases where anti-sag ties are required. On bays >6.1m when no anti-sag ties are used we recommend that apex ties are used, to provide stability during sheeting of the roof.

Anti-sag

Anti-sag requirements assume that there are two slopes with a central ridge. On roof slopes of 6° or more, over 20m in length, we recommend that wire ropes are considered within the slope length to limit the load applied to the apex tie. See page 23 for construction details.

Load Tables and Structural Properties

For best results please use the Toolkit Design Software. Alternatively the ultimate loads to BS5950:Part5:1998 can be found on page 33.

Spans

Multibeam sections can be used on spans up to 15m. Please consult our Technical Department for more information.

Typical Tubular Tie Arrangement

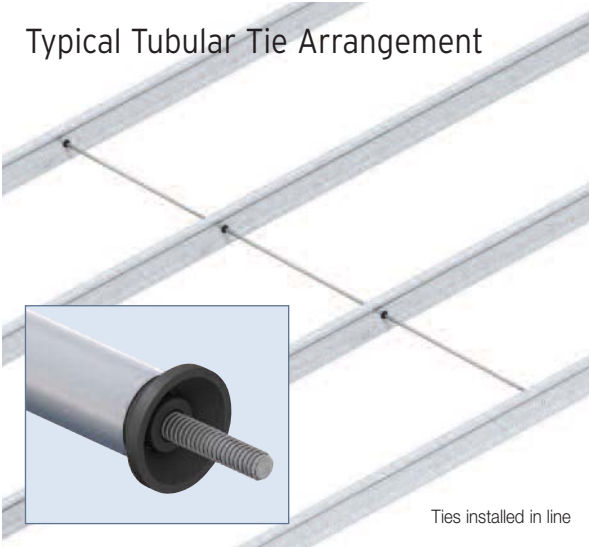

Typical Angle Strut Arrangement

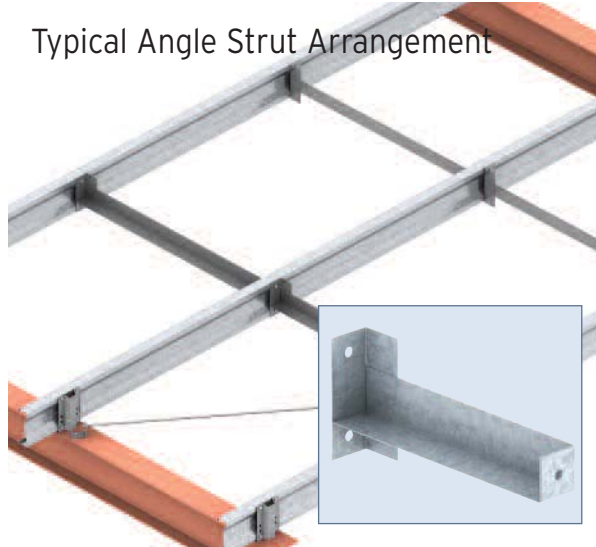

Typical Multilok Tie Arrangement
M145 Purlin sections

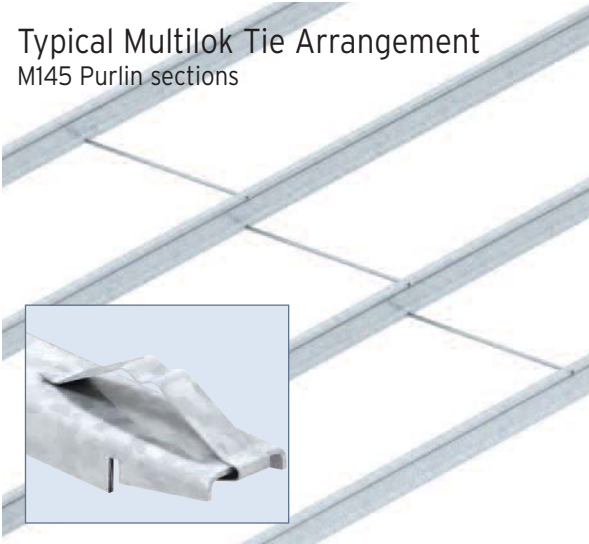

Typical Multilok Tie Arrangement
M175 and M205 Purlins

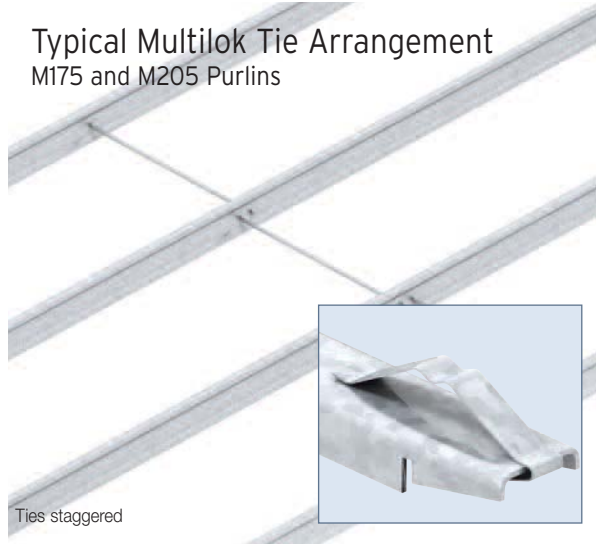







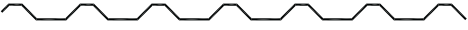
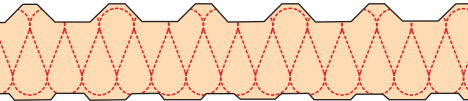

For details on hole groups please go to page 135.

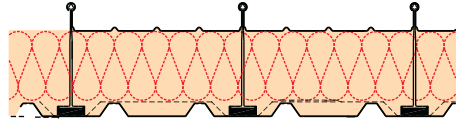
Purlin Restraint

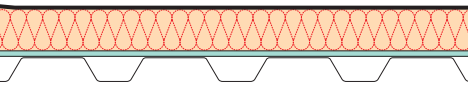
Multibeam purlins can be used with all types of modern roof cladding systems including metal composite panels, standing seam, insulated membrane panels, and traditional tiles. However, it should be noted that certain types of roof cladding do not give the necessary lateral restraint to purlins and additional restraints may be required. Please consult Table 1:2 for guidance.

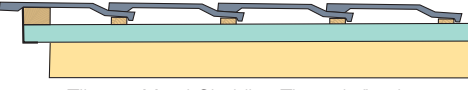
Table 1:2 Restraint requirements for various types of roof cladding

Type of roof cladding	Provides lateral restraint	Load Table
 <p>Trapezoidal Single Skin</p>	Yes	Use normal load tables
 <p>Trapezoidal Twin Skin Through fixed liner</p>	Yes	Use normal load tables
 <p>Composite Clip Fixed Standing Seam (eg. KingZip)</p>	Yes	See additional information opposite
 <p>Twin Skin Clip Fixed Standing Seam (With through fix liner)</p>	Yes	Use normal load tables (check liner provides lateral restraint)
 <p>Composite Panel Through Fix (eg. Kingspan KS1000RW)</p>	Yes	Use normal load tables
 <p>Built Up Flat Roof</p>	Yes (if through fix deck used) (see page 15)	Use normal load tables
 <p>Composite Membrane Panel (eg. Ward Topdek)</p>	Yes (see page 15)	Use normal load tables
 <p>Tiles</p>	No (see page 14)	(see page 37)
 <p>Tiles on Metal Cladding Through fixed</p>	Consult Kingspan	Consult Kingspan
 <p>Roof Tile Insulated Panel (eg. Kingspan Rooftile)</p>	Consult Kingspan	Consult Kingspan

This table is for guidance only. Please consult individual cladding manufacturer's recommendations and your cladding supplier for suitability of lateral restraints.

Restraint Information

Roofing systems - Through fix

Built-up Roofing

Generally comprises of a trapezoidal outer weather sheet, insulation, spacers and an inner liner sheet all assembled on site.

Where the profiled liner sheet is steel with a minimum gauge of 0.4mm using self tapping screws at maximum cross centres of 350mm, then adequate restraint is provided to the Multibeam purlins to enable the published load tables to be supported. Restraints as table 1.1, page 10.

Where there is no steel liner sheet through fixed to the purlin, additional restraints must be provided as shown in table 1.3 to enable the published load tables to be supported.

Where a liner sheet is provided but it is not of steel construction then please consult our Technical Department, or provide the restraints as shown in table 1.3 to enable the published load tables to be supported.

Insulated panels

A factory manufactured composite panel, comprising of steel and insulation eg. Kingspan KS1000RW/Ward IP1000.

When these panels are fixed to the purlin top flange using through fix self tap, self drilling screws, three number per panel, then adequate restraint is provided to the Multibeam purlins to enable the published load tables to be supported. Restraints as table 1.1, page 10.

Roofing systems - Secret and Clip fix

A specialised form of built up roofing system where the outer weather sheet has a side seams that stands above the water trough. These systems will have a weather sheet, halters, spacer, insulation and a profiled liner sheet.

Clip Fix

Where the outer sheet is free to move and through fixed steel liner minimum gauge 0.4 or 0.9mm aluminium liner using self drill, self tapping screws at a maximum cross centres of 350mm, then adequate restraint is provided to the Multibeam purlins to enable the published load tables to be supported. Restraints as table 1.1, page 10.

Clip fixed, where the outer sheet is free to move and no steel liner then restraints must be provided as shown in table 1.3 to enable the published load tables to be supported.

Secret fix insulated panels

Factory manufactured composite panel of steel and insulation eg Kingspan KS1000LP/Ward DR1000.

Through fixed self drill, self tapping screws are placed on the raised shoulder at the edges of the panels and the fixing covered with a snap on cap. The two fixings placed each side of the panel will provide adequate restraint to the Multibeam purlins. Restraints as table 1.1, page 10.

Down slope ties

Where the outer weather sheet is free to move and there is no liner sheet or the liner sheet is not adequate to support the down slope load, then the tie arrangement shown to the right must be adopted.

Table 1:3 Restraint requirements for built-up cladding without a liner panel

Multibeam Purlin Section Depth (mm)	Purlin Span up to 6.1m	Purlin Span >6.1m – 8.1m	Purlin Span >8.2m – 9.1m	Purlin Span >9.1m – 11.1m
145	1 Tubular Tie	N/A	N/A	N/A
175	1 Tubular Tie	2 Tubular Ties	N/A	N/A
205	1 Tubular Tie	2 Tubular Ties	3 Tubular Ties	N/A
235	1 Tubular Tie	2 Tubular Ties	3 Tubular Ties	3 SW Angle Struts
265	1 Tubular Tie	2 Tubular Ties	2 SW Angle Struts	3 SW Angle Struts
300	1 SW Angle Strut	2 SW Angle Struts	2 SW Angle Struts	3 SW Angle Struts
350	1 SW Angle Strut	2 SW Angle Struts	2 SW Angle Struts	3 SW Angle Struts

Plan view

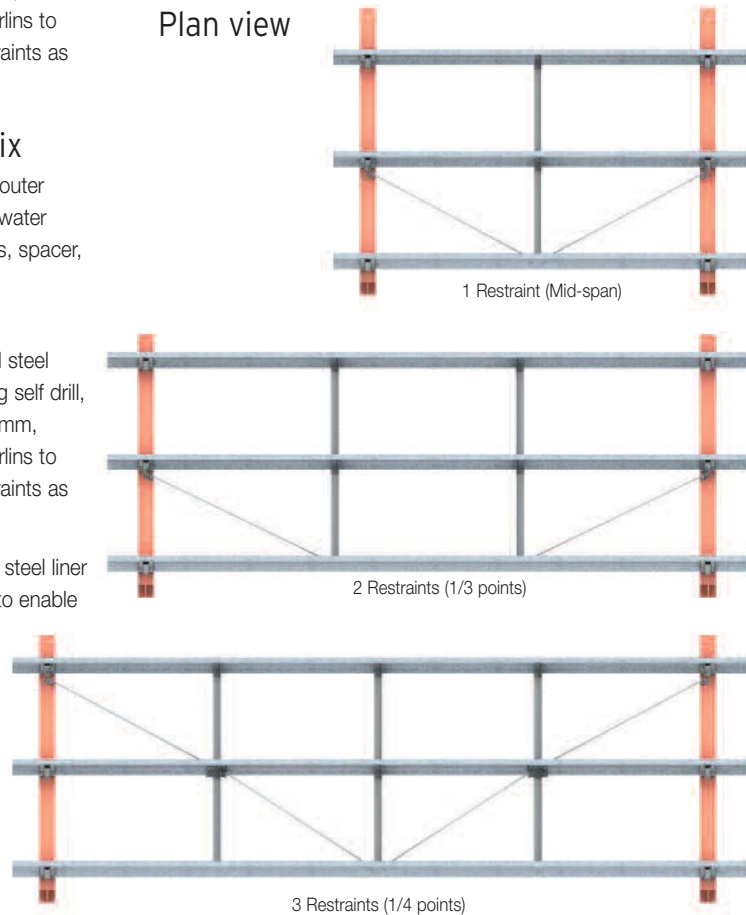

Purlin Restraint (Continued)

Tiled Roofs

The shape and strength of the Multibeam section is eminently suitable to sustain the greater loadings imposed by a tiled roof. However, due to the nature of the forces imposed upon the purlin sections by this form of roof construction, additional considerations are required in the design of the purlin.

Angle Strut Anti-Sag System

The angle strut brace system caters for the downslope force produced in the roof from dead and superimposed loads. The section capacities are based on using an anti-sag system with restraints at a minimum of 1/3 points and a minimum angle of 30° on the screwed rods. Table 1.4 shows the max spans achievable for this combination with the cross centres of purlins shown. Where the span is curtailed by the minimum 30° angle of the diagonal rods, place the restraints at 1/4 points as shown in table 1.4.

One set of diagonals are required for every 6.0m length of roof slope. As long as this is complied with the roof slope can be any length. Stiffened cleats should also be used with tiled roof construction.

Anti-Sag requirements with metal liner

When certain cassette metal liner profiles are fixed to the purlin top flange, enough restraint may be provided in order to use the standard load tables in conjunction with the anti-sag system. For further advice please contact our Technical Department.

Table 1:4 Max Purlin spans for tiled roof applications

Purlin Cross Centres (m)	Maximum span of purlin ¹ Restraints at 1/3 points (m)	Maximum span of purlin ¹ Restraints at 1/4 points (m)
0.6	3.10	4.10
1.0	5.10	6.90
1.5	7.02 ²	7.02 ²
1.8	7.02 ²	7.02 ²

¹ span limited by minimum angle of diagonal of 30°

² span limited by load maximum see page 37. For values outside of table please contact our Technical Department.

Roof Lights

Where the roof lights are laid in scatter pattern between adequately fixed roofing then the restraints required are classed as for the roofing system.

Where domed roof lights are used in strips across the purlins, down slope framed on either side with full roof sheeting the restraints are classified as for the roof system.

Laying roof lights in continuing strips along the purlins should be avoided as this construction may not provide the required level of restraint to the purlin. Please contact our Technical Department for guidance.



Plan view

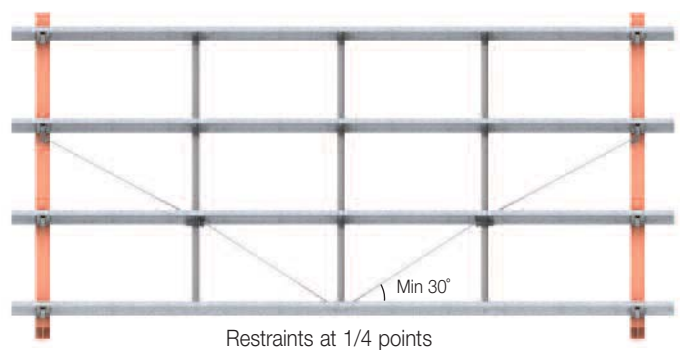
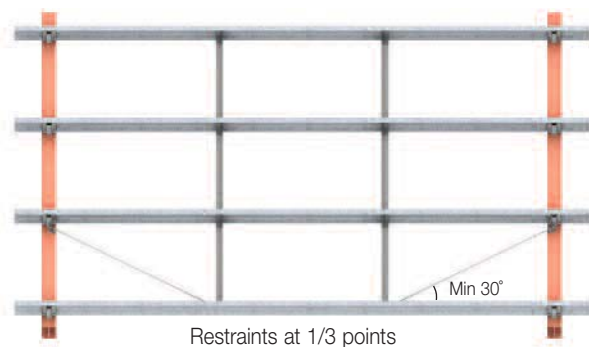

Low pitch and flat roofing system

(Roof slopes 3° or less)

For this application the term 'Flat Roof' generally means any roof with a roof slope no greater than 1:20 or 3°.

Built up Standing Seam roofing systems

A specialised form of built up roofing system where the outer weather sheet has a side seam that stands above the water trough. These systems will have a weather sheet, halters, spacers, insulation and a liner sheet. Typically this system can be classed as clip fixed where the outer sheet is free to move or is fixed.

Where the outer sheet is free to move and through fixed profiled steel liner minimum gauge 0.4mm using self drill, self tapping screws at a maximum cross centres of 350mm, then adequate restraint is provided to the Multibeam purlins to enable the published load tables to be supported. Restraints as table 1.5.

Clip fixed, where the outer sheet is free to move and no steel liner then restraints must be provided as shown in table 1.3 on page 13 to enable the published load tables to be supported.

Down slope ties

Where the outer weather sheet is free to move and there is no liner sheet or the liner sheet is not adequate to support the down slope load, then the tie arrangement shown below must be adopted.

Secret fix insulated panels

(eg Kingspan KS1000LP/Ward DR1000).

Through fixed self drill, self tapping screws are placed on the raised upstands at the edges of the panels and the fixing covered with a snap on cap. The two fixings placed each side of the panel will provide adequate restraint to the Multibeam purlins.

Restraints as table 1.5.

Table 1:5 Restraint requirements for flat roofs

Multibeam Purlin Section Depth (mm)	Purlin Span up to 6.1m	Purlin Span >6.1m – 7.5m	Purlin Span >7.5m – 9.1m	Purlin Span >9.1m – 11.1m
145	Tie not required	N/A	N/A	N/A
175	Tie not required	1 Tubular Tie	2 Tubular Ties	N/A
205	Tie not required	1 Tubular Tie	2 Tubular Ties	N/A
235	1 Tubular Tie	1 Tubular Tie	2 Tubular Ties	3 SWF Angle Struts
265	1 Tubular Tie	1 Tubular Tie	2 Tubular Ties	3 SWF Angle Struts
300	1 SWF Angle Strut	1 SWF Angle Strut	2 SWF Angle Struts	3 SWF Angle Struts
350	1 SWF Angle Strut	1 SWF Angle Strut	2 SWF Angle Struts	3 SWF Angle Struts

Note: Layout details on page 20

Built up membrane flat roof system - deck based

A trapezoidal steel deck is fixed directly to the Multibeam purlins using self drill, self tapping screws. A layer of board insulation is placed on top of the deck and attached, plus an impermeable membrane is laid over the insulation and bonded or held in place by ballast. The deck is generally fixed at every trough to the purlin and will then provide sufficient restraint to support the published load tables if the secondary restraints are as shown in table 1:5.

Insulated panel – Membrane insulated roof system

(eg Ward Topdeck).

A special fixing technique allows the attachment screws to fix the inner steel deck profile directly to the purlin, providing adequate restraint to support the published load tables when the restraints as shown in table 1:5 are used.

Purlin deflection limits

Deflection limits are generally given greater attention on low pitched and flat roofs to avoid excessive ponding of water.

Tie Arrangements

Where the arrangements for cladding systems that do not provide restraints, eg, standing seam.

Bay centres up to 8.2m

One strut at Mid-span

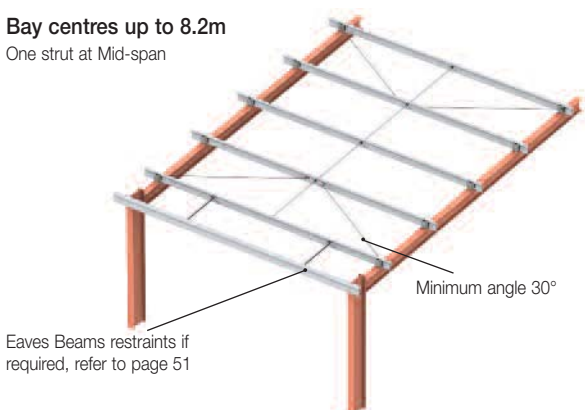

Bay centres >8.2m – 9.1m

Two struts at third points

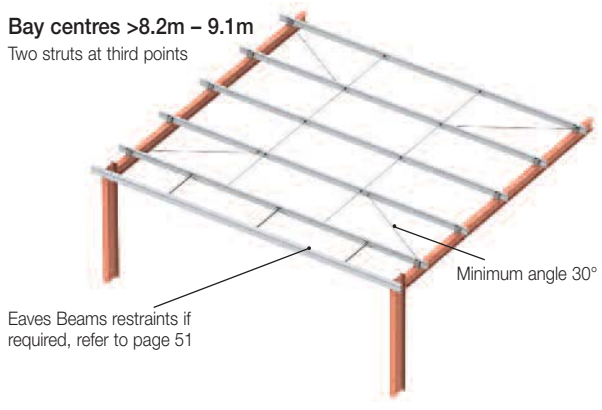

Construction Details - Purlin System

Weld-on Multicleat

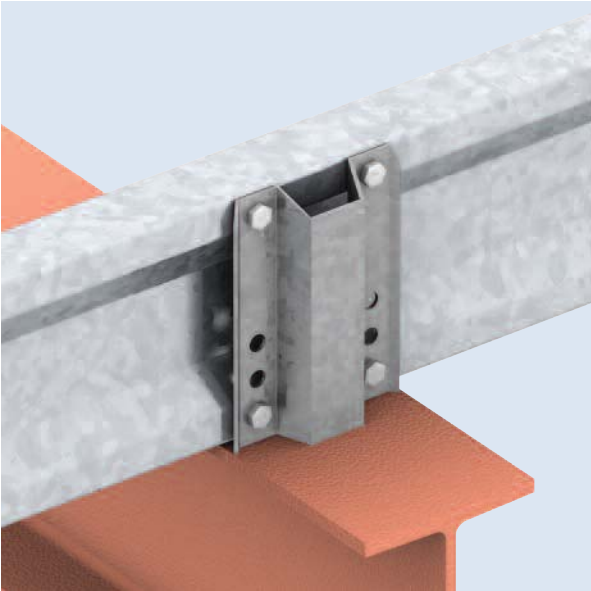

For product dimensions refer to page 25.

Bolt-on Multicleat

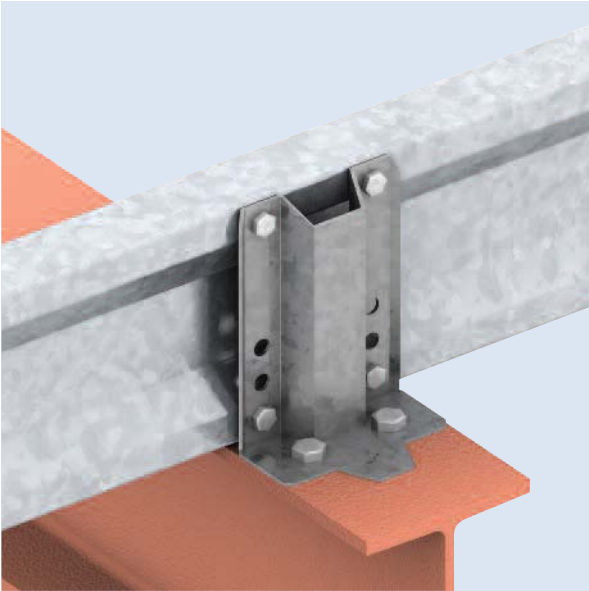

For product dimensions refer to page 25.

Stiffened extended cleat*

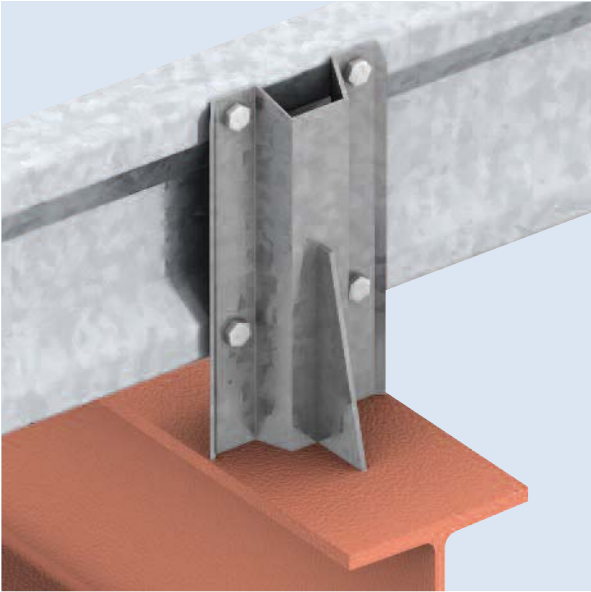

For product dimensions refer to page 27.

Multicleat with raised section*

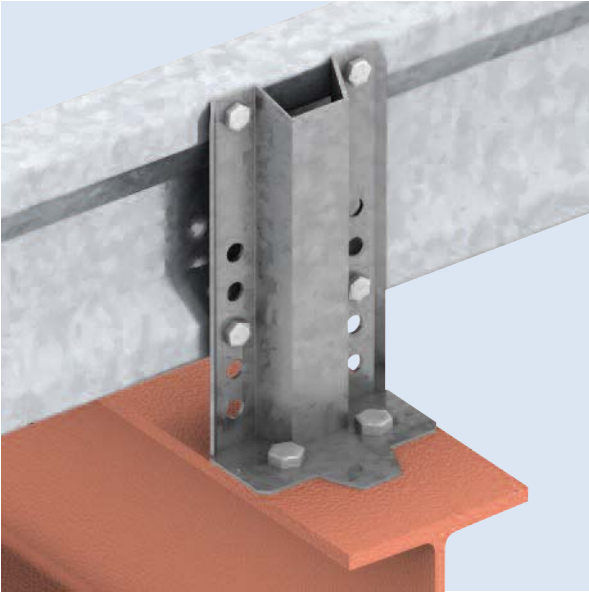

For product dimensions refer to page 25.

* Available in weld or bolt-on variations.

Purlin Sleeve

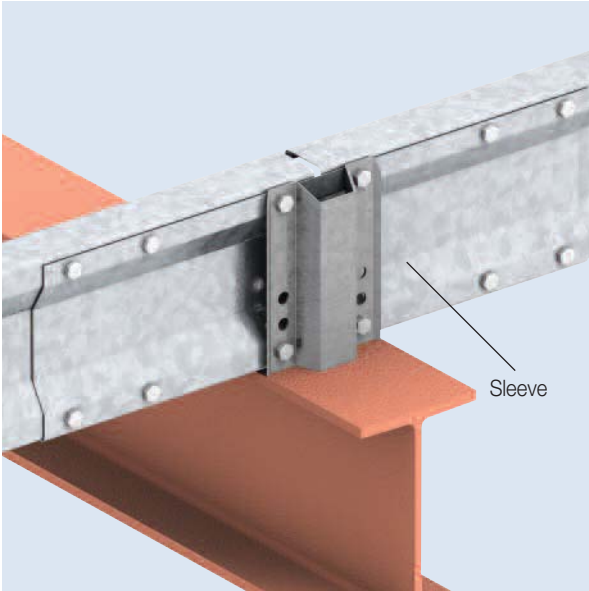

Sleeve Hole Dimensions

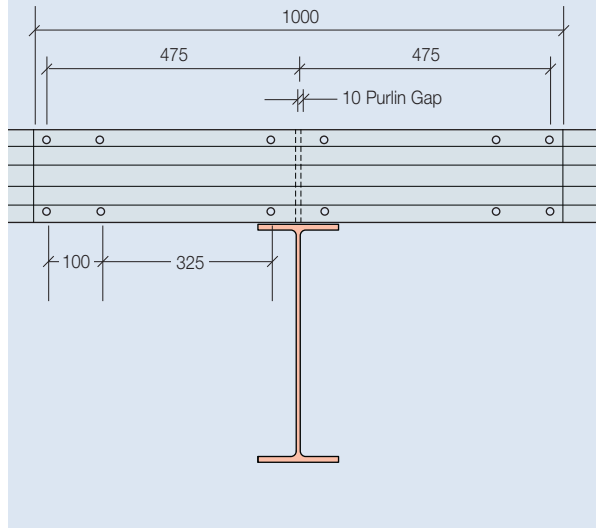

For product dimensions refer to page 28.

Cantilever with Stub

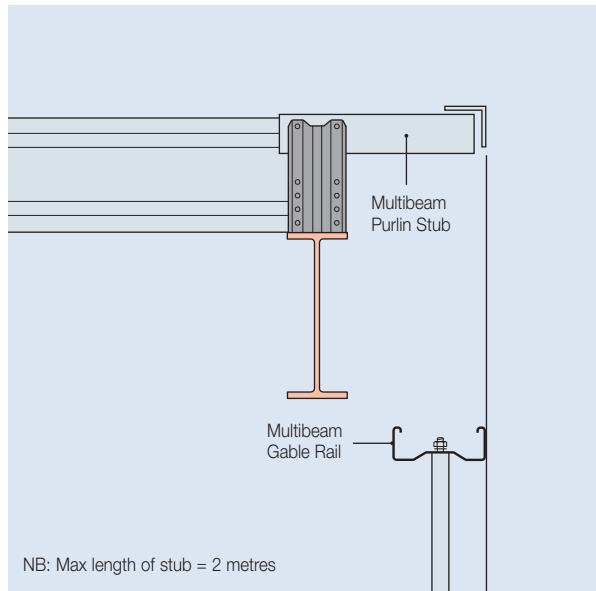
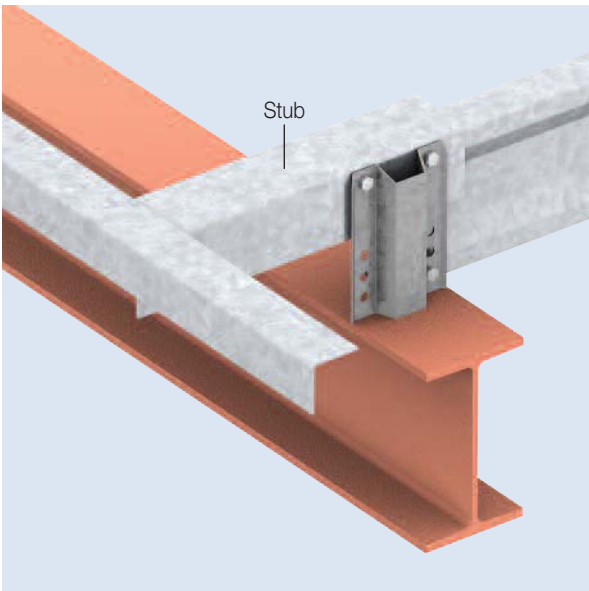

Construction Details - Purlin System

Cantilevered Purlin with Sleeve

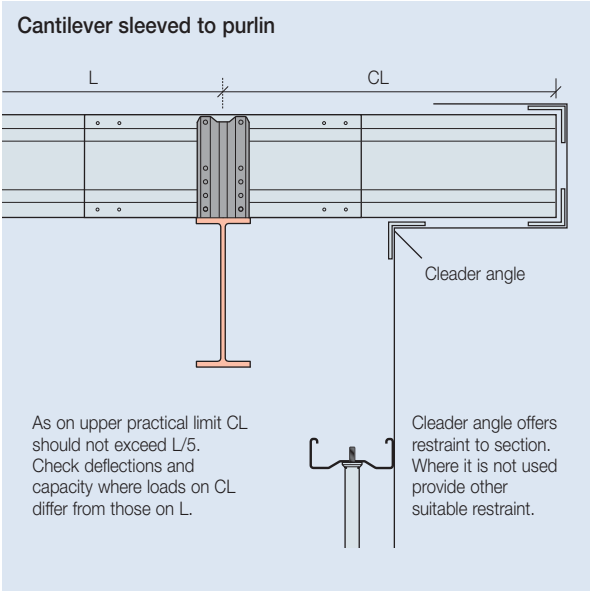
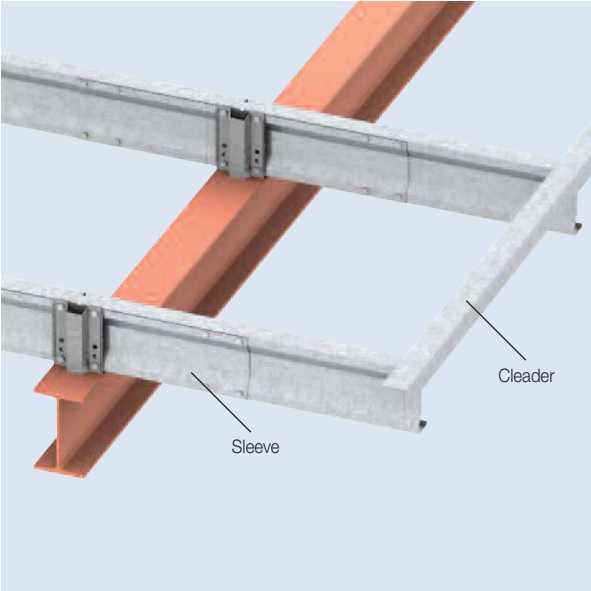

For product dimensions refer to pages 28 and 31.

Cantilevered Purlin without Sleeve

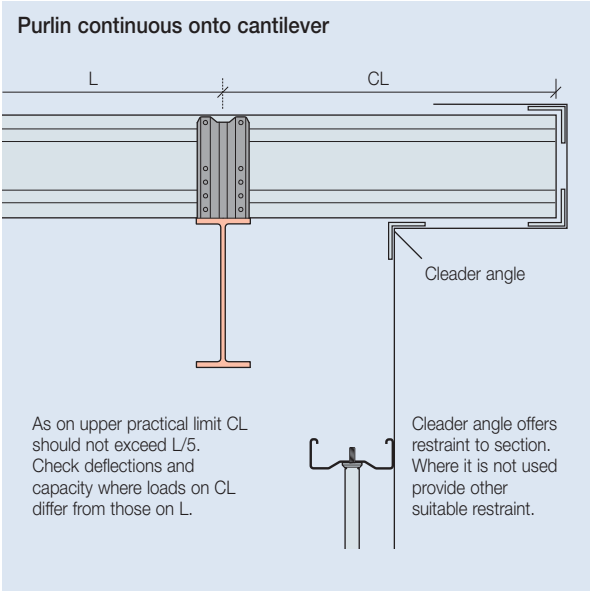
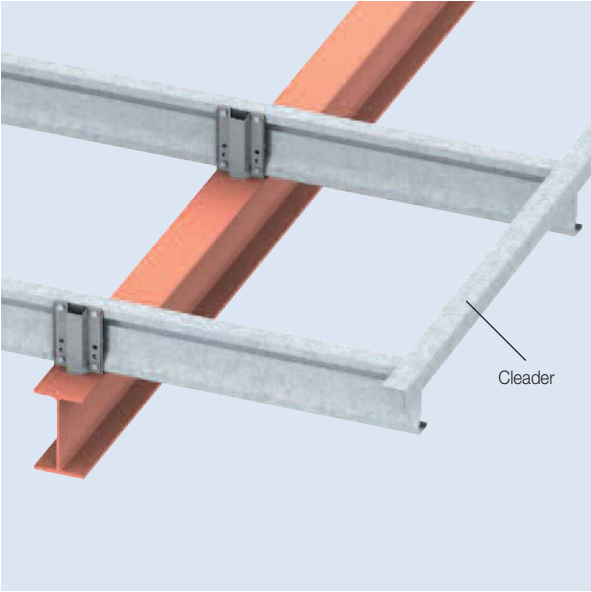

For product dimensions refer to page 31.

Rafter Stay type RNA

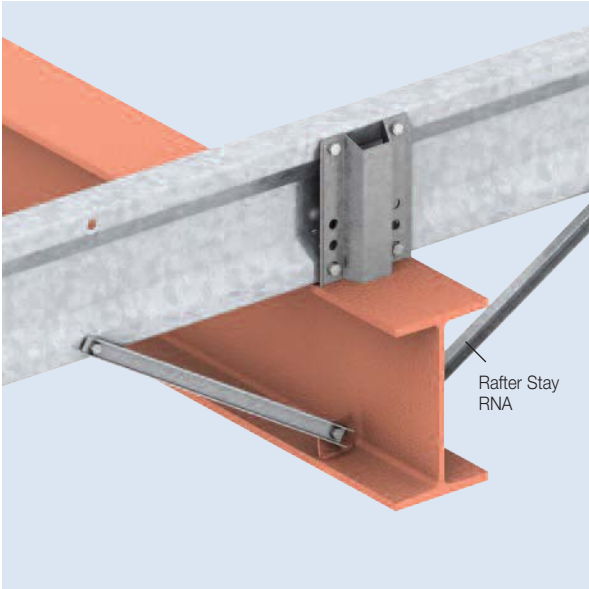

For product dimensions refer to page 30.

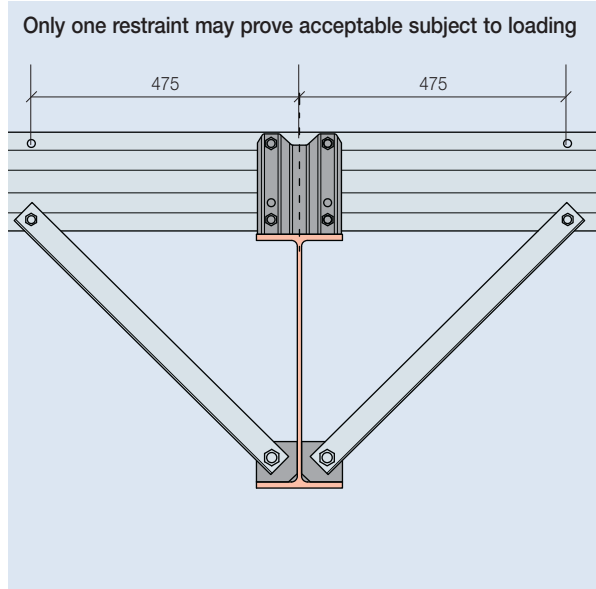

Rafter Stay type RNB

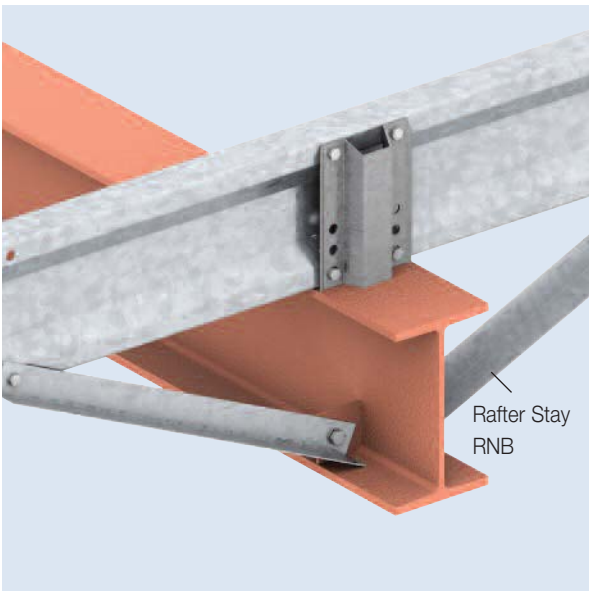

For product dimensions refer to page 30.

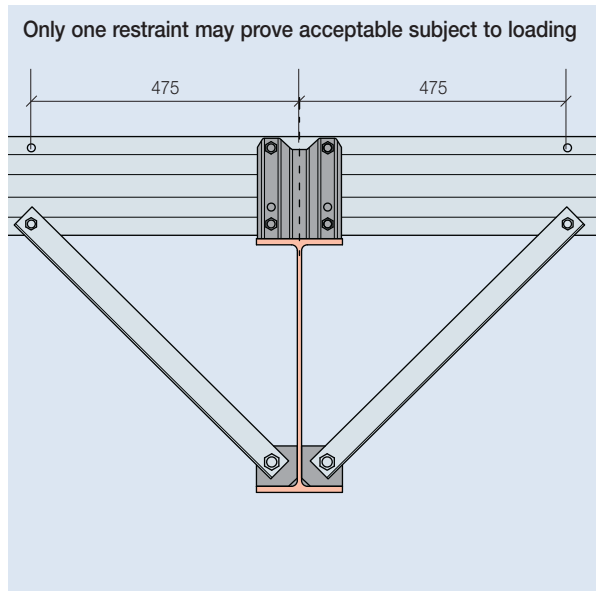

Construction Details - Purlin System

Flat Roof, Shallow Pitch Purlin Arrangement - 3° or less

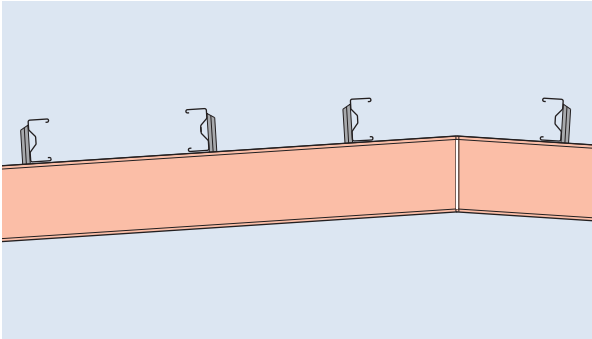
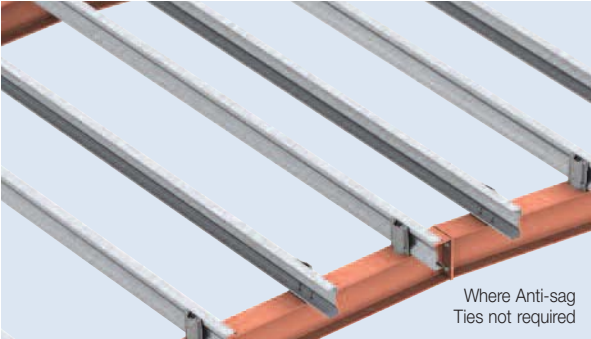

For product dimensions refer to page 24.

Flat Roof Purlin Arrangement

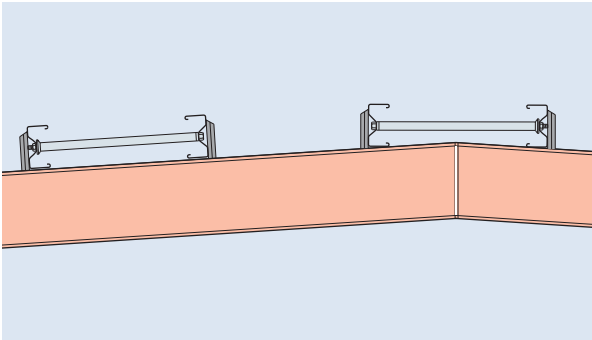

For product dimensions refer to page 24 and 29.

Heavy Duty Flat Roof Restraint

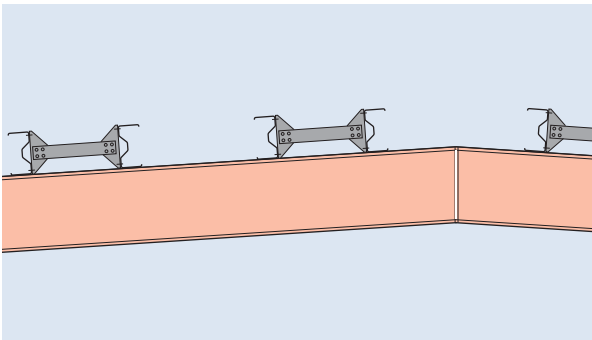
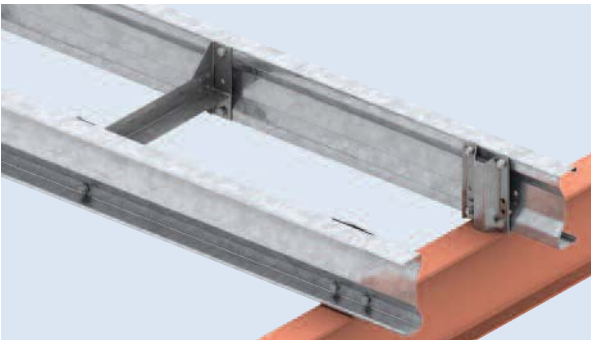

Multilok tie for M145 section

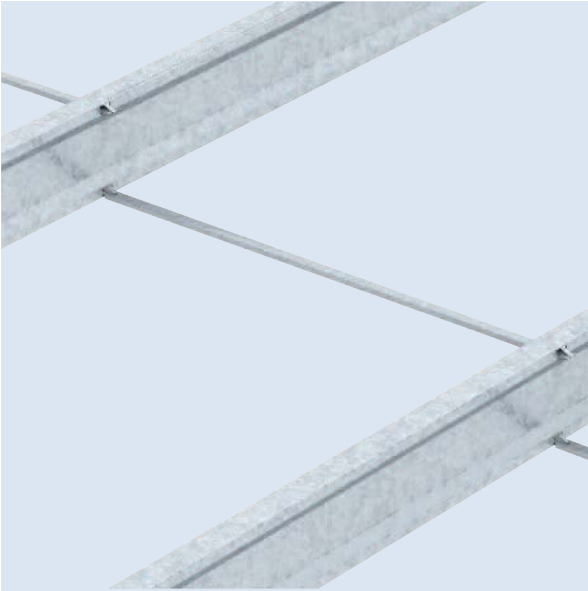

For product dimensions refer to page 29.

Multilok tie for M175 and M205 sections

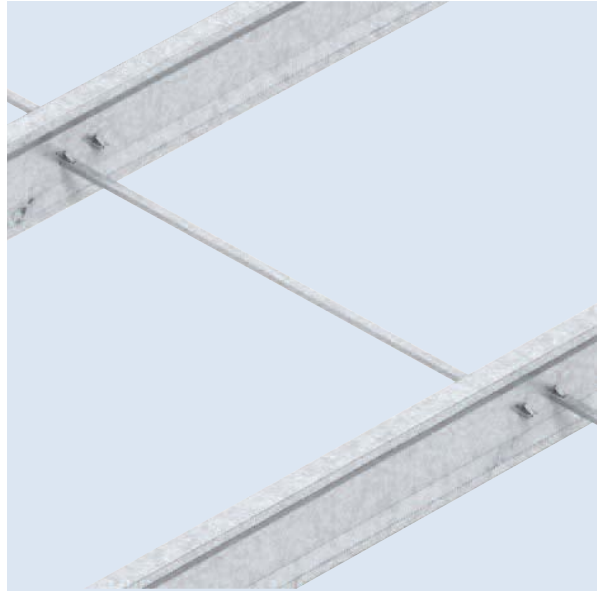

Tubular Tie

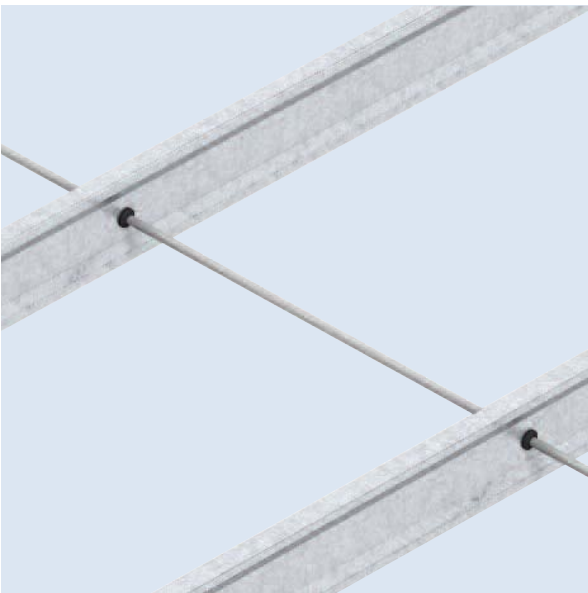

For product dimensions refer to page 29.

Tubular Tie termination of restraint

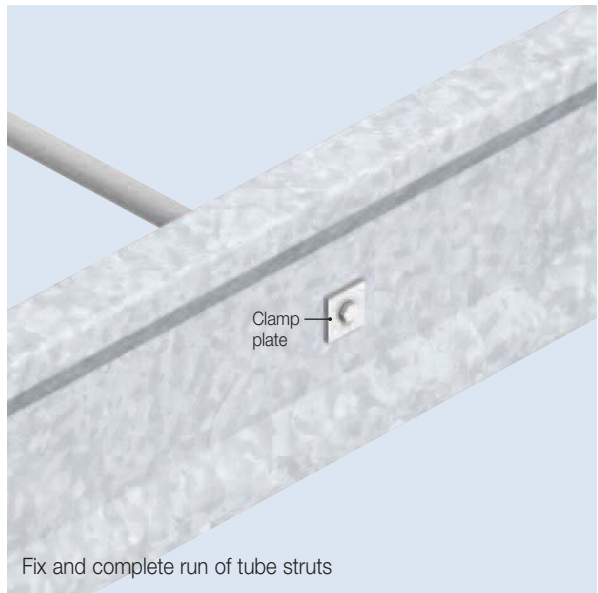

Construction Details - Purlin System

Tiled Roofs

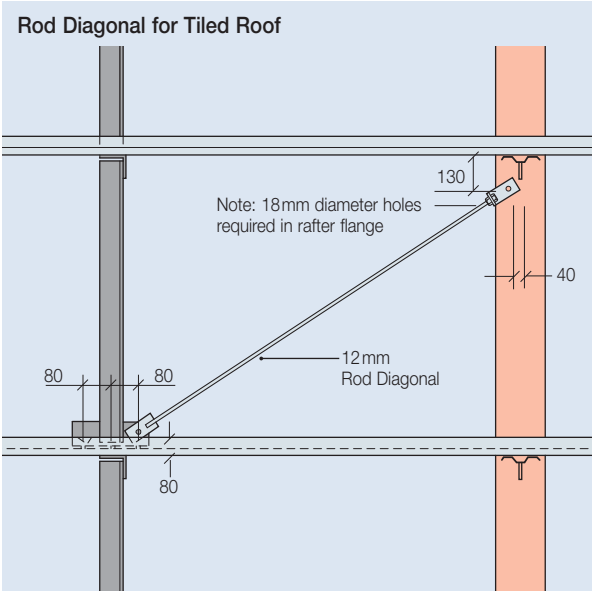
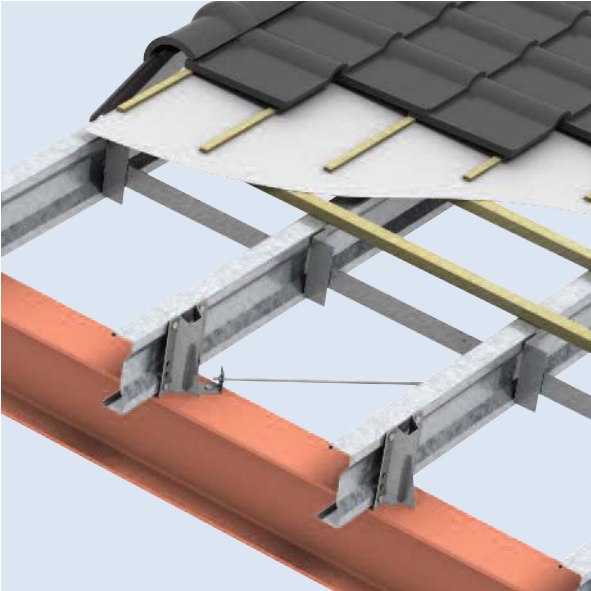

For product dimensions refer to page 31.
For system layout see page 14.

Tiled Roof System Layout

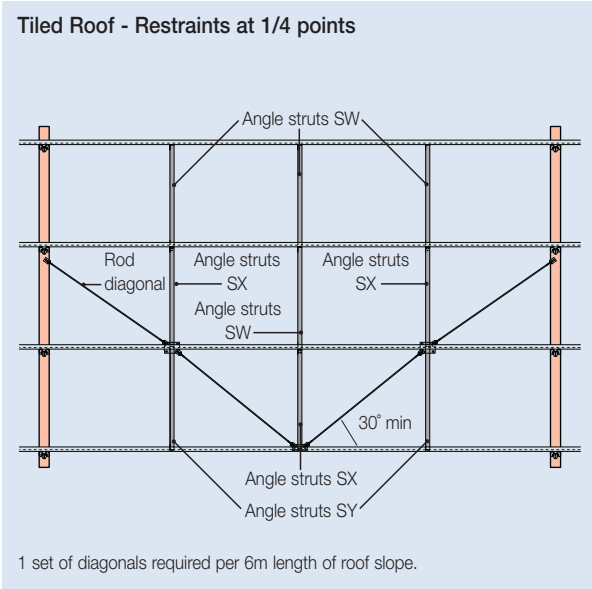
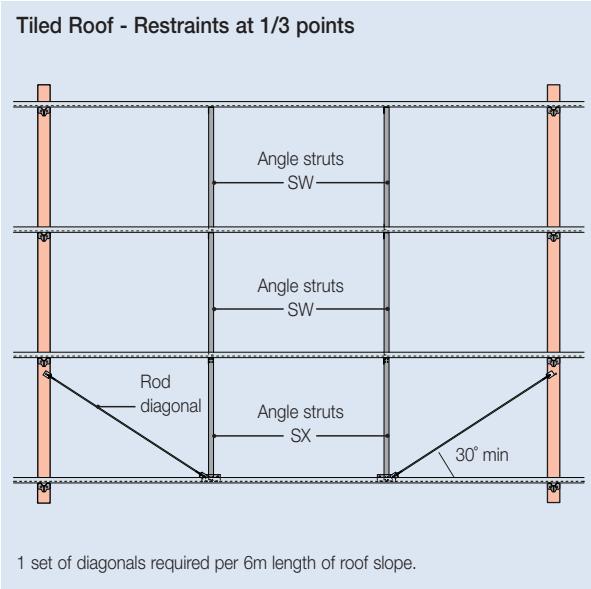

For product dimensions refer to page 31.

Diagonal Tie Wire - Roof

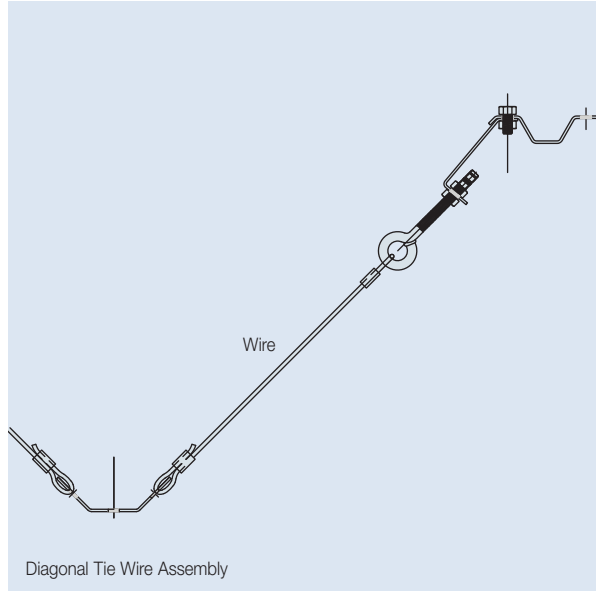
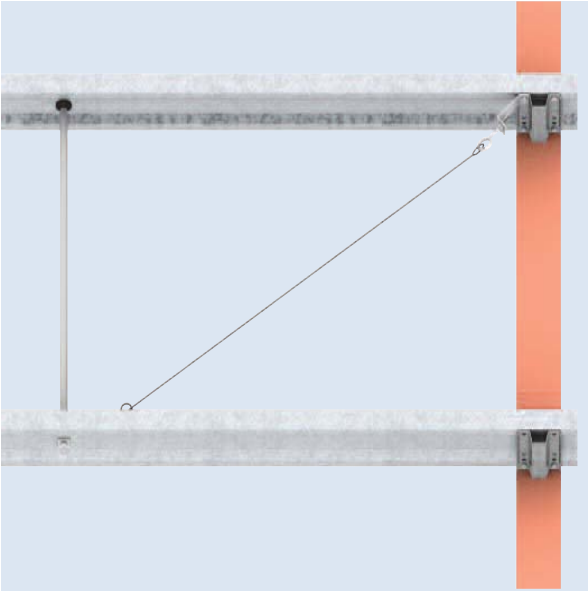

For product dimensions refer to page 31.

Apex Restraint

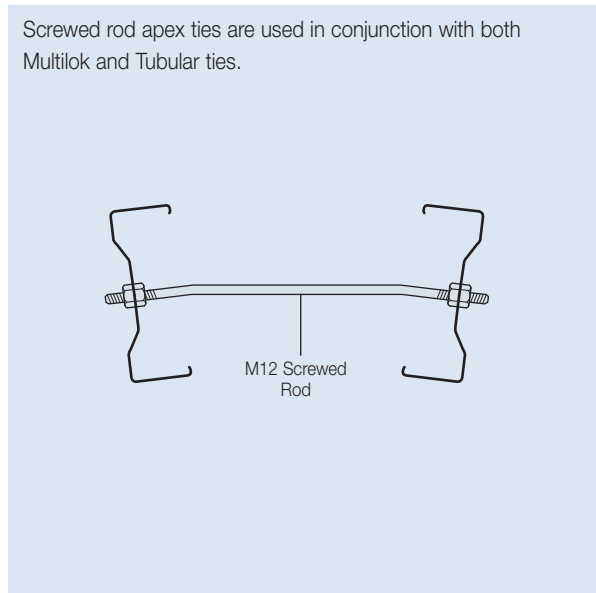
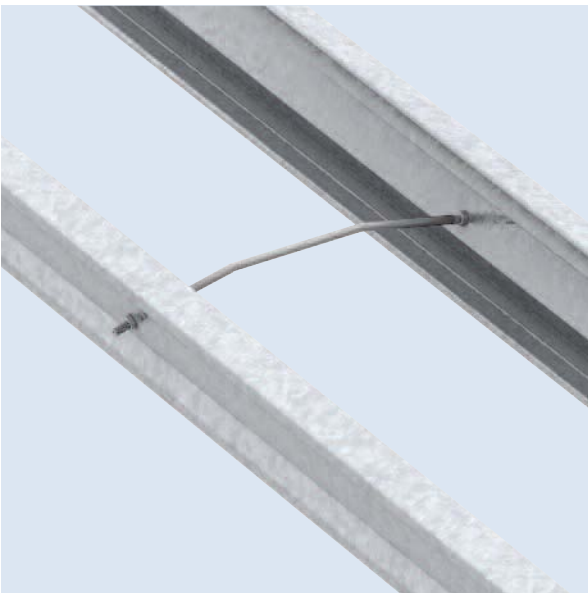

Screwed rod apex ties are used in conjunction with both Multilok and Tubular ties.

For product dimensions refer to page 29.

Product Dimensions and References

Multibeam Purlins

Table 1:6 Multibeam Purlin Product Dimensions and References

References	Weight Kg/m	A	Dims (mm)			Gauge (mm)
			B	C	D	
M145065120	2.75	145	65	8	20	1.20
M145065130	2.99	145	65	8	20	1.30
M145065140	3.21	145	65	8	20	1.40
M145065150	3.45	145	65	8	20	1.50
M145065160	3.69	145	65	8	20	1.60
M145065180	4.15	145	65	8	20	1.80
M145065200	4.63	145	65	8	20	2.00
M145065220	5.06	145	65	8	20	2.20
M175065120	3.02	175	65	38	20	1.20
M175065130	3.29	175	65	38	20	1.30
M175065140	3.52	175	65	38	20	1.40
M175065150	3.79	175	65	38	20	1.50
M175065160	4.05	175	65	38	20	1.60
M175065180	4.55	175	65	38	20	1.80
M175065200	5.08	175	65	38	20	2.00
M175065220	5.56	175	65	38	20	2.20
M175065250	6.35	175	65	38	20	2.50
M205065120	3.29	205	65	68	20	1.20
M205065130	3.58	205	65	68	20	1.30
M205065140	3.84	205	65	68	20	1.40
M205065150	4.13	205	65	68	20	1.50
M205065160	4.41	205	65	68	20	1.60
M205065170	4.67	205	65	68	20	1.70
M205065180	4.96	205	65	68	20	1.80
M205065200	5.53	205	65	68	20	2.00
M205065220	6.05	205	65	68	20	2.20
M205065250	6.91	205	65	68	20	2.50
M205065270	7.49	205	65	68	20	2.70

References	Weight Kg/m	A	Dims (mm)			Gauge (mm)
			B	C	D	
M235065130	3.86	235	65	98	20	1.30
M235065140	4.14	235	65	98	20	1.40
M235065150	4.45	235	65	98	20	1.50
M235065160	4.76	235	65	98	20	1.60
M235065170	5.04	235	65	98	20	1.70
M235065180	5.35	235	65	98	20	1.80
M235065200	5.97	235	65	98	20	2.00
M235065220	6.53	235	65	98	20	2.20
M235065250	7.46	235	65	98	20	2.50
M235065270	8.08	235	65	98	20	2.70
M265065140	4.46	265	65	128	20	1.40
M265065150	4.79	265	65	128	20	1.50
M265065160	5.13	265	65	128	20	1.60
M265065180	5.76	265	65	128	20	1.80
M265065200	6.43	265	65	128	20	2.00
M265065220	7.03	265	65	128	20	2.20
M265065250	8.03	265	65	128	20	2.50
M265065270	8.70	265	65	128	20	2.70
M300090150	5.86	300	90	94	40	1.50
M300090160	6.27	300	90	94	40	1.60
M300090180	7.05	300	90	94	40	1.80
M300090200	7.86	300	90	94	40	2.00
M300090250	9.82	300	90	94	40	2.50
M300090270	10.64	300	90	94	40	2.70
M350090150	6.43	350	90	144	40	1.50
M350090160	6.87	350	90	144	40	1.60
M350090180	7.72	350	90	144	40	1.80
M350090200	8.62	350	90	144	40	2.00
M350090250	10.77	350	90	144	40	2.50
M350090270	11.66	350	90	144	40	2.70

Reference Key

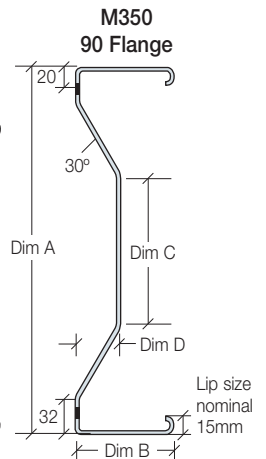
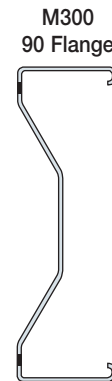
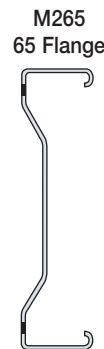
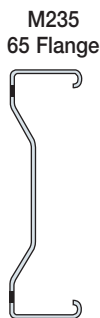
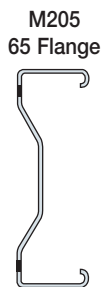
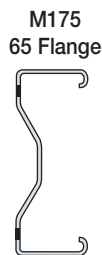
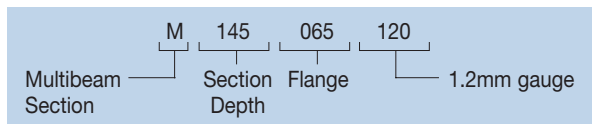

Gauges	Gauges	Gauges	Gauges	Gauges	Gauges	Gauges
1.2	1.2	1.2	-	-	-	-
1.3	1.3	1.3	1.3	-	-	-
1.4	1.4	1.4	1.4	1.4	-	-
1.5	1.5	1.5	1.5	1.5	1.5	1.5
1.6	1.6	1.6	1.6	1.6	1.6	1.6
-	-	1.7	1.7	-	-	-
1.8	1.8	1.8	1.8	1.8	1.8	1.8
2.0	2.0	2.0	2.0	2.0	2.0	2.0
2.2	2.2	2.2	2.2	2.2	-	-
-	2.5	2.5	2.5	2.5	2.5	2.5
-	-	2.7	2.7	2.7	2.7	2.7

Multicleats

All multicleat holes shown are 14mm diameter.

Multicleats provide the most economical solution for stooled off purlins.

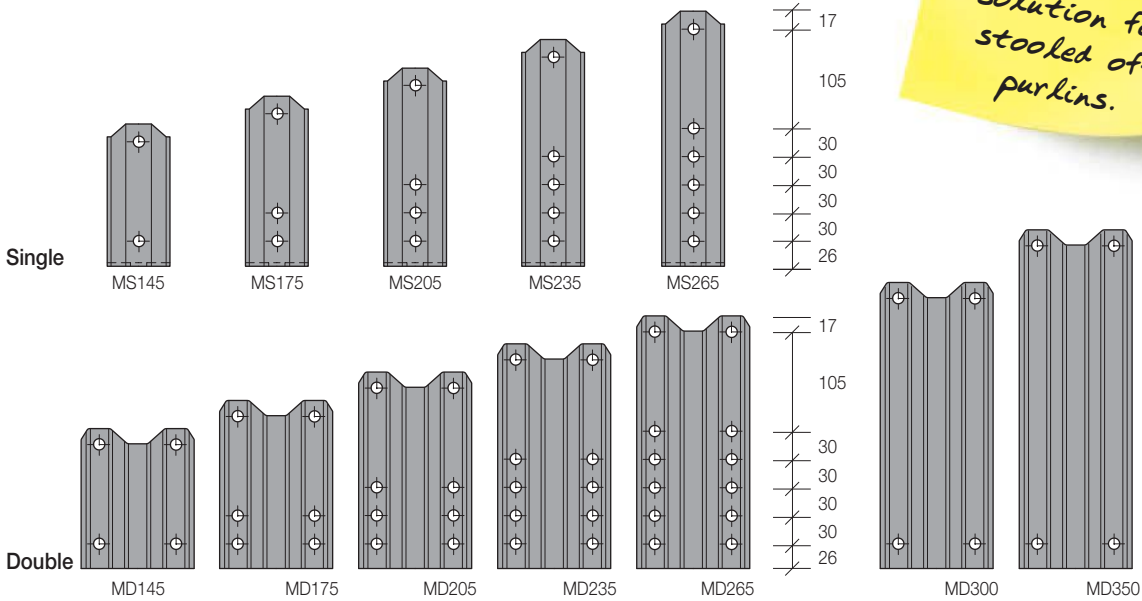

Table 1:7 Multicleat References

Sheeting Line (mm)	Multibeam Section Depths (mm)	Cleat Type			
		Weld-On		Bolt-On	
		Double	Single	Double	Single
151	145	MD 145	MS145	MD 145BB	MS 145BB
181	up to 175	MD 175	MS 175	MD 175BB	MS 175BB
211	up to 205	MD 205	MS 205	MD 205BB	MS 205BB
241	up to 235	MD 235	MS 235	MD 235BB	MS 235BB
271	up to 265	MD 265	MS 265	MD 265BB	MS 265BB
306	300	MD 300	MS 300	MD 300BB	MS 300BB
356	350	MD 350	MS 350	MD 350BB	MS 350BB

*All Cleats are supplied in unpainted steel as standard. Painted or galvanised finishes are available if required. Please note, for galvanised finish there is an extended lead time, please contact our Sales Department for more information.

Standard Single Cleat

Standard Double Cleat

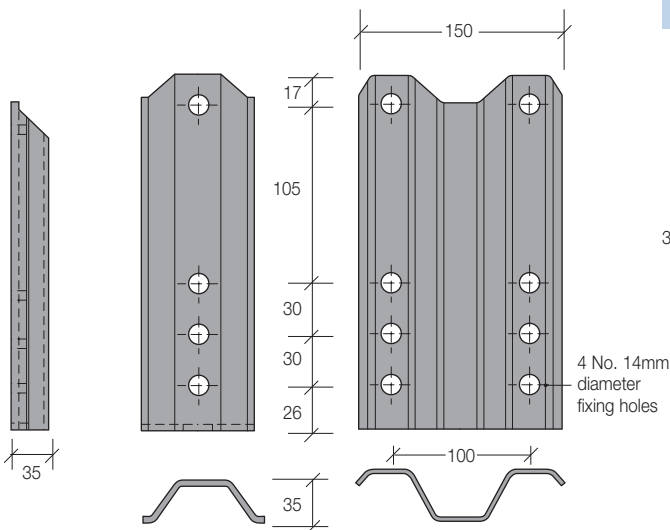

Table 1:8 Multicleat Options

Options	Suffix	Example
Bolt-on Black	BB	MD175BB
Bolt-on Painted	BE	MD175BE
Bolt-on Galvanised	BG	MD175BG
Stiffened	S	MD265BS
Extended	X	MD265X300 (ie; 300mm from rafter face)

300/350 deep are supplied stiffened, see page 27 for details.

Product Dimensions and References

Bolt-on Purlin Multicleats

All Multicleats are available as bolt-on.
See table 1:8 on page 25.

Table 1:9 Base plate thicknesses

Multicleat Depth	Multicleat Base Plate Thickness (mm)
145	6
175	6
205	8
235	8
265	8
300	8
350	8

Table 1:10 Base plate holes cross centres

Base Plate Holes Cross Centres*	Dim H (mm)
50	55
60	55
70 (standard)	50
80	50
90	50
100	50

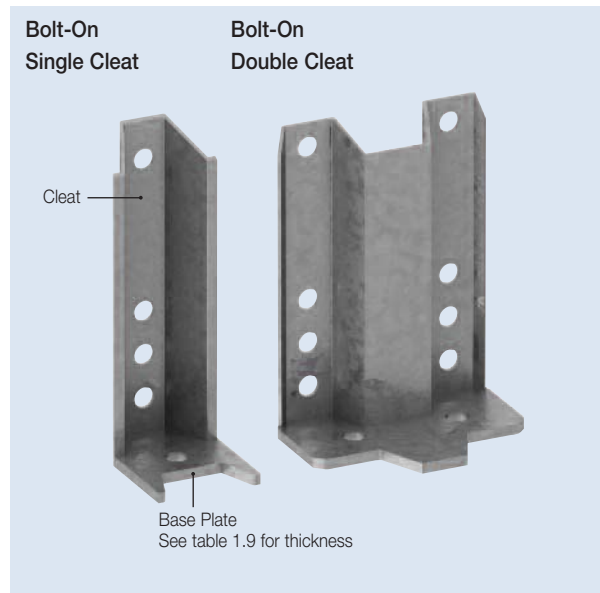

Multicleats allow differing section sizes to be used on any elevation, while maintaining a constant sheeting line.

Bolt-On Single Cleat

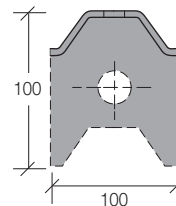

Bolt-On Double Cleat

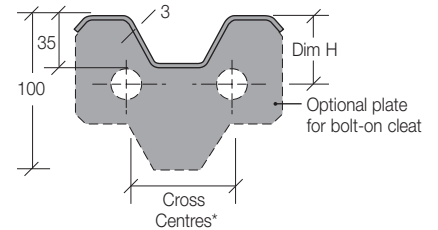

All holes are 18 diameter

NOTE: All dimensions are in mm unless otherwise stated

Standard Single Cleat

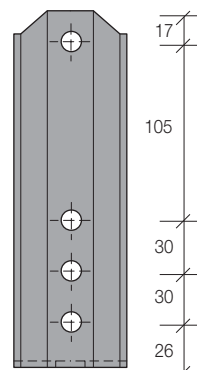

Standard Double Cleat

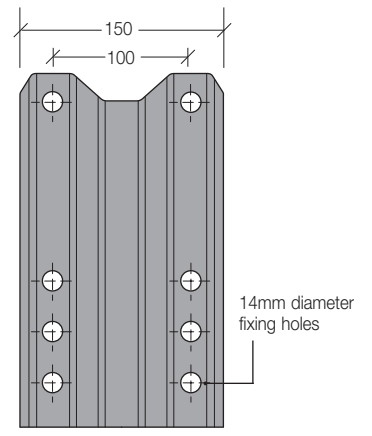



Stiffened Purlin Multicleats

All Multicleats are available with stiffeners where required, eg. tiled roof applications. Add 'stiffened' to Multicleat reference when ordering.

Extended Purlin Cleats

Extended cleats can be manufactured to meet your specific requirements. These are manufactured to order and will be at an additional cost.

NB: Add 'extended' to cleat reference when ordering.

Extended **double** cleats over 270mm long are supplied complete with stiffeners. **These are not available with single cleats.**

Multicleat Arrangement

Multicleats allow differing section sizes to be used on any elevation, while maintaining a constant sheeting line.

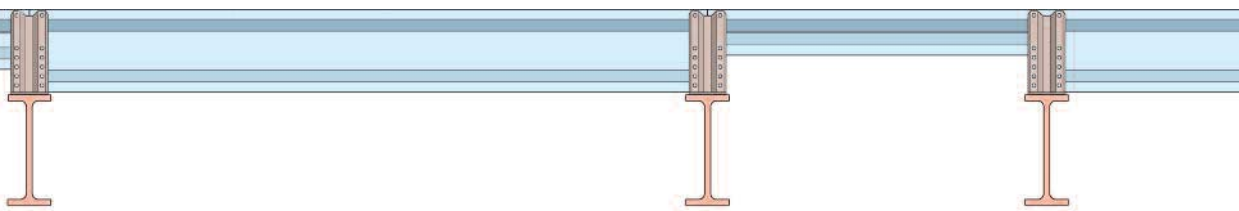
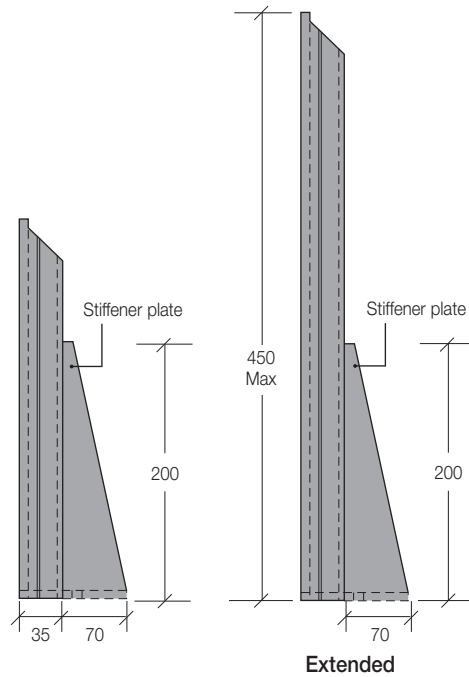
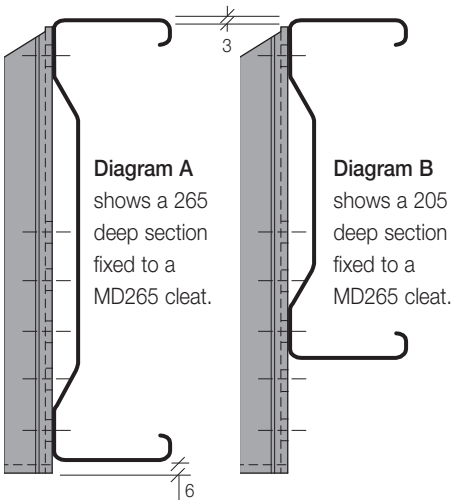

Product Dimensions and References

Purlin Sleeves

Used to provide continuity at a purlin joint normally at a single span to a double, or a single to a single span, or at all joints in heavy end bay layout.

Please specify sleeve reference as below.

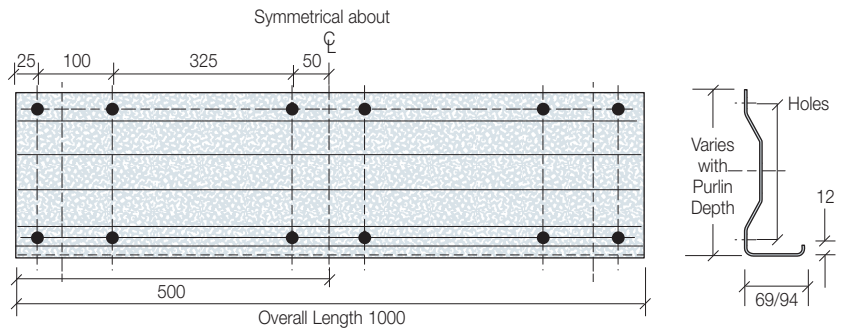

For application details see page 9. For construction details see page 17.

All holes are 14mm Dia unless noted.

Table 1:11
Multibeam Sleeve Product References

Multibeam Part Reference	Sleeve Part Reference	Nominal Sleeve Gauge (mm)	Multibeam Part Reference	Sleeve Part Reference	Nominal Sleeve Gauge (mm)				
M145065120	S145065A	1.6	M235065130	S235065A	1.6				
M145065130			M235065140						
M145065140			M235065150						
M145065150			M235065160						
M145065160	S145065B	2.0	M235065170	S235065B	2.0				
M145065180			M235065180						
M145065200			M235065200						
M145065220			M235065220						
M145065250	S145065C	3.0	M235065250	S235065C	3.0				
M175065120			M235065270						
M175065130			S175065A			1.6	M265065140	S265065A	1.6
M175065140							M265065150		
M175065150	M265065160								
M175065160	M265065180								
M175065180	S175065B	2.0	M265065200	S265065B	2.0				
M175065200			M265065220						
M175065220			M265065250						
M175065250			M265065270						
M175065270	S175065C	3.0	M300090150	S300090A	1.6				
M205065120			M300090160						
M205065130			M300090180						
M205065140			M300090200						
M205065150	S205065A	1.6	M300090250	S300090B	2.0				
M205065160			M300090270						
M205065170			S205065B			2.0	M350090150	S350090A	1.6
M205065180							M350090160		
M205065200	M350090180								
M205065220	M350090200								
M205065250	S205065C	3.0	M350090250	S350090B	2.0				
M205065270			M350090270						
			M350090250						
			M350090270						

Sleeve Reference Key

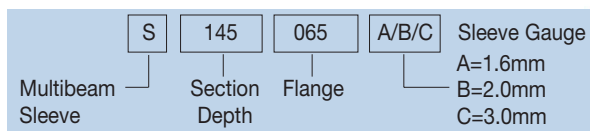

MULTIBEAM EVOLVED

“ Wider range of sleeves for a more economic solution ”

Tube Strut TSA

Used to restrain purlins (exc. M145).

Part Reference
 TSA0000
 where 0000 = Purlin Centres
 eg; TSA1000 (Purlin Centres = 1000mm)
 Minimum length 150mm
 For design details see page 11. For construction details see page 21.

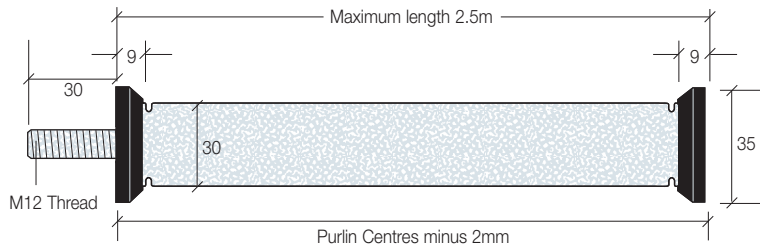

Tube Strut TS14

Used to restrain M145 purlins

Part Reference
 TS140000
 where 0000 = Purlin Centres
 eg; TS141000 (Purlin Centres = 1000mm)
 Minimum length 150mm
 For design details see page 11. For construction details see page 21.

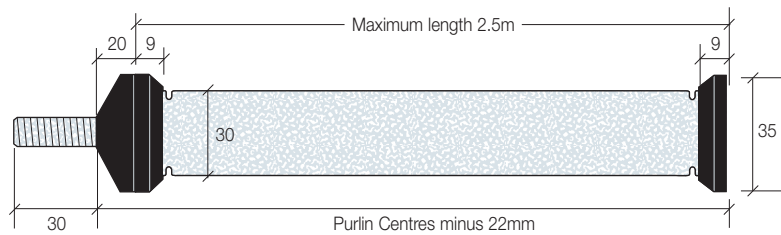

Clamp Plates

Used to fix and complete a run of tube struts, CA145 used with M145 purlins

Part Reference
 CA145 CA
 For construction details see page 21.

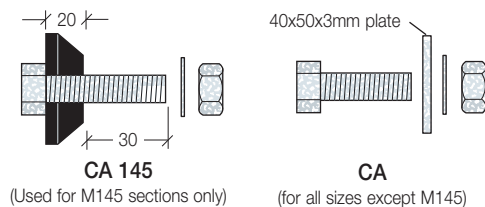

Multilok Ties

Used to restrain purlins

Part Reference
 TM0000
 where 0000 = Purlin Centres
 eg; TM1600 (Purlin Centres = 1600mm)
 For design details see page 11. For construction details see page 21.

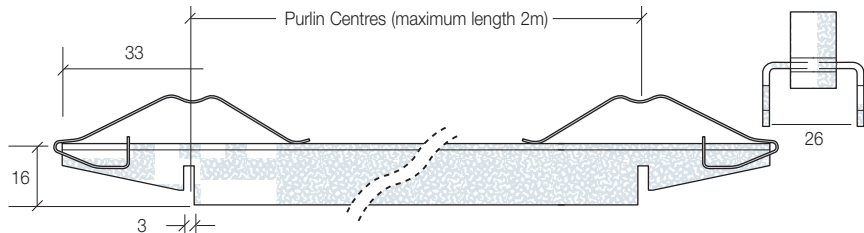

Apex Ties

Used to tie the apex purlins together on duo pitch roofs

Part Reference
 AT0000/XX
 where 0000 = length between bends and XX
 is roof slope eg; AT0250/15
 eg. Ridge to purlin 250mm, Roof Slope 15°
 For construction details see page 23.

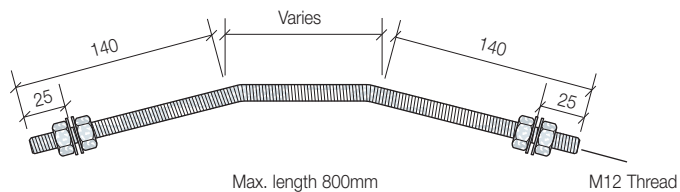

Heavy Duty Flat Roof Restraint SWF

Angle strut used to restrain the larger sections on flat roof applications

Part Reference
 SWF0000
 where 0000 = overall length eg; SWF1500
 (overall length = 1500mm)
 Purlin section size must be specified
 For construction details see page 20.

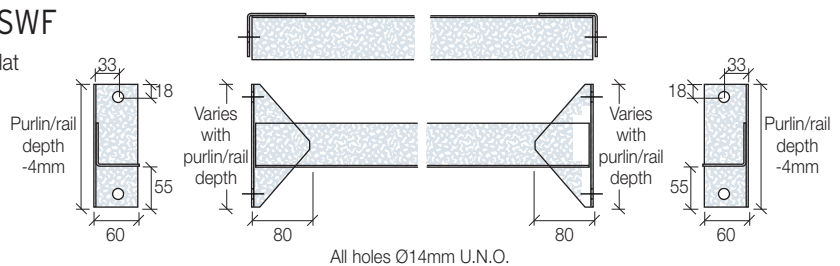

Product Dimensions and References

Tiled Roof Struts/Angle Struts

Angle strut used to restrain the larger sections on longer spans and as the primary restraint member for the support of tiled roofs

Part Reference

SW0000

where 0000 = Purlin Centres

eg; SW1500 (Purlin Centres = 1500mm)

Purlin section size must be specified.

For design details see page 14. For construction details see page 22.

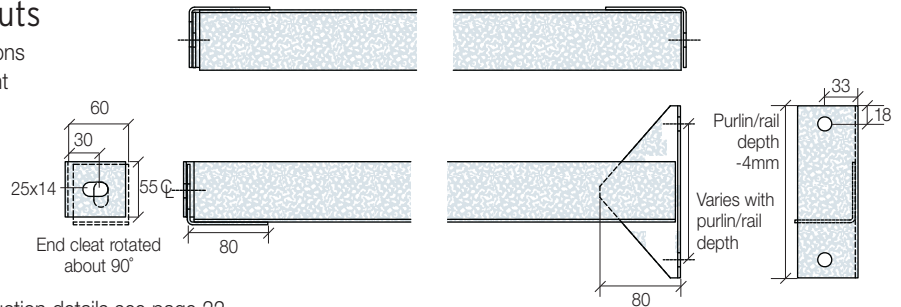

Tiled Roof Struts/Angle Struts

Angle strut used to terminate a run of SW struts at mid span and provide the attachment of the screwed rod diagonal

Part Reference

SX0000

where 0000 = Purlin Centres

eg; SX1500 (Purlin Centres = 1500mm)

Purlin section size must be specified.

For design details see page 14. For construction details see page 22.

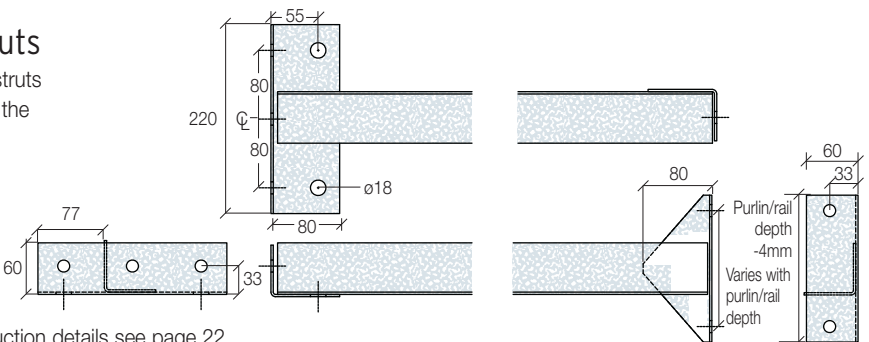

Tiled Roof Struts/Angle Struts

Angle strut used to terminate a run of SW struts at the 1/4 point position

Part Reference

SY0000

where 0000 = Purlin Centres

eg; SY1500 (Purlin Centres = 1500mm)

Purlin section size must be specified.

For design details see page 14.

For construction details see page 22.

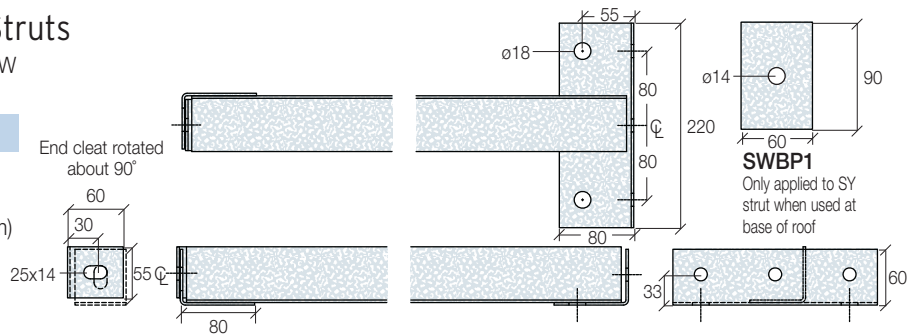

Rafter Restraint RNA

Channel stay to provide compression and tension restraint from the purlin to the inner flange of the main frame

Part Reference

RNA0000

where 0000 = Length between Hole Centres

eg; RNA1000 (Hole Centres = 1000mm)

For construction details see page 19.

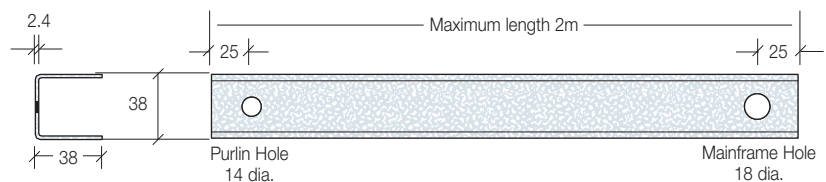

Rafter Restraint RNB

Angle stay to provide compression and tension restraint from the purlin to the inner flange of the main frame suitable for smaller main frame sections

Part Reference

RNB0000

where 0000 = Length between Hole Centres

eg; RNB1000 (Hole Centres = 1000mm)

For construction details see page 19.

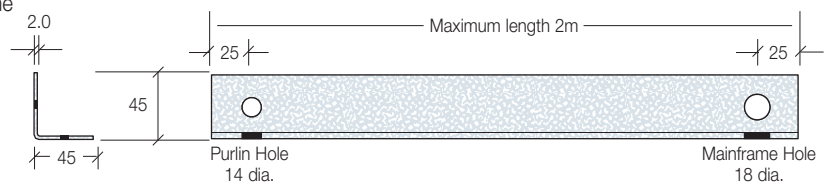

Diagonal Tie Wire

Used on some long purlin slopes to support the self weight of the cladding and transfer it to the rafters

Part Reference

- DB
- DA

Please state your dimension 'X' and 'Y'

For design details see page 15. For construction details see page 23.

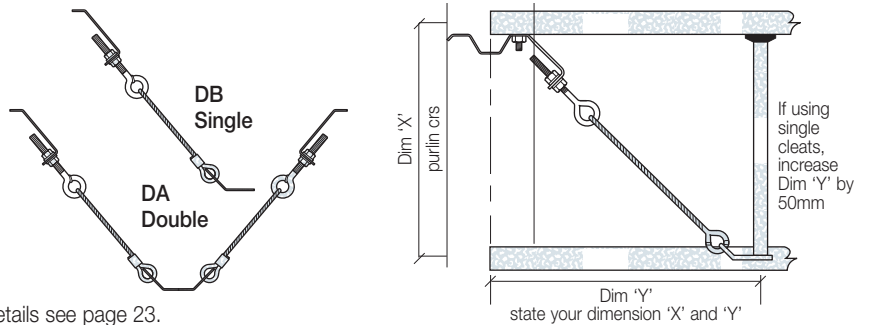

Multibracket

Multibrackets are used to make connections between Multichannels and Multibeam

Part Reference

- MB1A (Left hand) as shown
- MB1B (Right hand)

Material 3.0mm galvanised steel.
All holes 14 diameter.

For design details see pages 68-69. For construction details see page 74.

Note: Multibrackets are not suitable for connecting sections to a 90mm flange.

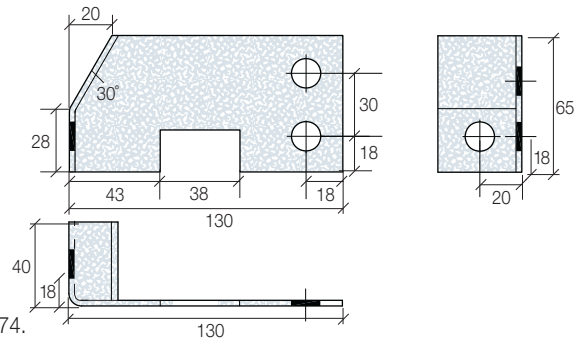

Cleider Angles

Cleider angles are used to provide a cladding attachment at the ends of the purlin overhang.

Part Reference

- | Part Reference | Part Reference |
|----------------|----------------|
| AC | C135V270 |
| AR | |

Standard 4m lengths. Supplied in standard finish galvanised steel. Plain lengths (i.e. no holes).

Supplied in standard finish galvanised steel. Custom made Max length 8m Please specify hole position along the length. Hole = 18mm diameter.

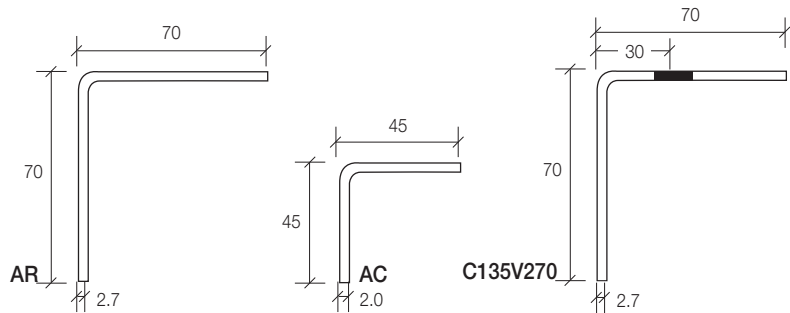

For construction details see page 18.

Rod Diagonals

The diagonal used with the purlins supporting tiled roofs to transfer the down slope load to the main frame

Part Reference

- TRSP0000
where 0000 = Length between Hole Centres
eg: TRSP1000
(Hole Centres = 1000mm)

For design details see page 14.
For construction details see page 22.

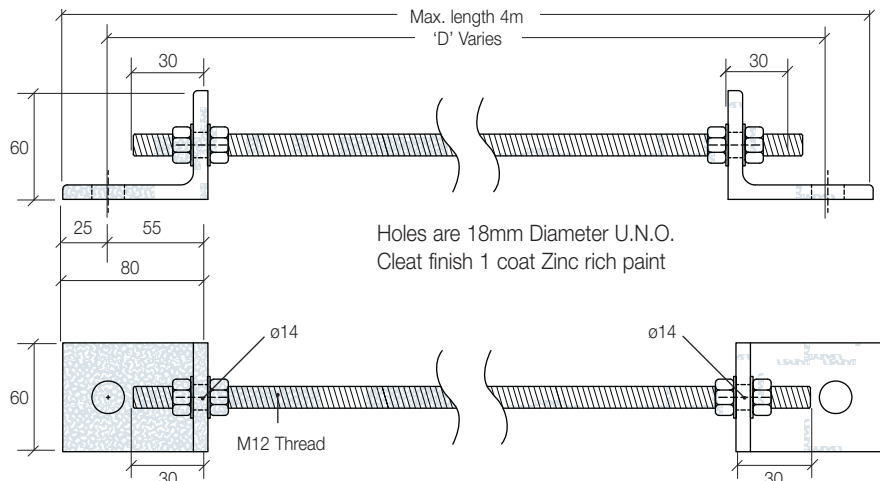

Multibeam Purlins - Section Properties

Table 1:12 Multibeam section properties

Section	Thickness mm	Area cm ²	Weight kg/m	Ixx cm ⁴	Gross Zxx cm ³	Iyy cm ⁴	Zyy cm ³	Rxx cm	Ryy cm
M145065120	1.20	3.68	2.75	121.15	16.72	19.24	4.56	5.74	2.29
M145065130	1.30	3.99	2.99	131.11	18.09	20.74	4.91	5.73	2.28
M145065140	1.40	4.30	3.21	140.99	19.45	22.21	5.26	5.73	2.27
M145065150	1.50	4.60	3.45	150.77	20.80	23.66	5.60	5.72	2.27
M145065160	1.60	4.91	3.69	160.48	22.14	25.08	5.94	5.72	2.26
M145065180	1.80	5.51	4.15	179.69	24.79	27.86	6.60	5.71	2.25
M145065200	2.00	6.11	4.63	198.62	27.40	30.54	7.23	5.70	2.24
M145065220	2.20	6.71	5.06	217.21	29.97	33.12	7.84	5.69	2.22
M175065120	1.20	4.03	3.02	187.92	21.48	19.28	4.53	6.83	2.19
M175065130	1.30	4.37	3.29	203.42	23.25	20.79	4.89	6.82	2.18
M175065140	1.40	4.71	3.52	218.82	25.01	22.26	5.23	6.82	2.17
M175065150	1.50	5.04	3.79	234.07	26.76	23.71	5.57	6.81	2.17
M175065160	1.60	5.38	4.05	249.21	28.49	25.13	5.91	6.81	2.16
M175065180	1.80	6.04	4.55	279.21	31.92	27.91	6.56	6.80	2.15
M175065200	2.00	6.70	5.08	308.79	35.30	30.60	7.19	6.79	2.14
M175065220	2.20	7.36	5.56	337.89	38.62	33.18	7.80	6.78	2.12
M175065250	2.50	8.33	6.35	380.74	43.52	36.89	8.68	6.76	2.10
M205065120	1.20	4.38	3.29	272.82	26.62	19.32	4.51	7.89	2.10
M205065130	1.30	4.75	3.58	295.39	28.83	20.83	4.86	7.89	2.09
M205065140	1.40	5.11	3.84	317.82	31.01	22.30	5.21	7.88	2.09
M205065150	1.50	5.48	4.13	340.05	33.18	23.75	5.55	7.88	2.08
M205065160	1.60	5.84	4.41	362.13	35.34	25.18	5.88	7.87	2.08
M205065170	1.70	6.21	4.67	384.50	37.52	26.63	6.22	7.87	2.07
M205065180	1.80	6.57	4.96	405.91	39.61	27.96	6.54	7.86	2.06
M205065200	2.00	7.29	5.53	449.12	43.82	30.64	7.17	7.85	2.05
M205065220	2.20	8.00	6.05	491.68	47.98	33.23	7.77	7.84	2.04
M205065250	2.50	9.06	6.91	554.41	54.10	36.94	8.64	7.82	2.02
M205065270	2.70	9.76	7.49	595.41	58.10	39.29	9.20	7.81	2.01
M235065130	1.30	5.12	3.86	408.72	34.79	20.86	4.85	8.93	2.02
M235065140	1.40	5.52	4.14	439.84	37.44	22.34	5.19	8.92	2.01
M235065150	1.50	5.92	4.45	470.70	40.07	23.79	5.53	8.92	2.01
M235065160	1.60	6.31	4.76	501.35	42.68	25.21	5.86	8.91	2.00
M235065170	1.70	6.70	5.04	531.67	45.26	26.59	6.18	8.91	1.99
M235065180	1.80	7.10	5.35	562.18	47.85	28.00	6.51	8.90	1.99
M235065200	2.00	7.88	5.97	622.25	52.97	30.69	7.14	8.89	1.97
M235065220	2.20	8.65	6.53	681.48	58.01	33.27	7.75	8.88	1.96
M235065250	2.50	9.80	7.46	768.88	65.45	36.98	8.62	8.86	1.94
M235065270	2.70	10.56	8.08	826.07	70.32	39.33	9.17	8.84	1.93
M265065140	1.40	5.93	4.46	586.70	44.29	22.37	5.17	9.95	1.94
M265065150	1.50	6.36	4.79	627.97	47.40	23.82	5.51	9.94	1.94
M265065160	1.60	6.78	5.13	668.97	50.50	25.25	5.84	9.93	1.93
M265065180	1.80	7.63	5.76	750.38	56.64	28.04	6.49	9.92	1.92
M265065200	2.00	8.47	6.43	830.83	62.71	30.72	7.12	9.91	1.91
M265065220	2.20	9.30	7.03	910.21	68.71	33.31	7.72	9.89	1.89
M265065250	2.50	10.54	8.03	1027.46	77.56	37.01	8.59	9.87	1.87
M265065270	2.70	11.36	8.70	1104.27	83.36	39.36	9.14	9.86	1.86
M300090150	1.50	7.75	5.86	1017.30	67.83	54.24	9.60	11.45	2.64
M300090160	1.60	8.27	6.27	1084.30	72.30	57.60	10.20	11.45	2.64
M300090180	1.80	9.31	7.05	1217.51	81.18	64.22	11.37	11.44	2.63
M300090200	2.00	10.34	7.86	1349.43	89.97	70.67	12.52	11.42	2.61
M300090250	2.50	12.89	9.82	1673.13	111.56	86.07	15.27	11.39	2.58
M300090270	2.70	13.91	10.64	1800.32	120.04	91.94	16.32	11.38	2.57
M350090150	1.50	8.48	6.43	1470.17	84.02	54.45	9.72	13.16	2.53
M350090160	1.60	9.05	6.87	1567.25	89.57	57.83	10.33	13.16	2.53
M350090180	1.80	10.19	7.72	1760.37	100.61	64.50	11.52	13.14	2.52
M350090200	2.00	11.32	8.62	1951.76	111.54	70.99	12.69	13.13	2.50
M350090250	2.50	14.12	10.77	2422.01	138.42	86.50	15.49	13.09	2.47
M350090270	2.70	15.24	11.66	2607.02	148.99	92.42	16.57	13.08	2.46

Clearder Angle section properties

Section	Mass Kg/m	Area cm ²	Ixx/Iyy cm ⁴	Ivv cm ⁴	Iuu cm ⁴	Zxx/Zyy cm ³	Zvv cm ²	Zuu cm ²	Rxx/Ryy cm	Rvv cm	Ruu cm
AR (70x70)	3.02	3.84	18.83	7.53	30.13	3.56	2.94	6.04	2.21	1.40	2.80
AC (45x45)	1.33	1.70	3.44	1.38	5.90	1.02	0.84	1.80	1.42	0.88	1.81

Multibeam Purlins - Load Tables



Purlin Ultimate Loads

The load tables show the ultimate load for double span sections in terms of a UDL per span.

Section self weight has not been subtracted in the loads shown. Loadings have also been tabulated that will produce the noted deflection ratio. Loads shown assume lateral restraint to the top flange of the section and that the beams are fixed exactly as indicated in the Multibeam Handbook.

Interpolation of the ultimate loads shown is permissible on a linear basis. Use grade 8.8 bolts for M265, M300 and M350.

For Rafter and Stanchion Stays please refer to page 127.

Loading	Load Factor
Dead load	1.4
Dead load restraining uplift or overturning	1.0
Dead load acting with wind and imposed loads combined	1.2
Imposed load	1.6
Imposed load acting with wind load	1.2
Wind load	1.4
Wind load acting with wind and imposed load	1.2
Forces due to temperature effects	1.2

Table 1:13 Double span and single span sleeved

Span (m)	Section	Weight kg/m	Ultimate UDL Gravity kN	Ultimate UDL Suction kN	Load to Produce Deflection L/180 kN
4.5	M145065120	2.75	11.95	9.33	-
	M145065130	2.99	14.04	11.23	13.64
	M145065140	3.21	16.21	12.96	14.67
	M145065150	3.45	18.40	14.72	15.69
	M145065160	3.69	20.61	16.49	16.70
	M145065180	4.15	24.96	19.97	18.70
	M145065200	4.63	29.10	23.28	20.67
	M145065220	5.06	33.02	26.42	22.60
	M175065120	3.02	14.66	11.73	-
	M175065130	3.29	17.29	13.83	-
	M175065140	3.52	19.98	15.99	-
	M175065150	3.79	22.45	17.96	-
	M175065160	4.05	24.52	19.61	-
	M175065180	4.55	29.74	23.34	29.05
	M175065200	5.08	34.07	27.25	32.13
	M175065220	5.56	38.74	31.00	35.16
	M175065250	6.35	45.42	36.34	39.62
	M205065120	3.29	16.44	13.02	-
	M205065130	3.58	19.44	14.98	-
	M205065140	3.84	22.53	17.40	-
	M205065150	4.13	25.67	19.89	-
	M205065160	4.41	28.82	22.40	-
	M205065170	4.67	31.97	24.55	-
	M205065180	4.96	35.90	26.47	-
	M205065200	5.53	39.16	30.69	-
	M205065220	6.05	44.66	35.08	-
	M205065250	6.91	52.52	41.37	-
	M205065270	7.49	57.57	45.42	-
	M235065130	3.86	22.89	17.58	-
	M235065140	4.14	26.61	20.35	-
M235065150	4.45	30.38	23.35	-	
M235065160	4.76	34.07	26.73	-	
M235065170	5.04	37.23	28.82	-	
M235065180	5.35	40.75	31.47	-	
M235065200	5.97	46.89	36.54	-	
M235065220	6.53	53.69	44.28	-	
M235065250	7.46	63.30	52.41	-	
5.0	M145065120	2.75	10.94	8.75	10.21
	M145065130	2.99	12.82	10.26	11.05
	M145065140	3.21	14.78	11.82	11.88
	M145065150	3.45	16.76	13.41	12.71
	M145065160	3.69	18.75	15.00	13.53
	M145065180	4.15	22.67	18.13	15.14
	M145065200	4.63	26.39	21.12	16.74

Span (m)	Section	Weight kg/m	Ultimate UDL Gravity kN	Ultimate UDL Suction kN	Load to Produce Deflection L/180 kN
4.5	M145065220	5.06	29.93	23.94	18.31
	M175065120	3.02	13.48	10.79	-
	M175065130	3.29	15.85	12.68	-
	M175065140	3.52	18.28	14.63	-
	M175065150	3.79	20.50	16.40	19.73
	M175065160	4.05	22.36	17.89	21.00
	M175065180	4.55	27.07	21.66	23.53
	M175065200	5.08	30.96	24.76	26.02
	M175065220	5.56	35.16	28.13	28.48
	M175065250	6.35	41.17	32.94	32.09
	M205065120	3.29	15.19	12.15	-
	M205065130	3.58	17.90	14.32	-
	M205065140	3.84	20.69	16.55	-
	M205065150	4.13	23.51	18.81	-
	M205065160	4.41	26.35	21.08	-
	M205065170	4.67	29.19	23.02	-
	M205065180	4.96	30.92	24.74	-
	M205065200	5.53	35.65	28.52	-
	M205065220	6.05	40.60	32.48	-
	M205065250	6.91	47.67	38.13	46.72
	M205065270	7.49	52.21	41.76	50.18
	M235065130	3.86	21.17	16.94	-
	M235065140	4.14	24.53	19.62	-
	M235065150	4.45	27.93	22.34	-
	M235065160	4.76	31.25	25.00	-
	M235065170	5.04	34.09	27.27	-
	M235065180	5.35	37.26	29.65	-
	M235065200	5.97	42.78	34.20	-
	M235065220	6.53	48.89	41.25	-
	M235065250	7.46	57.54	48.54	-
M235065270	8.08	63.13	53.26	-	
5.0	M145065120	2.75	10.08	8.06	8.44
	M145065130	2.99	11.79	9.44	9.13
	M145065140	3.21	13.58	10.86	9.82
	M145065150	3.45	15.38	12.30	10.50
	M145065160	3.69	17.19	13.75	11.18
	M145065180	4.15	20.76	16.60	12.52
	M145065200	4.63	24.15	19.32	13.83
	M145065220	5.06	27.36	21.89	15.13
	M175065120	3.02	12.47	9.97	-
	M175065130	3.29	14.62	11.70	14.17
M175065140	3.52	16.84	13.47	15.24	
M175065150	3.79	18.86	15.09	16.30	
M175065160	4.05	20.55	16.44	17.36	

- indicates the load to produce a deflection of span/180 exceeds ultimate UDL capacity

Multibeam Purlins - Load Tables

Table 1:13 Double span and single span sleeved (Cont.)

Span (m)	Section	Weight kg/m	Ultimate UDL Gravity kN	Ultimate UDL Suction kN	Load to Produce Deflection L/180 kN	Span (m)	Section	Weight kg/m	Ultimate UDL Gravity kN	Ultimate UDL Suction kN	Load to Produce Deflection L/180 kN
	M175065180	4.55	24.83	19.87	19.45		M205065270	7.49	44.00	35.20	34.85
	M175065200	5.08	28.36	22.69	21.51		M235065130	3.86	18.35	14.67	-
	M175065220	5.56	32.19	25.75	23.53		M235065140	4.14	21.15	16.92	-
	M175065250	6.35	37.65	30.12	26.52		M235065150	4.45	24.00	19.20	-
	M205065120	3.29	14.10	11.28	-		M235065160	4.76	26.77	21.42	-
	M205065130	3.58	16.67	13.25	-		M235065170	5.04	29.13	23.30	-
	M205065140	3.84	19.11	15.29	-		M235065180	5.35	31.77	25.42	-
	M205065150	4.13	21.68	17.35	-		M235065200	5.97	36.36	29.07	-
	M205065160	4.41	24.27	19.41	-		M235065220	6.53	41.46	34.97	39.88
	M205065170	4.67	26.85	21.17	26.78		M235065250	7.46	48.65	41.04	45.00
	M205065180	4.96	28.42	22.73	28.27		M235065270	8.08	53.30	44.97	48.35
	M205065200	5.53	32.71	26.17	31.28		M265065140	4.46	23.92	19.12	-
	M205065220	6.05	37.21	29.77	34.25		M265065150	4.79	28.17	22.29	-
	M205065250	6.91	43.63	34.90	38.62		M265065160	5.13	30.45	23.74	-
	M205065270	7.49	47.76	38.20	41.47		M265065180	5.76	37.04	28.00	-
	M235065130	3.86	19.67	15.73	-		M265065200	6.43	42.88	33.11	-
	M235065140	4.14	22.72	18.18	-		M265065220	7.03	48.56	39.15	-
	M235065150	4.45	25.82	20.66	-		M265065250	8.03	58.89	46.22	-
	M235065160	4.76	28.85	23.08	-		M265065270	8.70	64.59	50.80	-
	M235065170	5.04	31.42	25.14	-	6.5	M175065120	3.02	10.82	8.66	9.37
	M235065180	5.35	34.30	27.44	-		M175065130	3.29	12.65	10.12	10.14
	M235065200	5.97	39.31	31.43	-		M175065140	3.52	14.53	11.63	10.91
	M235065220	6.53	44.87	37.86	-		M175065150	3.79	16.25	13.00	11.67
	M235065250	7.46	52.72	44.48	-		M175065160	4.05	17.67	14.13	12.43
	M235065270	8.08	57.80	48.77	57.54		M175065180	4.55	21.30	17.04	13.92
	M265065140	4.46	25.63	20.49	-		M175065200	5.08	24.28	19.43	15.40
	M265065150	4.79	30.24	23.32	-		M175065220	5.56	27.52	22.02	16.85
	M265065160	5.13	32.74	24.86	-		M175065250	6.35	32.14	25.71	18.99
	M265065180	5.76	39.93	29.51	-		M205065120	3.29	12.30	9.84	-
	M265065200	6.43	46.30	35.06	-		M205065130	3.58	14.40	11.52	-
	M265065220	7.03	52.50	41.61	-		M205065140	3.84	16.56	13.25	15.85
	M265065250	8.03	63.76	49.32	-		M205065150	4.13	18.74	14.99	16.96
	M265065270	8.70	69.99	54.32	-		M205065160	4.41	20.94	16.75	18.06
6.0	M145065120	2.75	9.34	7.47	7.09		M205065170	4.67	23.13	18.23	19.17
	M145065130	2.99	10.92	8.73	7.67		M205065180	4.96	24.44	19.55	20.24
	M145065140	3.21	12.55	10.04	8.25		M205065200	5.53	28.07	22.46	22.40
	M145065150	3.45	14.21	11.37	8.82		M205065220	6.05	31.88	25.50	24.52
	M145065160	3.69	15.87	12.70	9.39		M205065250	6.91	37.30	29.84	27.65
	M145065180	4.15	19.14	15.31	10.52		M205065270	7.49	40.79	32.63	29.69
	M145065200	4.63	22.25	17.80	11.62		M235065130	3.86	17.18	13.74	-
	M145065220	5.06	25.19	20.15	12.71		M235065140	4.14	19.78	15.82	-
	M175065120	3.02	11.59	9.27	11.00		M235065150	4.45	22.40	17.93	-
	M175065130	3.29	13.57	10.85	11.91		M235065160	4.76	24.89	19.98	-
	M175065140	3.52	15.60	12.48	12.81		M235065170	5.04	27.14	21.71	26.51
	M175065150	3.79	17.46	13.97	13.70		M235065180	5.35	29.58	23.67	28.04
	M175065160	4.05	19.00	15.20	14.59		M235065200	5.97	33.81	27.04	31.03
	M175065180	4.55	22.93	18.35	16.34		M235065220	6.53	38.52	32.50	33.98
	M175065200	5.08	26.16	20.93	18.07		M235065250	7.46	45.16	38.10	38.34
	M175065220	5.56	29.67	23.74	19.78		M235065270	8.08	49.45	41.72	41.20
	M175065250	6.35	34.67	27.74	22.28		M265065140	4.46	22.41	17.91	-
	M205065120	3.29	13.14	10.52	-		M265065150	4.79	26.34	20.85	-
	M205065130	3.58	15.41	12.33	-		M265065160	5.13	28.44	22.65	-
	M205065140	3.84	17.74	14.20	-		M265065180	5.76	34.53	26.59	-
	M205065150	4.13	20.11	16.09	19.90		M265065200	6.43	39.92	31.32	-
	M205065160	4.41	22.48	17.99	21.19		M265065220	7.03	45.16	36.72	-
	M205065170	4.67	24.85	19.59	22.50		M265065250	8.03	54.70	43.12	51.24
	M205065180	4.96	26.28	21.02	23.76		M265065270	8.70	59.96	47.27	55.07
	M205065200	5.53	30.22	24.17	26.29		M300090150	5.86	27.41	20.99	-
	M205065220	6.05	34.34	27.47	28.78		M300090160	6.27	31.68	24.38	-
	M205065250	6.91	40.22	32.17	32.45		M300090180	7.05	41.69	31.45	-

- indicates the load to produce a deflection of span/180 exceeds ultimate UDL capacity

Span (m)	Section	Weight kg/m	Ultimate UDL Gravity kN	Ultimate UDL Suction kN	Load to Produce Deflection L/180 kN
	M300090200	7.86	49.40	37.25	-
	M300090250	9.82	71.53	57.47	-
	M300090270	10.64	80.43	55.40	-
	M350090150	6.43	33.70	24.97	-
	M350090160	6.87	39.19	28.94	-
	M350090180	7.72	50.59	36.98	-
	M350090200	8.62	60.16	44.00	-
	M350090250	10.77	81.46	60.90	-
	M350090270	11.66	90.78	68.44	-
	7.0	M175065120	3.02	10.15	8.12
	M175065130	3.29	11.85	9.48	8.75
	M175065140	3.52	13.60	10.88	9.41
	M175065150	3.79	15.19	12.15	10.07
	M175065160	4.05	16.51	13.21	10.72
	M175065180	4.55	19.88	15.91	12.01
	M175065200	5.08	22.65	18.12	13.28
	M175065220	5.56	25.66	20.53	14.53
	M175065250	6.35	29.94	23.95	16.37
	M205065120	3.29	11.56	9.25	-
	M205065130	3.58	13.51	10.81	12.70
	M205065140	3.84	15.52	12.41	13.67
	M205065150	4.13	17.55	14.04	14.62
	M205065160	4.41	19.59	15.67	15.57
	M205065170	4.67	21.62	17.05	16.53
	M205065180	4.96	22.84	18.27	17.45
	M205065200	5.53	26.21	20.97	19.31
	M205065220	6.05	29.74	23.79	21.14
	M205065250	6.91	34.78	27.82	23.84
	M205065270	7.49	38.02	30.41	25.60
	M235065130	3.86	16.15	12.92	-
	M235065140	4.14	18.56	14.85	-
	M235065150	4.45	21.01	16.81	20.24
	M235065160	4.76	23.11	18.71	21.56
	M235065170	5.04	25.41	20.32	22.86
	M235065180	5.35	27.67	22.14	24.17
	M235065200	5.97	31.60	25.27	26.76
	M235065220	6.53	35.97	30.34	29.30
	M235065250	7.46	42.13	35.54	33.06
	M235065270	8.08	46.11	38.90	35.52
	M265065140	4.46	21.07	16.84	-
	M265065150	4.79	24.74	19.58	-
	M265065160	5.13	26.68	21.32	-
	M265065180	5.76	32.34	25.27	32.27
	M265065200	6.43	37.34	29.69	35.73
	M265065220	7.03	42.20	34.31	39.14
	M265065250	8.03	51.07	40.26	44.18
	M265065270	8.70	55.95	44.11	47.48
	M300090150	5.86	26.05	20.84	-
	M300090160	6.27	30.02	24.02	-
	M300090180	7.05	39.35	30.65	-
	M300090200	7.86	46.50	36.04	-
	M300090250	9.82	67.06	54.98	-
	M300090270	10.64	75.33	52.84	-
	M350090150	6.43	32.22	24.65	-
	M350090160	6.87	37.33	28.55	-
	M350090180	7.72	47.93	36.66	-
	M350090200	8.62	56.80	43.13	-
	M350090250	10.77	76.52	58.75	-
	M350090270	11.66	85.17	65.76	-
7.5	M175065120	3.02	9.47	7.64	7.04

Span (m)	Section	Weight kg/m	Ultimate UDL Gravity kN	Ultimate UDL Suction kN	Load to Produce Deflection L/180 kN
	M175065130	3.29	11.06	8.91	7.62
	M175065140	3.52	12.69	10.22	8.20
	M175065150	3.79	14.18	11.41	8.77
	M175065160	4.05	15.41	12.39	9.34
	M175065180	4.55	18.56	14.91	10.46
	M175065200	5.08	21.14	16.98	11.57
	M175065220	5.56	23.94	19.22	12.66
	M175065250	6.35	27.95	22.42	14.26
	M205065120	3.29	10.90	8.72	10.22
	M205065130	3.58	12.72	10.18	11.06
	M205065140	3.84	14.60	11.68	11.91
	M205065150	4.13	16.49	13.20	12.74
	M205065160	4.41	18.40	14.72	13.56
	M205065170	4.67	20.30	16.00	14.40
	M205065180	4.96	21.43	17.14	15.20
	M205065200	5.53	24.58	19.66	16.82
	M205065220	6.05	27.87	22.30	18.42
	M205065250	6.91	32.58	26.06	20.77
	M205065270	7.49	35.60	28.47	22.30
	M235065130	3.86	15.23	12.18	-
	M235065140	4.14	17.48	13.99	16.48
	M235065150	4.45	19.77	15.82	17.63
	M235065160	4.76	21.57	17.60	18.78
	M235065170	5.04	23.87	19.10	19.92
	M235065180	5.35	25.93	20.79	21.06
	M235065200	5.97	29.65	23.71	23.31
	M235065220	6.53	33.73	28.46	25.53
	M235065250	7.46	39.48	33.31	28.80
	M235065270	8.08	43.20	36.44	30.94
	M265065140	4.46	19.87	15.88	-
	M265065150	4.79	23.31	18.45	-
	M265065160	5.13	25.11	20.07	25.06
	M265065180	5.76	30.40	24.06	28.11
	M265065200	6.43	35.07	27.88	31.12
	M265065220	7.03	39.60	32.20	34.09
	M265065250	8.03	47.88	37.75	38.49
	M265065270	8.70	52.44	41.34	41.36
	M300090150	5.86	24.79	19.83	-
	M300090160	6.27	28.50	22.80	-
	M300090180	7.05	37.24	29.01	-
	M300090200	7.86	43.91	34.03	-
	M300090250	9.82	63.11	51.74	62.67
	M300090270	10.64	70.83	50.44	67.43
	M350090150	6.43	30.82	23.57	-
	M350090160	6.87	35.59	27.22	-
	M350090180	7.72	45.50	34.80	-
	M350090200	8.62	53.76	40.83	-
	M350090250	10.77	72.13	56.61	-
	M350090270	11.66	80.20	63.15	-
8.0	M205065120	3.29	10.31	8.25	8.98
	M205065130	3.58	12.02	9.61	9.73
	M205065140	3.84	13.78	11.02	10.46
	M205065150	4.13	15.56	12.45	11.20
	M205065160	4.41	17.34	13.88	11.92
	M205065170	4.67	19.13	15.08	12.66
	M205065180	4.96	20.19	16.15	13.36

- indicates the load to produce a deflection of span/180 exceeds ultimate UDL capacity

Multibeam Purlins - Load Tables

Table 1:13 Double span and single span sleeved (Cont.)

Span (m)	Section	Weight kg/m	Ultimate UDL Gravity kN	Ultimate UDL Suction kN	Load to Produce Deflection L/180 kN	Span (m)	Section	Weight kg/m	Ultimate UDL Gravity kN	Ultimate UDL Suction kN	Load to Produce Deflection L/180 kN	
8.5	M205065200	5.53	23.14	18.51	14.79	9.0	M265065220	7.03	35.26	28.66	26.54	
	M205065220	6.05	26.23	20.98	16.19		M265065250	8.03	42.57	33.56	29.96	
	M205065250	6.91	30.63	24.50	18.25		M265065270	8.70	46.59	36.73	32.20	
	M205065270	7.49	33.47	26.77	19.60		M300090150	5.86	22.56	18.05	-	
	M235065130	3.86	14.41	11.52	13.46		M300090160	6.27	25.85	20.68	-	
	M235065140	4.14	16.52	13.22	14.48		M300090180	7.05	33.60	26.17	-	
	M235065150	4.45	18.66	14.93	15.50		M300090200	7.86	39.48	30.60	39.35	
	M235065160	4.76	20.22	16.60	16.51		M300090250	9.82	56.43	46.27	48.79	
	M235065170	5.04	22.52	18.01	17.50		M300090270	10.64	63.25	46.14	52.50	
	M235065180	5.35	24.31	19.60	18.51		M350090150	6.43	28.26	21.61	-	
	M235065200	5.97	27.93	22.33	20.49		M350090160	6.87	32.48	24.84	-	
	M235065220	6.53	31.75	26.79	22.44		M350090180	7.72	41.25	31.55	-	
	M235065250	7.46	37.14	31.33	25.31		M350090200	8.62	48.52	36.85	-	
	M235065270	8.08	40.63	34.27	27.20		M350090250	10.77	64.67	52.52	-	
	M265065140	4.46	18.80	15.03	-		M350090270	11.66	71.78	58.30	-	
	M265065150	4.79	22.03	17.44	20.67		M205065120	3.29	9.29	7.44	7.10	
	M265065160	5.13	23.72	18.96	22.02		M205065130	3.58	10.82	8.65	7.68	
	M265065180	5.76	28.68	22.95	24.70		M205065140	3.84	12.38	9.91	8.27	
	M265065200	6.43	33.05	26.28	27.35		M205065150	4.13	13.97	11.18	8.85	
	M265065220	7.03	37.31	30.33	29.97		M205065160	4.41	15.56	12.45	9.42	
	M265065250	8.03	45.07	35.53	33.83		M205065170	4.67	17.15	13.52	10.00	
	M265065270	8.70	49.34	38.90	36.35		M205065180	4.96	18.08	14.47	10.56	
	M300090150	5.86	23.63	18.91	-		M205065200	5.53	20.70	16.56	11.68	
	M300090160	6.27	27.12	21.69	-		M205065220	6.05	23.45	18.76	12.79	
	M300090180	7.05	35.33	27.52	-		M205065250	6.91	27.37	21.89	14.42	
	M300090200	7.86	41.58	32.23	-		M205065270	7.49	29.88	23.90	15.49	
	M300090250	9.82	59.59	48.85	55.08		M235065130	3.86	12.99	10.39	10.63	
	M300090270	10.64	66.83	48.21	59.27		M235065140	4.14	14.88	11.90	11.44	
	M350090150	6.43	29.50	22.56	-		M235065150	4.45	16.79	13.43	12.24	
	M350090160	6.87	33.98	25.98	-		M235065160	4.76	17.98	14.92	13.04	
	M350090180	7.72	43.29	33.11	-		M235065170	5.04	20.21	16.17	13.83	
	M350090200	8.62	51.02	38.74	-		M235065180	5.35	21.61	17.58	14.62	
M350090250	10.77	68.21	54.52	-	M235065200	5.97	25.02	20.01	16.19			
M350090270	11.66	75.76	60.66	-	M235065220	6.53	28.42	23.98	17.73			
8.5	M205065120	3.29	9.77	7.82	7.96	M235065250	7.46	33.21	28.02	20.00		
	M205065130	3.58	11.39	9.11	8.61	M235065270	8.08	36.30	30.63	21.49		
	M205065140	3.84	13.04	10.43	9.27	M265065140	4.46	16.97	13.56	15.26		
	M205065150	4.13	14.72	11.78	9.92	M265065150	4.79	19.85	15.71	16.34		
	M205065160	4.41	16.40	13.12	10.56	M265065160	5.13	21.34	17.06	17.40		
	M205065170	4.67	18.08	14.26	11.21	M265065180	5.76	25.76	20.78	19.52		
	M205065180	4.96	19.08	15.26	11.84	M265065200	6.43	29.64	23.57	21.61		
	M205065200	5.53	21.85	17.48	13.10	M265065220	7.03	33.42	27.17	23.68		
	M205065220	6.05	24.76	19.81	14.34	M265065250	8.03	40.33	31.79	26.73		
	M205065250	6.91	28.91	23.12	16.17	M265065270	8.70	44.12	34.78	28.72		
	M205065270	7.49	31.57	25.26	17.36	M300090150	5.86	21.58	17.26	-		
	M235065130	3.86	13.66	10.93	11.92	M300090160	6.27	24.69	19.75	-		
	M235065140	4.14	15.66	12.53	12.83	M300090180	7.05	32.02	24.94	31.67		
	M235065150	4.45	17.68	14.14	13.73	M300090200	7.86	37.57	29.12	35.10		
	M235065160	4.76	19.03	15.72	14.62	M300090250	9.82	53.59	43.94	43.52		
	M235065170	5.04	21.30	17.04	15.50	M300090270	10.64	60.03	44.22	46.83		
	M235065180	5.35	22.88	18.54	16.39	M350090150	6.43	27.10	20.73	-		
	M235065200	5.97	26.40	21.11	18.15	M350090160	6.87	31.10	23.78	-		
	M235065220	6.53	29.99	25.31	19.87	M350090180	7.72	39.39	30.13	-		
	M235065250	7.46	35.07	29.58	22.42	M350090200	8.62	46.25	35.13	-		
	M235065270	8.08	38.34	32.35	24.09	M350090250	10.77	61.48	50.61	-		
	M265065140	4.46	17.84	14.26	17.11	M350090270	11.66	68.20	56.08	67.81		
	M265065150	4.79	20.88	16.53	18.31							
	M265065160	5.13	22.47	17.96	19.51							
	M265065180	5.76	27.14	21.89	21.88							
	M265065200	6.43	31.26	24.85	24.23							

- indicates the load to produce a deflection of span/180 exceeds ultimate UDL capacity

Span (m)	Section	Weight kg/m	Ultimate UDL Gravity kN	Ultimate UDL Suction kN	Load to Produce Deflection L/180 kN
9.5	M235065130	3.86	12.31	9.91	9.54
	M235065140	4.14	14.10	11.34	10.27
	M235065150	4.45	15.90	12.79	10.99
	M235065160	4.76	17.03	14.20	11.70
	M235065170	5.04	19.14	15.38	12.41
	M235065180	5.35	20.47	16.72	13.12
	M235065200	5.97	23.70	19.02	14.53
	M235065220	6.53	26.92	22.78	15.91
	M235065250	7.46	31.46	26.61	17.95
	M235065270	8.08	34.39	29.08	19.29
	M265065140	4.46	16.07	12.93	13.70
	M265065150	4.79	18.81	14.97	14.66
	M265065160	5.13	20.22	16.24	15.62
	M265065180	5.76	24.41	19.77	17.52
	M265065200	6.43	28.08	22.41	19.40
	M265065220	7.03	31.66	25.83	21.25
	M265065250	8.03	38.21	30.20	23.99
	M265065270	8.70	41.80	33.04	25.78
	M300090150	5.86	20.44	16.54	-
	M300090160	6.27	23.39	18.90	-
	M300090180	7.05	30.33	23.82	28.42
	M300090200	7.86	35.59	27.77	31.50
	M300090250	9.82	50.77	41.83	39.06
	M300090270	10.64	56.87	42.44	42.03
	M350090150	6.43	26.03	19.91	-
	M350090160	6.87	29.81	22.80	-
	M350090180	7.72	37.32	28.82	-
	M350090200	8.62	43.82	33.55	-
	M350090250	10.77	58.25	48.80	56.54
	M350090270	11.66	64.61	53.98	60.86
10.0	M235065130	3.86	11.69	9.46	8.61
	M235065140	4.14	13.39	10.82	9.27
	M235065150	4.45	15.11	12.20	9.92
	M235065160	4.76	16.18	13.54	10.56
	M235065170	5.04	18.19	14.66	11.20
	M235065180	5.35	19.45	15.94	11.85
	M235065200	5.97	22.52	18.12	13.11
	M235065220	6.53	25.58	21.70	14.36
M235065250	7.46	29.89	25.33	16.20	
M235065270	8.08	32.68	27.68	17.41	

Span (m)	Section	Weight kg/m	Ultimate UDL Gravity kN	Ultimate UDL Suction kN	Load to Produce Deflection L/180 kN
9.5	M265065140	4.46	15.27	12.35	12.36
	M265065150	4.79	17.87	14.29	13.23
	M265065160	5.13	19.21	15.50	14.10
	M265065180	5.76	23.19	18.85	15.81
	M265065200	6.43	26.68	21.36	17.51
	M265065220	7.03	30.08	24.61	19.18
	M265065250	8.03	36.30	28.77	21.65
	M265065270	8.70	39.71	31.46	23.27
	M300090150	5.86	19.42	15.86	-
	M300090160	6.27	22.22	18.11	-
	M300090180	7.05	28.82	22.79	25.65
	M300090200	7.86	33.82	26.55	28.43
	M300090250	9.82	48.23	39.91	35.25
	M300090270	10.64	54.03	40.78	37.93
	M350090150	6.43	25.02	19.14	-
	M350090160	6.87	28.62	21.89	-
	M350090180	7.72	35.45	27.62	-
	M350090200	8.62	41.63	32.11	41.12
	M350090250	10.77	55.34	47.09	51.03
	M350090270	11.66	61.38	52.02	54.93

- indicates the load to produce a deflection of span/180 exceeds ultimate UDL capacity

Cleader Angle Wind Loadings (Ultimate)

Maximum horizontal wind loading which can be carried by the Kingspan 70x70x2.7mm cleader angle.

Span between purlins (m)	Maximum UDL (wind) kN
1.0	3.78
1.2	3.17
1.4	2.73
1.6	2.38
1.8	2.11
2.0	1.90

Multibeam Purlins Tiled Roofs

Loads are Ultimate vertical (on slope) and in kN and kN/m².

The designer should not resolve the loadings into normal and downslope components as they have been taken into account when compiling this table. Loads are based on the utilisation of an anti-sag system comprising angle struts at 1/3 span with diagonal rod ties at a minimum slope to the purlins of 30° and stiffened cleats. In order to maintain 30° on larger bays, struts should be positioned at 1/4 intervals as shown on page 14 in the Multibeam Handbook.

One set of diagonal rods are required per 6m length of roof slope.

The loads are applicable to roof slopes not exceeding 30° and purlin spacings not exceeding 1.8m.

Timber rafters must be securely fixed to the purlins at centres not exceeding 600mm. Where metal decking is used with tiles consult our Technical Department.

Table 1:14 Tiled Roof Double Span Load Tables (Ultimate)

Span (m)	Section	UDL kN	Purlin Centres m				
			1.2	1.375	1.5	1.675	1.8
5.0	M205065150	20.85	3.48	3.03	2.78	2.49	2.32
	M205065160	23.06	3.84	3.35	3.08	2.75	2.56
	M205065180	24.14	4.02	3.51	3.22	2.88	2.68
	M235065160	24.14	4.02	3.51	3.22	2.88	2.68
5.5	M205065150	19.17	2.90	2.53	2.32	2.08	1.94
	M205065160	21.17	3.21	2.80	2.57	2.30	2.14
	M235065160	23.04	3.49	3.05	2.79	2.50	2.33
	M235065180	23.04	3.49	3.05	2.79	2.50	2.33
6.0	M235065160	21.65	3.01	2.62	2.41	2.15	2.00
	M235065180	22.00	3.06	2.67	2.44	2.19	2.04
	M235065200	22.00	3.06	2.67	2.44	2.19	2.04
6.5	M235065160	20.13	2.58	2.25	2.07	1.85	1.72
	M235065180	21.02	2.69	2.35	2.16	1.93	1.80
	M235065200	21.02	2.69	2.35	2.16	1.93	1.80
7.0	M235065160	18.81	2.24	1.95	1.79	1.60	1.49
	M235065180	20.10	2.39	2.09	1.91	1.71	1.60
	M235065200	20.10	2.39	2.09	1.91	1.71	1.60

Multibeam Purlins - Load Tables

Multibeam Purlins Continuous System

Table 1:15 Double Span

Span (m)	Section	Self Weight kg/m	Gravity kN	External Bay Uplift kN			Defl Limit L/180 kN	Internal Bay Uplift kN			Defl Limit L/180 kN	
				No	One	Two		Gravity kN	No	One		Two
6.0	M175065120	3.02	11.93	11.93	11.93	11.93	8.69	15.64	15.64	15.64	15.64	18.11
	M175065130	3.29	13.99	13.99	13.99	13.99	9.37	18.32	18.32	18.32	18.32	19.54
	M175065140	3.52	16.10	16.10	16.10	16.10	10.05	21.09	21.09	21.09	21.09	20.95
	M175065150	3.79	18.15	18.15	18.15	18.15	10.71	23.75	23.75	23.75	23.75	22.33
	M175065160	4.05	20.04	20.04	20.04	20.04	11.37	26.22	26.22	26.22	26.22	23.69
	M175065180	4.55	24.22	24.22	24.22	24.22	12.65	31.66	31.66	31.66	31.66	26.37
	M175065200	5.08	27.94	27.94	27.94	27.94	13.89	36.51	36.51	36.51	36.51	28.96
	M175065220	5.56	31.70	31.70	31.70	31.70	15.11	41.41	41.41	41.41	41.41	31.49
	M175065250	6.35	37.06	37.06	37.06	37.06	16.85	48.39	48.39	48.39	48.39	35.13
	M205605120	3.29	14.08	14.08	14.08	14.08	12.57	18.10	18.10	18.10	18.10	26.20
	M205605130	3.58	16.54	16.54	16.54	16.54	13.56	21.28	21.28	21.28	21.28	28.26
	M205605140	3.84	19.06	19.06	19.06	19.06	14.53	24.57	24.57	24.57	24.57	30.30
	M205605150	4.13	21.62	21.62	21.62	21.62	15.49	27.89	27.89	27.89	27.89	32.30
	M205605160	4.41	24.19	24.19	24.19	24.19	16.44	31.24	31.24	31.24	31.24	34.26
	M205605170	4.67	26.76	26.76	26.76	26.76	17.39	34.58	34.58	34.58	34.58	36.26
	M205605180	4.96	28.82	28.82	28.82	28.82	18.29	37.27	37.27	37.27	37.27	38.13
	M205605200	5.53	33.41	33.41	33.41	33.41	20.09	43.24	43.24	43.24	43.24	41.87
	M205605220	6.05	37.96	37.96	37.96	37.96	21.84	49.18	49.18	49.18	49.18	45.53
	M205605250	6.91	44.48	44.48	44.48	44.48	24.36	57.67	57.67	57.67	57.67	50.78
	M235065270	7.49	48.67	48.67	48.67	48.67	25.97	63.13	63.13	63.13	63.13	54.14
	M235065130	3.86	19.69	17.11	19.69	19.69	18.69	24.86	21.61	24.86	24.86	38.95
	M235065140	4.14	22.73	19.72	22.73	22.73	20.03	28.80	24.98	28.80	28.80	41.76
	M235065150	4.45	25.81	22.31	25.81	25.81	21.35	32.79	28.36	32.79	32.79	44.51
	M235065160	4.76	28.85	24.94	28.85	28.85	22.65	36.76	31.78	36.76	36.76	47.22
M235065170	5.04	31.69	27.31	31.69	31.69	23.93	40.44	34.85	40.44	40.44	49.89	
M235065180	5.35	34.64	29.83	34.64	34.64	25.20	44.28	38.13	44.28	44.28	52.54	
M235065200	5.97	40.09	34.49	40.09	40.09	27.67	51.38	44.21	51.38	51.38	57.68	
M235065220	6.53	45.66	41.26	45.66	45.66	30.09	58.64	52.99	58.64	58.64	62.72	
M235065250	7.46	53.60	48.37	53.60	53.60	33.55	68.99	62.26	68.99	68.99	69.93	
M235065270	8.08	58.74	53.00	58.74	58.74	35.76	75.68	68.29	75.68	75.68	74.55	
6.5	M175065120	3.02	11.10	11.10	11.10	11.10	7.40	14.70	14.70	14.70	14.70	15.43
	M175065130	3.29	13.00	13.00	13.00	13.00	7.99	17.18	17.18	17.18	17.18	16.65
	M175065140	3.52	14.96	14.96	14.96	14.96	8.56	19.73	19.73	19.73	19.73	17.85
	M175065150	3.79	16.84	16.84	16.84	16.84	9.13	22.19	22.19	22.19	22.19	19.03
	M175065160	4.05	18.58	18.58	18.58	18.58	9.68	24.47	24.47	24.47	24.47	20.19
	M175065180	4.55	22.44	22.44	22.44	22.44	10.78	29.48	29.48	29.48	29.48	22.47
	M175065200	5.08	25.86	25.86	25.86	25.86	11.84	33.96	33.96	33.96	33.96	24.68
	M175065220	5.56	29.33	29.33	29.33	29.33	12.87	38.47	38.47	38.47	38.47	26.83
	M175065250	6.35	34.26	34.26	34.26	34.26	14.36	44.90	44.90	44.90	44.90	29.93
	M205605120	3.29	13.14	13.14	13.14	13.14	10.71	17.08	17.08	17.08	17.08	22.33
	M205605130	3.58	15.41	15.41	15.41	15.41	11.55	20.03	20.03	20.03	20.03	24.08
	M205605140	3.84	17.75	17.75	17.75	17.75	12.38	23.07	23.07	23.07	23.07	25.82
	M205605150	4.13	20.10	20.10	20.10	20.10	13.20	26.14	26.14	26.14	26.14	27.52
	M205605160	4.41	22.47	22.47	22.47	22.47	14.00	29.23	29.23	29.23	29.23	29.19
	M205605170	4.67	24.84	24.84	24.84	24.84	14.82	32.32	32.32	32.32	32.32	30.89
	M205605180	4.96	26.74	26.74	26.74	26.74	15.58	34.79	34.79	34.79	34.79	32.49
	M205605200	5.53	30.97	30.95	30.97	30.97	17.12	40.29	40.27	40.29	40.29	35.68
	M205605220	6.05	35.17	34.67	35.17	35.17	18.61	45.77	45.13	45.77	45.77	38.80
	M205605250	6.91	41.16	39.91	41.16	41.16	20.76	53.59	51.96	53.59	53.59	43.27
	M205605270	7.49	45.03	43.24	45.03	45.03	22.13	58.62	56.30	58.62	58.62	46.13
	M235065130	3.86	18.40	12.64	18.40	18.40	15.92	23.50	16.16	23.50	23.50	33.19
	M235065140	4.14	21.20	14.57	21.20	21.20	17.07	27.14	18.67	27.14	27.14	35.59
	M235065150	4.45	24.04	16.50	24.04	24.04	18.19	30.84	21.17	30.84	30.84	37.93
	M235065160	4.76	26.85	18.46	26.85	26.85	19.30	34.50	23.72	34.50	34.50	40.23
M235065170	5.04	29.46	20.22	29.46	29.46	20.39	37.90	26.01	37.90	37.90	42.51	
M235065180	5.35	32.19	22.10	32.19	32.19	21.47	41.44	28.46	41.44	41.44	44.77	
M235065200	5.97	37.21	25.59	37.21	37.21	23.58	47.98	33.00	47.98	47.98	49.15	
M235065220	6.53	42.34	30.82	42.34	42.34	25.64	54.67	39.79	54.67	54.67	53.44	
M235065250	7.46	49.66	36.21	49.66	49.66	28.58	64.21	46.83	64.21	64.21	59.58	
M235065270	8.08	54.39	39.74	54.39	54.39	30.47	70.38	51.43	70.38	70.38	63.52	

Span (m)	Section	Self Weight kg/m	Gravity kN	External Bay Uplift kN			Defl Limit L/180 kN	Internal Bay Uplift kN				Defl Limit L/180 kN
				No	One	Two		Gravity kN	No	One	Two	
7.0	M175065120	3.02	10.37	8.76	10.37	10.37	6.38	13.85	11.70	13.85	13.85	13.31
	M175065130	3.29	12.13	10.21	12.13	12.13	6.88	16.16	13.60	16.16	16.16	14.35
	M175065140	3.52	13.95	11.70	13.95	13.95	7.38	18.53	15.55	18.53	18.53	15.39
	M175065150	3.79	15.69	13.16	15.69	15.69	7.87	20.81	17.44	20.81	20.81	16.41
	M175065160	4.05	17.31	14.49	17.31	17.31	8.35	22.92	19.18	22.92	22.92	17.41
	M175065180	4.55	20.89	17.45	20.89	20.89	9.29	27.58	23.04	27.58	27.58	19.37
	M175065200	5.08	24.06	20.05	24.06	24.06	10.21	31.72	26.43	31.72	31.72	21.28
	M175065220	5.56	27.27	22.72	27.27	27.27	11.10	35.90	29.90	35.90	35.90	23.14
	M175065250	6.35	31.84	26.51	31.84	31.84	12.38	41.86	34.85	41.86	41.86	25.81
	M205605120	3.29	12.31	10.38	12.31	12.31	9.23	16.16	13.63	16.16	16.16	19.25
	M205605130	3.58	14.41	12.10	14.41	14.41	9.96	18.90	15.86	18.90	18.90	20.76
	M205605140	3.84	16.58	13.90	16.58	16.58	10.68	21.72	18.22	21.72	21.72	22.26
	M205605150	4.13	18.77	15.69	18.77	18.77	11.38	24.58	20.55	24.58	24.58	23.73
	M205605160	4.41	20.97	17.51	20.97	20.97	12.08	27.45	22.92	27.45	27.45	25.17
	M205605170	4.67	23.17	19.03	23.17	23.17	12.78	30.31	24.89	30.31	30.31	26.64
	M205605180	4.96	24.93	20.76	24.93	24.93	13.44	32.61	27.16	32.61	32.61	28.01
	M205605200	5.53	28.84	23.48	28.84	28.84	14.76	37.71	30.70	37.71	37.71	30.76
	M205605220	6.05	32.73	26.34	32.73	32.73	16.05	42.78	34.43	42.78	42.78	33.45
	M205605250	6.91	38.29	30.39	38.29	38.29	17.90	50.03	39.70	50.03	50.03	37.31
	M205605270	7.49	41.86	32.96	41.86	41.86	19.08	54.69	43.06	54.69	54.69	39.77
	M235065130	3.86	17.24	9.53	14.43	17.24	13.73	22.25	12.31	18.63	22.25	28.62
	M235065140	4.14	19.85	10.99	16.54	19.85	14.72	25.64	14.20	21.37	25.64	30.68
	M235065150	4.45	22.48	12.45	18.73	22.48	15.69	29.07	16.09	24.21	29.07	32.70
	M235065160	4.76	25.10	13.92	21.11	25.10	16.64	32.47	18.02	27.32	32.47	34.69
	M235065170	5.04	27.52	15.26	22.84	27.52	17.58	35.63	19.75	29.58	35.63	36.65
	M235065180	5.35	30.04	16.68	24.93	30.04	18.52	38.92	21.61	32.29	38.92	38.60
	M235065200	5.97	34.69	19.33	28.74	34.69	20.33	44.98	25.06	37.26	44.98	42.38
	M235065220	6.53	39.45	23.35	34.42	39.45	22.10	51.19	30.30	44.65	51.19	46.08
M235065250	7.46	46.24	27.50	40.31	46.24	24.65	60.03	35.70	52.33	60.03	51.38	
M235065270	8.08	50.62	30.21	44.10	50.62	26.27	65.74	39.24	57.28	65.74	54.77	
7.5	M175065120	3.02	9.72	6.73	9.72	9.72	5.56	13.08	9.05	13.08	13.08	11.59
	M175065130	3.29	11.37	7.85	11.37	11.37	6.00	15.23	10.52	15.23	15.23	12.50
	M175065140	3.52	13.06	9.01	13.06	13.06	6.43	17.45	12.03	17.45	17.45	13.41
	M175065150	3.79	14.69	10.13	14.69	14.69	6.86	19.58	13.51	19.58	19.58	14.29
	M175065160	4.05	16.19	11.17	16.19	16.19	7.27	21.54	14.86	21.54	21.54	15.16
	M175065180	4.55	19.52	13.47	19.52	19.52	8.10	25.89	17.87	25.89	25.89	16.88
	M175065200	5.08	22.48	15.50	22.48	22.48	8.89	29.75	20.51	29.75	29.75	18.54
	M175065220	5.56	25.47	17.58	25.47	25.47	9.67	33.65	23.23	33.65	33.65	20.16
	M175065250	6.35	29.72	20.55	29.72	29.72	10.78	39.20	27.11	39.20	39.20	22.48
	M205605120	3.29	11.57	7.97	11.57	11.57	8.04	15.31	10.55	15.31	15.31	16.77
	M205605130	3.58	13.53	9.29	13.53	13.53	8.68	17.87	12.29	17.87	17.87	18.09
	M205605140	3.84	15.55	10.70	15.55	15.55	9.30	20.51	14.11	20.51	20.51	19.39
	M205605150	4.13	17.59	12.08	17.59	17.59	9.91	23.18	15.91	23.18	23.18	20.67
	M205605160	4.41	19.64	13.49	19.64	19.64	10.52	25.85	17.75	25.85	25.85	21.93
	M205605170	4.67	21.69	14.65	21.69	21.69	11.13	28.52	19.27	28.52	28.52	23.21
	M205605180	4.96	23.33	15.94	23.33	23.33	11.70	30.66	20.96	30.66	30.66	24.40
	M205605200	5.53	26.97	18.04	26.97	26.97	12.86	35.42	23.68	35.42	35.42	26.80
	M205605220	6.05	30.60	20.26	30.60	30.60	13.98	40.14	26.57	40.14	40.14	29.14
	M205605250	6.91	35.78	23.42	35.78	35.78	15.59	46.89	30.69	46.89	46.89	32.50
	M205605270	7.49	39.10	25.43	39.10	39.10	16.62	51.23	33.32	51.23	51.23	34.65
	M235065130	3.86	16.22	7.34	16.22	16.22	11.96	21.11	9.55	21.11	21.11	24.93
	M235065140	4.14	18.65	8.45	18.65	18.65	12.82	24.28	11.00	24.28	24.28	26.73
	M235065150	4.45	21.10	9.57	21.10	21.10	13.66	27.48	12.47	27.48	27.48	28.49
	M235065160	4.76	23.54	10.71	23.54	23.54	14.50	30.65	13.94	30.65	30.65	30.22
	M235065170	5.04	25.79	11.73	25.79	25.79	15.32	33.59	15.28	33.59	33.59	31.93
	M235065180	5.35	28.15	12.83	28.15	28.15	16.13	36.66	16.71	36.66	36.66	33.62
	M235065200	5.97	32.48	14.87	32.48	32.48	17.71	42.32	19.37	42.32	42.32	36.92
	M235065220	6.53	36.92	17.98	36.92	36.92	19.26	48.10	23.42	48.10	48.10	40.14
M235065250	7.46	43.23	21.20	43.23	43.23	21.47	56.33	27.62	56.33	56.33	44.76	
M235065270	8.08	47.31	23.31	47.31	47.31	22.89	61.65	30.38	61.65	61.65	47.71	

Multibeam Purlins - Load Tables

Multibeam Purlins Continuous System

Table 1:15 Double Span (Cont.)

Span (m)	Section	Self Weight kg/m	Gravity kN	External Bay Uplift kN			Defl Limit L/180 kN	Gravity kN	Internal Bay Uplift kN			Defl Limit L/180 kN
				No	One	Two			No	One	Two	
8.0	M175065120	3.02	9.14	-	8.61	9.14	4.89	12.38	-	11.65	12.38	10.19
	M175065130	3.29	10.68	-	9.98	10.68	5.27	14.39	-	13.46	14.39	10.99
	M175065140	3.52	12.27	-	11.38	12.27	5.65	16.47	-	15.29	16.47	11.78
	M175065150	3.79	13.79	-	12.74	13.79	6.03	18.46	-	17.06	18.46	12.56
	M175065160	4.05	15.20	-	14.01	15.20	6.39	20.30	-	18.71	20.30	13.33
	M175065180	4.55	18.32	-	16.75	18.32	7.12	24.38	-	22.30	24.38	14.83
	M175065200	5.08	21.08	-	19.23	21.08	7.82	27.98	-	25.53	27.98	16.29
	M175065220	5.56	23.88	-	21.70	23.88	8.50	31.64	-	28.75	31.64	17.71
	M175065250	6.35	27.86	-	25.24	27.86	9.48	36.82	-	33.37	36.82	19.76
	M205605120	3.29	10.90	-	10.06	10.90	7.07	14.54	-	13.41	14.54	14.74
	M205605130	3.58	12.74	-	11.68	12.74	7.63	16.94	-	15.53	16.94	15.89
	M205605140	3.84	14.62	-	13.34	14.62	8.18	19.41	-	17.71	19.41	17.04
	M205605150	4.13	16.54	-	15.04	16.54	8.71	21.91	-	19.92	21.91	18.17
	M205605160	4.41	18.46	-	16.74	18.46	9.25	24.42	-	22.14	24.42	19.27
	M205605170	4.67	20.38	-	18.18	20.38	9.78	26.92	-	24.02	26.92	20.39
	M205605180	4.96	21.91	-	19.65	21.91	10.29	28.92	-	25.94	28.92	21.45
	M205605200	5.53	25.32	-	22.18	25.32	11.30	33.37	-	29.24	33.37	23.55
	M205605220	6.05	28.71	-	24.90	28.71	12.29	37.79	-	32.77	37.79	25.61
	M205605250	6.91	33.55	-	28.70	33.55	13.70	44.11	-	37.72	44.11	28.56
	M205605270	7.49	36.66	-	31.11	36.66	14.61	48.17	-	40.88	48.17	30.45
	M235065130	3.86	15.29	-	13.95	15.29	10.51	20.06	-	18.31	20.06	21.91
	M235065140	4.14	17.57	-	15.94	17.57	11.27	23.03	-	20.90	23.03	23.49
	M235065150	4.45	19.86	-	17.98	19.86	12.01	26.03	-	23.56	26.03	25.04
	M235065160	4.76	22.15	-	20.58	22.15	12.74	29.01	-	26.96	29.01	26.56
M235065170	5.04	24.26	-	21.88	24.26	13.46	31.76	-	28.64	31.76	28.06	
M235065180	5.35	26.46	-	24.06	26.46	14.18	34.63	-	31.48	34.63	29.55	
M235065200	5.97	30.52	-	27.38	30.52	15.56	39.93	-	35.82	39.93	32.45	
M235065220	6.53	34.67	-	32.65	34.67	16.92	45.34	-	42.70	45.34	35.28	
M235065250	7.46	40.58	-	38.10	40.58	18.87	53.04	-	49.80	53.04	39.34	
M235065270	8.08	44.39	-	41.63	44.39	20.11	58.02	-	54.42	58.02	41.93	
8.5	M205605120	3.29	10.29	-	7.96	10.29	6.26	13.82	-	10.69	13.82	13.05
	M205605130	3.58	12.02	-	9.26	12.02	6.75	16.08	-	12.39	16.08	14.08
	M205605140	3.84	13.80	-	10.59	13.80	7.24	18.41	-	14.14	18.41	15.10
	M205605150	4.13	15.60	-	11.94	15.60	7.72	20.77	-	15.90	20.77	16.09
	M205605160	4.41	17.40	-	13.31	17.40	8.19	23.12	-	17.68	23.12	17.07
	M205605170	4.67	19.20	-	14.46	19.20	8.68	25.48	-	19.18	25.48	18.06
	M205605180	4.96	20.64	-	15.61	20.64	9.11	27.35	-	20.67	27.35	19.00
	M205605200	5.53	23.84	-	17.65	23.67	10.01	31.54	-	23.33	31.31	20.86
	M205605220	6.05	27.03	-	19.82	26.52	10.88	35.69	-	26.17	35.02	22.69
	M205605250	6.91	31.57	-	22.89	30.54	12.14	41.62	-	30.18	40.26	25.30
	M205605270	7.49	34.48	-	24.85	33.10	12.94	45.43	-	32.73	43.60	26.97
	M235065130	3.86	14.45	-	11.05	14.45	9.31	19.09	-	14.60	19.09	19.41
	M235065140	4.14	16.59	-	12.64	16.59	9.98	21.89	-	16.68	21.89	20.81
	M235065150	4.45	18.76	-	14.26	18.76	10.64	24.72	-	18.79	24.72	22.18
	M235065160	4.76	20.90	-	16.38	20.90	11.29	27.51	-	21.56	27.51	23.53
	M235065170	5.04	22.89	-	17.39	22.89	11.92	30.11	-	22.87	30.11	24.86
	M235065180	5.35	24.96	-	19.14	24.96	12.56	32.81	-	25.17	32.81	26.18
	M235065200	5.97	28.76	-	21.81	28.76	13.79	37.77	-	28.64	37.77	28.74
	M235065220	6.53	32.67	-	26.18	32.67	14.99	42.87	-	34.36	42.87	31.25
	M235065250	7.46	38.21	-	30.63	38.21	16.72	50.10	-	40.15	50.10	34.84
	M235065270	8.08	41.79	-	33.52	41.79	17.82	54.77	-	43.92	54.77	37.14
	M265065140	4.46	19.24	-	14.57	19.24	13.26	25.08	-	19.01	25.08	27.64
	M265065150	4.79	22.13	-	16.56	22.13	14.13	28.85	-	21.60	28.85	29.46
	M265065160	5.13	24.28	-	18.37	24.28	14.99	31.67	-	23.95	31.67	31.24
M265065180	5.76	29.33	-	22.24	29.33	16.67	38.24	-	28.99	38.24	34.76	
M265065200	6.43	33.98	-	25.49	33.98	18.30	44.32	-	33.24	44.32	38.15	
M265065220	7.03	38.48	-	29.53	38.48	19.90	50.18	-	38.51	50.18	41.48	
M265065250	8.03	45.72	-	33.95	45.57	22.18	59.63	-	44.28	59.43	46.23	
M265065270	8.70	50.05	-	37.20	49.74	23.63	65.27	-	48.52	64.87	49.27	

Span (m)	Section	Self Weight kg/m	Gravity kN	External Bay Uplift kN			Defl Limit L/180 kN	Gravity kN	Internal Bay Uplift kN			Defl Limit L/180 kN
				No	One	Two			No	One	Two	
9.0	M205605120	3.29	9.75	-	6.37	8.78	5.59	13.17	-	8.61	11.86	11.64
	M205605130	3.58	11.38	-	7.42	10.18	6.02	15.30	-	9.98	13.70	12.56
	M205605140	3.84	13.05	-	8.50	11.62	6.46	17.50	-	11.39	15.58	13.47
	M205605150	4.13	14.75	-	9.59	13.08	6.88	19.72	-	12.82	17.49	14.35
	M205605160	4.41	16.45	-	10.68	14.55	7.30	21.95	-	14.26	19.41	15.23
	M205605170	4.67	18.15	-	11.61	15.79	7.73	24.17	-	15.46	21.02	16.11
	M205605180	4.96	19.50	-	12.51	16.97	8.13	25.94	-	16.63	22.57	16.95
	M205605200	5.53	22.52	-	14.17	19.16	8.93	29.87	-	18.79	25.43	18.61
	M205605220	6.05	25.52	-	15.93	21.50	9.71	33.80	-	21.09	28.48	20.24
	M205605250	6.91	29.80	-	18.42	24.80	10.83	39.38	-	24.35	32.79	22.57
	M205605270	7.49	32.54	-	20.03	26.92	11.54	42.97	-	26.44	35.54	24.06
	M235065130	3.86	13.70	-	8.86	12.18	8.31	18.20	-	11.76	16.18	17.31
	M235065140	4.14	15.71	-	10.13	13.91	8.90	20.84	-	13.44	18.45	18.56
	M235065150	4.45	17.76	-	11.44	15.67	9.49	23.52	-	15.15	20.75	19.78
	M235065160	4.76	19.78	-	13.15	18.06	10.07	26.15	-	17.40	23.88	20.99
	M235065170	5.04	21.65	-	13.96	19.00	10.64	28.60	-	18.44	25.09	22.17
	M235065180	5.35	23.61	-	15.39	21.03	11.20	31.15	-	20.30	27.76	23.35
	M235065200	5.97	27.19	-	17.54	23.76	12.30	35.83	-	23.11	31.31	25.64
	M235065220	6.53	30.87	-	21.15	28.34	13.37	40.63	-	27.85	37.31	27.88
	M235065250	7.46	36.09	-	24.79	33.07	14.91	47.45	-	32.59	43.47	31.08
	M235065270	8.08	39.47	-	27.16	36.11	15.89	51.85	-	35.69	47.45	33.13
	M265065140	4.46	18.24	-	11.67	16.07	11.83	23.93	-	15.32	21.09	24.66
	M265065150	4.79	20.97	-	13.28	18.21	12.60	27.50	-	17.41	23.87	26.27
	M265065160	5.13	23.00	-	14.73	20.13	13.37	30.15	-	19.31	26.39	27.87
	M265065180	5.76	27.77	-	17.86	24.40	14.87	36.36	-	23.38	31.95	31.00
	M265065200	6.43	32.15	-	20.48	27.82	16.32	42.08	-	26.82	36.41	34.03
	M265065220	7.03	36.39	-	23.77	32.12	17.75	47.61	-	31.10	42.03	37.00
	M265065250	8.03	43.21	-	27.33	36.91	19.78	56.52	-	35.75	48.28	41.24
	M265065270	8.70	47.29	-	29.86	40.33	21.08	61.84	-	39.05	52.74	43.95

Span (m)	Section	Self Weight kg/m	Gravity kN	External Uplift kN	Defl Limit L/180 kN/m ²	Internal Uplift kN		Defl Limit L/180 kN
				Three Restraints		Gravity kN	Three Restraints	
9.5	M235065130	3.86	13.01	11.16	7.46	17.39	14.67	15.54
	M235065140	4.14	14.92	12.75	7.99	19.88	16.72	16.66
	M235065150	4.45	16.85	14.36	8.52	22.41	18.81	17.76
	M235065160	4.76	18.76	15.95	9.03	24.91	20.87	18.83
	M235065170	5.04	20.53	17.42	9.55	27.23	22.77	19.90
	M235065180	5.35	22.37	18.96	10.05	29.63	24.77	20.96
	M235065200	5.97	25.76	21.78	11.04	34.07	28.42	23.01
	M235065220	6.53	29.24	25.27	12.00	38.60	32.95	25.02
	M235065250	7.46	34.17	29.50	13.38	45.05	38.41	27.89
	M235065270	8.08	37.36	32.23	14.26	49.21	41.95	29.74
	M265065140	4.46	17.33	14.74	10.61	22.87	19.17	22.13
	M265065150	4.79	19.91	16.80	11.31	26.24	21.84	23.58
	M265065160	5.13	21.84	18.48	12.00	28.76	24.01	25.01
	M265065180	5.76	26.34	22.29	13.35	34.64	28.95	27.83
	M265065200	6.43	30.49	25.59	14.65	40.05	33.22	30.54
	M265065220	7.03	34.49	29.19	15.93	45.28	37.88	33.21
	M265065250	8.03	40.95	34.12	17.75	53.70	44.26	37.01
	M265065270	8.70	44.79	37.32	18.92	58.73	48.38	39.45

Multibeam Purlins - Load Tables

Multibeam Purlins Continuous System

Table 1:15 Double Span (Cont.)

Span (m)	Section	Self Weight		External Bay Uplift kN		Internal Bay Uplift kN		Defl Limit	
		kg/m	Gravity kN	Three Restraints	L/180 kN	Gravity kN	Three Restraints	L/180 kN	L/180 kN
10.0	M235065130	3.86	12.37	10.70	6.73	16.62	14.10	14.02	
	M235065140	4.14	14.19	12.21	7.21	19.00	16.06	15.03	
	M235065150	4.45	16.02	13.74	7.69	21.40	18.05	16.02	
	M235065160	4.76	17.83	15.26	8.16	23.77	20.01	17.00	
	M235065170	5.04	19.51	16.66	8.61	25.97	21.82	17.96	
	M235065180	5.35	21.26	18.12	9.07	28.25	23.71	18.91	
	M235065200	5.97	24.47	20.81	9.96	32.45	27.20	20.77	
	M235065220	6.53	27.76	24.13	10.83	36.75	31.50	22.58	
	M235065250	7.46	32.44	28.16	12.08	42.86	36.70	25.18	
	M235065270	8.08	35.46	30.76	12.87	46.81	40.06	26.84	
	M265065140	4.46	16.50	14.12	9.58	21.88	18.42	19.97	
	M265065150	4.79	18.95	16.08	10.21	25.09	20.97	21.28	
	M265065160	5.13	20.78	17.68	10.83	27.47	23.04	22.58	
	M265065180	5.76	25.04	21.31	12.05	33.05	27.74	25.11	
	M265065200	6.43	28.98	24.45	13.22	38.19	31.80	27.56	
	M265065220	7.03	32.77	27.88	14.38	43.15	36.24	29.97	
M265065250	8.03	38.89	32.57	16.02	51.14	42.30	33.40		
M265065270	8.70	42.54	35.61	17.08	55.91	46.23	35.60		
10.5	M235065130	3.86	11.79	10.28	6.10	15.92	13.58	12.72	
	M235065140	4.14	13.51	11.72	6.54	18.18	15.45	13.64	
	M235065150	4.45	15.26	13.18	6.97	20.46	17.35	14.53	
	M235065160	4.76	16.98	14.63	7.39	22.72	19.22	15.42	
	M235065170	5.04	18.57	15.96	7.82	24.81	20.95	16.29	
	M235065180	5.35	20.24	17.36	8.23	26.99	22.75	17.15	
	M235065200	5.97	23.29	19.93	9.04	30.96	26.07	18.84	
	M235065220	6.53	26.42	23.10	9.82	35.06	30.18	20.48	
	M235065250	7.46	30.86	26.94	10.96	40.87	35.14	22.83	
	M235065270	8.08	33.73	29.43	11.68	44.61	38.35	24.34	
	M265065140	4.46	15.74	13.56	8.69	20.97	17.75	18.11	
	M265065150	4.79	18.07	15.44	9.26	24.02	20.17	19.31	
	M265065160	5.13	19.80	16.96	9.82	26.29	22.14	20.47	
	M265065180	5.76	23.86	20.42	10.93	31.59	26.63	22.78	
	M265065200	6.43	27.59	23.42	11.99	36.48	30.50	25.00	
	M265065220	7.03	31.21	26.68	13.04	41.19	34.73	27.18	
M265065250	8.03	37.01	31.16	14.53	48.79	40.52	30.29		
M265065270	8.70	40.48	34.06	15.49	53.32	44.27	32.29		
11.0	M265065140	4.46	15.04	13.04	7.92	20.12	17.11	16.50	
	M265065150	4.79	17.26	14.83	8.44	23.03	19.44	17.59	
	M265065160	5.13	18.91	16.29	8.95	25.19	21.32	18.66	
	M265065180	5.76	22.77	19.60	9.95	30.25	25.61	20.76	
	M265065200	6.43	26.32	22.47	10.93	34.90	29.32	22.78	
	M265065220	7.03	29.77	25.60	11.88	39.39	33.36	24.77	
	M265065250	8.03	35.30	29.89	13.24	46.64	38.90	27.60	
M265065270	8.70	38.60	32.66	14.11	50.95	42.47	29.42		

Table 1:16 Single Span

Span (m)	Section	Self Weight kg/m	Gravity kN	External Bay Uplift kN			Defl Limit L/180 kN	Internal Bay Uplift kN				Defl Limit L/180 kN
				No	One	Two		Gravity kN	No	One	Two	
6.0	M175065120	3.02	12.52	12.52	12.52	12.52	8.69	16.41	16.41	16.41	16.41	18.11
	M175065130	3.29	14.67	14.67	14.67	14.67	9.37	19.22	19.22	19.22	19.22	19.54
	M175065140	3.52	16.90	16.90	16.90	16.90	10.05	22.12	22.12	22.12	22.12	20.95
	M175065150	3.79	19.15	19.15	19.15	19.15	10.71	25.06	25.06	25.06	25.06	22.33
	M175065160	4.05	21.42	21.42	21.42	21.42	11.37	28.01	28.01	28.01	28.01	23.69
	M175065180	4.55	25.88	25.88	25.88	25.88	12.65	33.82	33.82	33.82	33.82	26.37
	M175065200	5.08	30.13	30.13	30.13	30.13	13.89	39.36	39.36	39.36	39.36	28.96
	M175065220	5.56	34.18	34.18	34.18	34.18	15.11	44.64	44.64	44.64	44.64	31.49
	M175065250	6.35	39.96	39.96	39.96	39.96	16.85	52.17	52.17	52.17	52.17	35.13
	M205065120	3.29	15.30	15.30	15.30	15.30	12.57	19.65	19.65	19.65	19.65	26.20
	M205065130	3.58	17.96	17.96	17.96	17.96	13.56	23.11	23.11	23.11	23.11	28.26
	M205065140	3.84	20.70	20.70	20.70	20.70	14.53	26.67	26.67	26.67	26.67	30.30
	M205065150	4.13	23.48	23.48	23.48	23.48	15.49	30.28	30.28	30.28	30.28	32.30
	M205065160	4.41	26.27	26.27	26.27	26.27	16.44	33.91	33.91	33.91	33.91	34.26
	M205065170	4.67	29.05	29.05	29.05	29.05	17.39	37.53	37.53	37.53	37.53	36.26
	M205065180	4.96	31.78	31.78	31.78	31.78	18.29	41.08	41.08	41.08	41.08	38.13
	M205065200	5.53	37.05	37.05	37.05	37.05	20.09	47.94	47.94	47.94	47.94	41.87
	M205065220	6.05	42.08	42.08	42.08	42.08	21.84	54.50	54.50	54.50	54.50	45.53
	M205065250	6.91	49.31	49.31	49.31	49.31	24.36	63.91	63.91	63.91	63.91	50.78
	M205065270	7.49	53.95	53.95	53.95	53.95	25.97	69.96	69.96	69.96	69.96	54.14
	M235065130	3.86	21.35	18.56	21.35	21.35	18.69	26.96	23.43	26.96	26.96	38.95
	M235065140	4.14	24.65	21.38	24.65	24.65	20.03	31.22	27.09	31.22	31.22	41.76
	M235065150	4.45	27.98	24.19	27.98	27.98	21.35	35.55	30.74	35.55	35.55	44.51
	M235065160	4.76	31.33	27.08	31.33	31.33	22.65	39.90	34.49	39.90	39.90	47.22
	M235065170	5.04	34.67	29.87	34.67	34.67	23.93	44.23	38.12	44.23	44.23	49.89
	M235065180	5.35	37.95	32.68	37.95	37.95	25.20	48.50	41.77	48.50	48.50	52.54
M235065200	5.97	44.31	38.13	44.31	44.31	27.67	56.78	48.86	56.78	56.78	57.68	
M235065220	6.53	50.41	45.55	50.41	50.41	30.09	64.72	58.48	64.72	64.72	62.72	
M235065250	7.46	59.17	53.40	59.17	59.17	33.55	76.14	68.71	76.14	76.14	69.93	
M235065270	8.08	64.84	58.51	64.84	64.84	35.76	83.53	75.37	83.53	83.53	74.55	
6.5	M175065120	3.02	11.65	11.65	11.65	11.65	7.40	15.42	15.42	15.42	15.42	15.43
	M175065130	3.29	13.64	13.64	13.64	13.64	7.99	18.02	18.02	18.02	18.02	16.65
	M175065140	3.52	15.69	15.69	15.69	15.69	8.56	20.70	20.70	20.70	20.70	17.85
	M175065150	3.79	17.77	17.77	17.77	17.77	9.13	23.41	23.41	23.41	23.41	19.03
	M175065160	4.05	19.86	19.86	19.86	19.86	9.68	26.14	26.14	26.14	26.14	20.19
	M175065180	4.55	23.98	23.98	23.98	23.98	10.78	31.51	31.51	31.51	31.51	22.47
	M175065200	5.08	27.90	27.90	27.90	27.90	11.84	36.61	36.61	36.61	36.61	24.68
	M175065220	5.56	31.64	31.64	31.64	31.64	12.87	41.48	41.48	41.48	41.48	26.83
	M175065250	6.35	36.95	36.95	36.95	36.95	14.36	48.41	48.41	48.41	48.41	29.93
	M205065120	3.29	14.28	14.28	14.28	14.28	10.71	18.55	18.55	18.55	18.55	22.33
	M205065130	3.58	16.74	16.74	16.74	16.74	11.55	21.76	21.76	21.76	21.76	24.08
	M205065140	3.84	19.27	19.27	19.27	19.27	12.38	25.04	25.04	25.04	25.04	25.82
	M205065150	4.13	21.83	21.83	21.83	21.83	13.20	28.39	28.39	28.39	28.39	27.52
	M205065160	4.41	24.41	24.41	24.41	24.41	14.00	31.73	31.73	31.73	31.73	29.19
	M205065170	4.67	26.98	26.98	26.98	26.98	14.82	35.08	35.08	35.08	35.08	30.89
	M205065180	4.96	29.49	29.49	29.49	29.49	15.58	38.35	38.35	38.35	38.35	32.49
	M205065200	5.53	34.35	34.33	34.35	34.35	17.12	44.68	44.66	44.68	44.68	35.68
	M205065220	6.05	38.99	38.45	38.99	38.99	18.61	50.73	50.02	50.73	50.73	38.80
	M205065250	6.91	45.64	44.25	45.64	45.64	20.76	59.40	57.59	59.40	59.40	43.27
	M205065270	7.49	49.92	47.94	49.92	49.92	22.13	64.97	62.40	64.97	64.97	46.13
	M235065130	3.86	19.95	13.72	19.95	19.95	15.92	25.49	17.52	25.49	25.49	33.19
	M235065140	4.14	22.99	15.81	22.99	22.99	17.07	29.43	20.24	29.43	29.43	35.59
	M235065150	4.45	26.07	17.89	26.07	26.07	18.19	33.44	22.95	33.44	33.44	37.93
	M235065160	4.76	29.16	20.05	29.16	29.16	19.30	37.45	25.75	37.45	37.45	40.23
	M235065170	5.04	32.24	22.13	32.24	32.24	20.39	41.46	28.45	41.46	41.46	42.51
	M235065180	5.35	35.27	24.22	35.27	35.27	21.47	45.40	31.17	45.40	45.40	44.77
M235065200	5.97	41.13	28.29	41.13	41.13	23.58	53.03	36.47	53.03	53.03	49.15	
M235065220	6.53	46.75	34.02	46.75	46.75	25.64	60.35	43.92	60.35	60.35	53.44	
M235065250	7.46	54.83	39.98	54.83	54.83	28.58	70.88	51.69	70.88	70.88	59.58	
M235065270	8.08	60.05	43.88	60.05	60.05	30.47	77.68	56.76	77.68	77.68	63.52	

Multibeam Purlins - Load Tables

Multibeam Purlins Continuous System

Table 1:16 Single Span (Cont.)

Span (m)	Section	Self Weight kg/m	Gravity kN	External Bay Uplift kN			Defl Limit L/180 kN	Gravity kN	Internal Bay Uplift kN			Defl Limit L/180 kN
				No	One	Two			No	One	Two	
7.0	M175065120	3.02	10.89	9.20	10.89	10.89	6.38	14.53	12.28	14.53	14.53	13.31
	M175065130	3.29	12.73	10.72	12.73	12.73	6.88	16.95	14.27	16.95	16.95	14.35
	M175065140	3.52	14.64	12.29	14.64	14.64	7.38	19.44	16.31	19.44	19.44	15.39
	M175065150	3.79	16.57	13.90	16.57	16.57	7.87	21.96	18.41	21.96	21.96	16.41
	M175065160	4.05	18.51	15.49	18.51	18.51	8.35	24.49	20.50	24.49	24.49	17.41
	M175065180	4.55	22.32	18.66	22.32	22.32	9.29	29.47	24.63	29.47	29.47	19.37
	M175065200	5.08	25.96	21.63	25.96	25.96	10.21	34.21	28.50	34.21	34.21	21.28
	M175065220	5.56	29.42	24.51	29.42	29.42	11.10	38.72	32.26	38.72	38.72	23.14
	M175065250	6.35	34.35	28.60	34.35	34.35	12.38	45.14	37.58	45.14	45.14	25.81
	M205065120	3.29	13.38	11.28	13.38	13.38	9.23	17.55	14.81	17.55	17.55	19.25
	M205065130	3.58	15.66	13.15	15.66	15.66	9.96	20.52	17.23	20.52	20.52	20.76
	M205065140	3.84	18.01	15.11	18.01	18.01	10.68	23.59	19.78	23.59	23.59	22.26
	M205065150	4.13	20.39	17.05	20.39	20.39	11.38	26.69	22.31	26.69	26.69	23.73
	M205065160	4.41	22.78	19.02	22.78	22.78	12.08	29.80	24.89	29.80	29.80	25.17
	M205065170	4.67	25.17	20.66	25.17	25.17	12.78	32.91	27.03	32.91	32.91	26.64
	M205065180	4.96	27.49	22.90	27.49	27.49	13.44	35.95	29.94	35.95	35.95	28.01
	M205065200	5.53	32.00	26.05	32.00	32.00	14.76	41.82	34.05	41.82	41.82	30.76
	M205065220	6.05	36.30	29.21	36.30	36.30	16.05	47.43	38.17	47.43	47.43	33.45
	M205065250	6.91	42.46	33.71	42.46	42.46	17.90	55.46	44.02	55.46	55.46	37.31
	M235065270	7.49	46.42	36.56	46.42	46.42	19.08	60.63	47.74	60.63	60.63	39.77
	M235065130	3.86	18.70	10.35	18.70	18.70	13.73	24.14	13.35	20.20	24.14	28.62
	M235065140	4.14	21.53	11.92	21.53	21.53	14.72	27.81	15.40	23.18	27.81	30.68
	M235065150	4.45	24.39	13.50	24.39	24.39	15.69	31.53	17.45	26.26	31.53	32.70
	M235065160	4.76	27.26	15.13	27.26	27.26	16.64	35.26	19.57	29.67	35.26	34.69
M235065170	5.04	30.11	16.70	30.11	30.11	17.58	38.98	21.62	32.35	38.98	36.65	
M235065180	5.35	32.92	18.28	32.92	32.92	18.52	42.64	23.68	35.38	42.64	38.60	
M235065200	5.97	38.36	21.37	38.36	38.36	20.33	49.72	27.71	41.19	49.72	42.38	
M235065220	6.53	43.58	25.79	43.58	43.58	22.10	56.51	33.45	49.29	56.51	46.08	
M235065250	7.46	51.06	30.37	51.06	51.06	24.65	66.26	39.41	57.77	66.26	51.38	
M235065270	8.08	55.90	33.36	55.90	55.90	26.27	72.58	43.32	63.24	72.58	54.77	
7.5	M175065120	3.02	10.21	7.07	10.21	10.21	5.56	13.73	9.50	13.73	13.73	11.59
	M175065130	3.29	11.93	8.24	11.93	11.93	6.00	15.98	11.04	15.98	15.98	12.50
	M175065140	3.52	13.71	9.46	13.71	13.71	6.43	18.31	12.62	18.31	18.31	13.41
	M175065150	3.79	15.51	10.70	15.51	15.51	6.86	20.66	14.26	20.66	20.66	14.29
	M175065160	4.05	17.32	11.94	17.32	17.32	7.27	23.03	15.88	23.03	23.03	15.16
	M175065180	4.55	20.87	14.40	20.87	20.87	8.10	27.67	19.09	27.67	27.67	16.88
	M175065200	5.08	24.26	16.73	24.26	24.26	8.89	32.09	22.12	32.09	32.09	18.54
	M175065220	5.56	27.48	18.98	27.48	27.48	9.67	36.29	25.05	36.29	36.29	20.16
	M175065250	6.35	32.07	22.18	32.07	32.07	10.78	42.27	29.23	42.27	42.27	22.48
	M205065120	3.29	12.57	8.66	12.57	12.57	8.04	16.64	11.47	16.64	16.64	16.77
	M205065130	3.58	14.70	10.10	14.70	14.70	8.68	19.19	13.34	19.41	19.41	18.09
	M205065140	3.84	16.89	11.62	16.89	16.89	9.30	22.28	15.32	22.28	22.28	19.39
	M205065150	4.13	19.11	13.12	19.11	19.11	9.91	25.17	17.27	25.17	25.17	20.67
	M205065160	4.41	21.34	14.65	21.34	21.34	10.52	28.07	19.28	28.07	28.07	21.93
	M205065170	4.67	23.57	15.92	23.57	23.57	11.13	30.98	20.93	30.98	30.98	23.21
	M205065180	4.96	25.73	17.59	25.73	25.73	11.70	33.81	23.11	33.81	33.81	24.40
	M205065200	5.53	29.93	20.02	29.93	29.93	12.86	39.29	26.27	39.29	39.29	26.80
	M205065220	6.05	33.95	22.47	33.95	33.95	13.98	44.51	29.47	44.51	44.51	29.14
	M205065250	6.91	39.68	25.97	39.68	39.68	15.59	52.00	34.04	52.00	52.00	32.50
	M205065270	7.49	43.37	28.21	43.37	43.37	16.62	56.81	36.95	56.81	56.81	34.65
	M235065130	3.86	17.60	7.96	17.60	17.60	11.96	22.90	10.36	22.90	22.90	24.93
	M235065140	4.14	20.23	9.17	20.23	20.23	12.82	26.33	11.93	26.33	26.33	26.73
	M235065150	4.45	22.89	10.38	22.89	22.89	13.66	29.80	13.52	29.80	29.80	28.49
	M235065160	4.76	25.57	11.63	25.57	25.57	14.50	33.29	15.14	33.29	33.29	30.22
M235065170	5.04	28.24	12.84	28.24	28.24	15.32	36.76	16.72	36.76	36.76	31.93	
M235065180	5.35	30.86	14.06	30.86	30.86	16.13	40.18	18.31	40.18	40.18	33.62	
M235065200	5.97	35.93	16.45	35.93	35.93	17.71	46.78	21.41	46.78	46.78	36.92	
M235065220	6.53	40.78	19.86	40.78	40.78	19.26	53.11	25.86	53.11	53.11	40.14	
M235065250	7.46	47.75	23.41	47.75	47.75	21.47	62.20	30.50	62.20	62.20	44.76	
M235065270	8.08	52.25	25.75	52.25	52.25	22.89	68.07	33.54	68.07	68.07	47.71	

Span (m)	Section	Self Weight kg/m	Gravity kN	External Bay Uplift kN			Defl Limit L/180 kN	Gravity kN	Internal Bay Uplift kN			Defl Limit L/180 kN
				No	One	Two			No	One	Two	
8.0	M175065120	3.02	9.60	-	9.03	9.60	4.89	12.99	-	12.22	12.99	10.19
	M175065130	3.29	11.22	-	10.48	11.22	5.27	15.10	-	14.12	15.10	10.99
	M175065140	3.52	12.88	-	11.95	12.88	5.65	17.29	-	16.04	17.29	11.78
	M175065150	3.79	14.57	-	13.46	14.57	6.03	19.50	-	18.02	19.50	12.56
	M175065160	4.05	16.26	-	14.98	16.26	6.39	21.71	-	20.01	21.71	13.33
	M175065180	4.55	19.58	-	17.91	19.58	7.12	26.06	-	23.83	26.06	14.83
	M175065200	5.08	23.07	-	20.76	23.07	7.82	30.19	-	27.54	30.19	16.29
	M175065220	5.56	25.77	-	23.42	25.77	8.50	34.13	-	31.02	34.13	17.71
	M175065250	6.35	30.06	-	27.24	30.06	9.48	39.73	-	36.00	39.73	19.76
	M205065120	3.29	11.85	-	10.93	11.85	7.07	15.79	-	14.57	15.79	14.74
	M205065130	3.58	13.84	-	12.70	13.84	7.63	18.40	-	16.87	18.40	15.89
	M205065140	3.84	15.90	-	14.50	15.90	8.18	21.08	-	19.24	21.08	17.04
	M205065150	4.13	17.98	-	16.34	17.98	8.71	23.80	-	21.64	23.80	18.17
	M205065160	4.41	20.06	-	18.19	20.06	9.25	26.52	-	24.05	26.52	19.27
	M205065170	4.67	22.14	-	19.75	22.14	9.78	29.24	-	26.09	29.24	20.39
	M205065180	4.96	24.18	-	21.69	24.18	10.29	31.90	-	28.61	31.90	21.45
	M205065200	5.53	28.10	-	24.63	28.10	11.30	37.02	-	32.45	37.02	23.55
	M205065220	6.05	31.86	-	27.62	31.86	12.29	41.91	-	36.34	41.91	25.61
	M205065250	6.91	37.22	-	31.84	37.22	13.70	48.92	-	41.83	48.92	28.56
	M205065270	7.49	40.68	-	34.52	40.68	14.61	53.42	-	45.34	53.42	30.45
	M235065130	3.86	16.59	-	15.14	16.59	10.51	21.76	-	19.86	21.76	21.91
	M235065140	4.14	19.06	-	17.30	19.06	11.27	24.98	-	22.68	24.98	23.49
	M235065150	4.45	21.56	-	19.51	21.56	12.01	28.24	-	25.55	28.24	25.04
	M235065160	4.76	24.06	-	22.37	24.06	12.74	31.50	-	29.28	31.50	26.56
M235065170	5.04	26.56	-	23.95	26.56	13.46	34.76	-	31.34	34.76	28.06	
M235065180	5.35	29.02	-	26.38	29.02	14.18	37.96	-	34.50	37.96	29.55	
M235065200	5.97	33.76	-	30.29	33.76	15.56	44.14	-	39.61	44.14	32.45	
M235065220	6.53	38.30	-	36.07	38.30	16.92	50.07	-	47.15	50.07	35.28	
M235065250	7.46	44.82	-	42.09	44.82	18.87	58.58	-	55.00	58.58	39.34	
M235065270	8.08	49.04	-	46.00	49.04	20.11	64.07	-	60.10	64.07	41.93	
8.5	M205065120	3.29	11.19	-	11.19	11.19	6.26	15.02	-	15.02	15.02	13.05
	M205065130	3.58	13.07	-	10.07	13.07	6.75	17.48	-	13.46	17.48	14.08
	M205065140	3.84	15.00	-	11.52	15.00	7.24	20.00	-	15.36	20.00	15.10
	M205065150	4.13	16.96	-	12.99	16.96	7.72	22.56	-	17.28	22.56	16.09
	M205065160	4.41	18.91	-	14.47	18.91	8.19	25.12	-	19.21	25.12	17.07
	M205065170	4.67	20.88	-	15.71	20.88	8.67	27.68	-	20.83	27.68	18.06
	M205065180	4.96	22.79	-	17.22	22.79	9.11	30.18	-	22.81	30.18	19.00
	M205065200	5.53	26.48	-	19.59	26.28	10.01	34.99	-	25.90	34.74	20.86
	M205065220	6.05	30.00	-	22.00	29.44	10.88	39.59	-	29.04	38.85	22.69
	M205065250	6.91	35.04	-	25.41	33.90	12.14	46.16	-	33.47	44.66	25.30
	M205065270	7.49	38.28	-	27.58	36.73	12.94	50.39	-	36.31	48.36	26.97
	M235065130	3.86	15.69	-	12.00	15.69	9.31	20.71	-	15.84	20.71	19.41
	M235065140	4.14	18.01	-	13.73	18.01	9.98	23.75	-	18.10	23.75	20.81
	M235065150	4.45	20.37	-	15.49	20.37	10.64	26.82	-	20.39	26.82	22.18
	M235065160	4.76	22.72	-	17.80	22.72	11.29	29.89	-	23.42	29.89	23.53
	M235065170	5.04	25.07	-	19.04	25.07	11.92	32.95	-	25.03	32.95	24.86
	M235065180	5.35	27.37	-	21.00	27.37	12.56	35.96	-	27.59	35.96	26.18
	M235065200	5.97	31.83	-	24.13	31.83	13.79	41.78	-	31.67	41.78	28.74
	M235065220	6.53	36.10	-	28.93	36.10	14.99	47.35	-	37.94	47.35	31.25
	M235065250	7.46	42.22	-	33.84	42.22	16.72	55.34	-	44.34	55.34	34.84
	M235065270	8.08	46.18	-	37.03	46.18	17.82	60.49	-	48.51	60.49	37.14
	M265065140	4.46	21.16	-	16.02	21.16	13.26	27.57	-	20.88	27.57	27.64
	M265065150	4.79	23.93	-	17.91	23.93	14.13	31.19	-	23.34	31.19	29.46
	M265065160	5.13	26.71	-	20.20	26.71	14.99	34.81	-	26.32	34.81	31.24
M265065180	5.76	32.19	-	24.40	32.19	16.67	41.96	-	31.81	41.96	34.76	
M265065200	6.43	37.46	-	28.11	37.46	18.30	48.83	-	36.64	48.83	38.15	
M265065220	7.03	42.53	-	32.63	42.53	19.90	55.43	-	42.54	55.43	41.48	
M265065250	8.03	49.81	-	36.99	49.65	22.18	64.93	-	48.22	64.72	46.23	
M265065270	8.70	54.53	-	40.53	54.19	23.63	71.09	-	52.84	70.65	49.27	

Multibeam Purlins - Load Tables

Multibeam Purlins Continuous System

Table 1:16 Single Span (Cont.)

Span (m)	Section	Self Weight kg/m	Gravity kN	External Bay Uplift kN			Defl Limit L/180 kN	Gravity kN	Internal Bay Uplift kN			Defl Limit L/180 kN
				No	One	Two			No	One	Two	
9.0	M205065120	3.29	10.60	-	6.94	9.55	5.59	14.31	-	9.36	12.90	11.64
	M205065130	3.58	12.38	-	8.07	11.08	6.02	16.63	-	10.85	14.89	12.56
	M205065140	3.84	14.19	-	9.23	12.64	6.46	19.02	-	12.38	16.93	13.47
	M205065150	4.13	16.04	-	10.42	14.22	6.88	21.43	-	13.92	19.01	14.35
	M205065160	4.41	17.88	-	11.62	15.82	7.30	23.85	-	15.49	21.10	15.23
	M205065170	4.67	19.73	-	12.62	17.15	7.73	26.26	-	16.79	22.83	16.11
	M205065180	4.96	21.54	-	13.82	18.74	8.13	28.62	-	18.36	24.90	16.95
	M205065200	5.53	25.01	-	15.73	21.29	8.93	33.17	-	20.86	28.22	18.61
	M205065220	6.05	28.33	-	17.69	23.88	9.71	37.49	-	23.40	31.59	20.24
	M205065250	6.91	33.08	-	20.46	27.54	10.83	43.70	-	27.02	36.38	22.57
	M205065270	7.49	36.14	-	22.23	29.88	11.54	47.67	-	29.33	39.43	24.06
	M235065130	3.86	14.88	-	9.61	13.22	8.31	19.76	-	12.77	17.56	17.31
	M235065140	4.14	17.06	-	11.01	15.10	8.90	22.62	-	14.58	20.02	18.56
	M235065150	4.45	19.28	-	12.42	17.01	9.49	25.52	-	16.43	22.51	19.78
	M235065160	4.76	21.50	-	14.30	19.63	10.07	28.42	-	18.90	25.95	20.99
	M235065170	5.04	23.72	-	15.29	20.81	10.64	31.31	-	20.19	27.48	22.17
	M235065180	5.35	25.89	-	16.88	23.08	11.20	34.15	-	22.27	30.44	23.35
	M235065200	5.97	30.10	-	19.41	26.30	12.30	39.64	-	25.57	34.64	25.64
	M235065220	6.53	34.12	-	23.38	31.33	13.37	44.88	-	30.76	41.21	27.88
	M235065250	7.46	39.89	-	27.41	36.55	14.91	52.42	-	36.01	48.02	31.08
	M235065270	8.08	43.61	-	30.02	39.91	15.89	57.28	-	39.43	52.42	33.13
	M265065140	4.46	20.06	-	12.84	17.68	11.83	26.31	-	16.84	23.18	24.66
	M265065150	4.79	22.68	-	14.36	19.69	12.60	29.72	-	18.82	25.80	26.27
	M265065160	5.13	25.30	-	16.20	22.14	13.37	33.14	-	21.22	29.01	27.87
	M265065180	5.76	30.47	-	19.60	26.78	14.87	39.89	-	25.65	35.06	31.00
	M265065200	6.43	35.45	-	22.59	30.67	16.32	46.38	-	29.56	40.13	34.03
	M265065220	7.03	40.22	-	26.28	35.51	17.75	52.61	-	34.37	46.44	37.00
	M265065250	8.03	47.09	-	29.78	40.22	19.78	61.56	-	38.94	52.59	41.24
	M265065270	8.70	51.53	-	32.54	43.95	21.08	67.36	-	42.53	57.45	43.95

Span (m)	Section	Self Weight kg/m	Gravity kN	External Uplift kN		Defl Limit L/180 kN	Internal Uplift kN		Defl Limit L/180 kN
				Three Restraints	Three Restraints		Gravity kN	Three Restraints	
9.5	M205065130	3.58	11.73	10.10	5.41	15.86	13.40	11.27	
	M205065140	3.84	13.46	11.52	5.80	18.12	15.25	12.09	
	M205065150	4.13	15.20	12.98	6.18	20.40	17.14	12.88	
	M205065160	4.41	16.95	14.43	6.56	22.69	19.02	13.67	
	M205065170	4.67	18.70	15.88	6.94	24.98	20.90	14.46	
	M205065180	4.96	20.41	17.30	7.30	27.20	22.74	15.21	
	M205065200	5.53	23.69	20.05	8.01	31.50	26.30	16.70	
	M205065220	6.05	26.83	22.66	8.71	35.60	29.68	18.16	
	M205065250	6.91	31.31	26.42	9.72	41.46	34.53	20.25	
	M205065270	7.49	34.20	28.84	10.36	45.22	37.66	21.59	
	M235065130	3.86	14.13	12.07	7.46	18.87	15.86	15.54	
	M235065140	4.14	16.20	13.78	7.99	21.58	18.09	16.66	
	M235065150	4.45	18.30	15.52	8.52	24.32	20.34	17.76	
	M235065160	4.76	20.41	17.26	9.03	27.08	22.60	18.83	
	M235065170	5.04	22.50	18.99	9.55	29.81	24.84	19.90	
	M235065180	5.35	24.56	20.70	10.05	32.50	27.06	20.96	
	M235065200	5.97	28.53	24.01	11.04	37.69	31.33	23.01	
	M235065220	6.53	32.33	27.15	12.00	42.66	35.42	25.02	
	M235065250	7.46	37.78	31.70	13.38	49.77	41.29	27.89	
	M235065270	8.08	41.31	34.65	14.26	54.37	45.10	29.74	
	M265065140	4.46	19.07	16.14	10.61	25.15	21.00	22.13	
	M265065150	4.79	21.55	18.18	11.31	28.38	23.65	23.58	
	M265065160	5.13	24.03	20.24	12.00	31.62	26.31	25.01	
	M265065180	5.76	28.92	24.27	13.35	38.01	31.54	27.83	
	M265065200	6.43	33.62	28.17	14.65	44.15	36.58	30.54	
	M265065220	7.03	38.13	31.90	15.93	50.03	41.41	33.21	
	M265065250	8.03	44.63	37.29	17.75	58.50	48.39	37.01	
	M265065270	8.70	48.82	40.77	18.92	63.98	52.91	39.45	

Span (m)	Section	Self Weight		External Bay Uplift kN		Defl Limit L/180 kN	Internal Bay Uplift kN		Defl Limit L/180 kN
		kg/m	Gravity kN	Three Restrains	Three Restrains		Gravity kN	Three Restrains	
10.0	M235065130	3.86	13.44	11.56	6.73	18.05	15.24	14.02	
	M235065140	4.14	15.41	13.19	7.21	20.62	17.36	15.03	
	M235065150	4.45	17.40	14.85	7.69	23.23	19.51	16.02	
	M235065160	4.76	19.40	16.51	8.16	25.84	21.66	17.00	
	M235065170	5.04	21.38	18.16	8.61	28.44	23.80	17.96	
	M235065180	5.35	23.34	19.78	9.07	30.99	25.90	18.91	
	M235065200	5.97	27.10	22.92	9.96	35.91	29.97	20.77	
	M235065220	6.53	30.71	25.93	10.83	40.62	33.85	22.58	
	M235065250	7.46	35.88	30.25	12.08	47.37	39.45	25.18	
	M235065270	8.08	39.21	33.05	12.87	51.73	43.06	26.84	
	M265065140	4.46	18.16	15.46	9.58	24.07	20.18	19.97	
	M265065160	4.79	20.51	17.40	10.21	27.14	22.71	21.28	
	M265065180	5.13	22.86	19.36	10.83	30.21	25.23	22.58	
	M265065200	5.76	27.51	23.20	12.05	36.28	30.22	25.11	
	M265065220	6.43	31.97	26.91	13.22	42.10	35.02	27.56	
	M265065250	7.03	36.25	30.46	14.38	47.69	39.61	29.97	
	M265065270	8.03	42.40	35.59	16.02	55.72	46.24	33.40	
	M265065270	8.70	46.37	38.91	17.08	60.91	50.54	35.60	
	10.5	M235065130	3.86	12.82	11.10	6.10	17.28	14.67	12.72
		M235065140	4.14	14.69	12.65	6.54	19.74	16.70	13.64
M235065150		4.45	16.58	14.24	6.97	22.22	18.74	14.53	
M235065160		4.76	18.48	15.82	7.39	24.71	20.80	15.42	
M235065170		5.04	20.37	17.40	7.82	27.17	22.84	16.29	
M235065180		5.35	22.22	18.94	8.23	29.60	24.85	17.15	
M235065200		5.97	25.80	21.95	9.04	34.28	28.73	18.84	
M235065220		6.53	29.23	24.81	9.82	38.76	32.43	20.48	
M235065250		7.46	34.14	28.94	10.96	45.17	37.77	22.83	
M235065270		8.08	37.31	31.61	11.68	49.32	41.21	24.34	
M265065140		4.46	17.33	14.84	8.69	23.07	19.43	18.11	
M265065150		4.79	19.56	16.70	9.26	25.99	21.84	19.31	
M265065160		5.13	21.80	18.55	9.82	28.92	24.26	20.47	
M265065180		5.76	26.22	22.23	10.93	34.69	29.01	22.78	
M265065200		6.43	30.45	25.77	11.99	40.23	33.58	25.00	
M265065220		7.03	34.52	29.15	13.04	45.54	37.96	27.18	
M265065250		8.03	40.36	34.04	14.53	53.17	44.29	30.29	
M265065270		8.70	44.14	37.21	15.49	58.11	48.38	32.29	
11.0		M265065140	4.46	16.56	14.27	7.92	22.13	18.73	16.50
		M265065150	4.79	18.69	16.05	8.44	24.93	21.03	17.59
	M265065160	5.13	20.82	17.83	8.95	27.71	23.34	18.66	
	M265065180	5.76	25.03	21.34	9.95	33.22	27.90	20.76	
	M265065200	6.43	29.06	24.72	10.93	38.50	32.26	22.78	
	M265065220	7.03	32.93	27.96	11.88	43.56	36.45	24.77	
	M265065250	8.03	38.50	32.64	13.24	50.83	42.50	27.60	
	M265065270	8.70	42.10	35.67	14.11	55.53	46.41	29.42	



MULTIBEAM EVOLVED

Lighter | Stiffer | Stronger | Greener



E265/200



E265/150



E215/170



E185/140

Eaves Beams

Overview 50

Restraint Systems 51

Construction Details 52

Product Dimensions and References 56

Section Properties 59

Load Charts 60

Eaves Beam - Overview



Applications

- Intersection between roof and wall cladding
- Double, monopitch, mansard, curved or flat roof applications
- Roof Slopes from -6° to $+30^{\circ}$
- Internal or external gutter arrangements

Material Specification

Hot dip galvanised steel to BS EN 10326:2004 and BS EN 10143:1993 'specifications for continuously hot dip zinc/metal coated structural steel strip'.

The minimum grade of steel used is S390GD, with Z275 zinc coating, giving an average coating thickness of 0.02mm to each side. Other galvanised coatings may be available.

Please contact our Technical Department for advice.

Sustainability

The Multibeam system has been engineered to ensure maximum performance whilst minimising the material content.

Individual sections are packed together using low carbon mild steel, blued and waxed banding which is wholly recyclable. Identification of the bundles is by paper labels which are biodegradable and can be recycled.

Softwood bearers, used to support the bundles in transport are from managed woodland and are reusable.

Reuse

Steel does not lose its strength or stiffness over time so remains a viable product for reuse. Assembly joints between components can be easily dismantled at any time to facilitate reuse. Sections can be recut to length and reholed to suit a revised use.

Recycling

Steel is one of the world's most recycled materials with over 40% of 'new' steel made from recycled steel. Kingspan's suppliers encourage, promote and assist in the return of steel for recycling.



Certification

Kingspan Structural Products has developed a fully integrated management system which combines all the common elements of **ISO 9001 (Quality)**, **ISO 14001 (Environment)** and **OHSAS 18001 (Occupational Health and Safety)** into one system. This simple coherent business management system enables the organisation to successfully achieve its purpose and mission to ensure that quality; safety and the environment are considered in all aspects of the business process. Further information on these certifications can be found on our website www.kingspanstructural.co.uk.

Range

- Section heights are available in 185mm, 215mm and 265mm
- Top flange 85mm, bottom flange 93mm
- Gauges from 1.63mm to 2.45mm

For full product dimensions see page 56.

simplify your eaves beam design - use the toolkit design software.

Eaves Beam Restraint Systems

The system incorporates a full range of cleats, brackets and struts providing solutions for all eaves conditions. The economy and practicality of the Eaves Beam System complements the Multibeam Purlin, Rail and Multichannel Systems providing a complete cladding support system.

Bays up to 6.1m
Strut at mid span

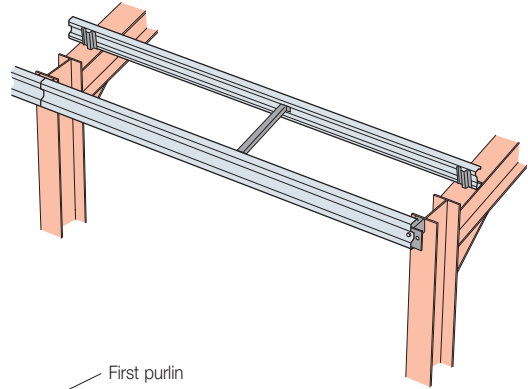

Bays over 6.1 - 9.5m
Strut at 1/3 points

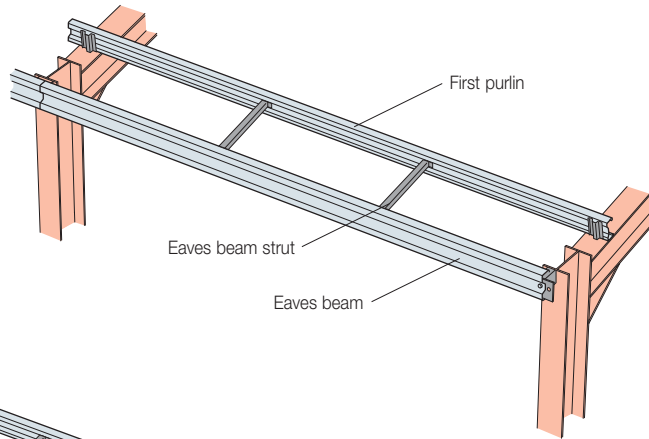

Bays over 9.5 - 12.0m
Strut at 1/4 points

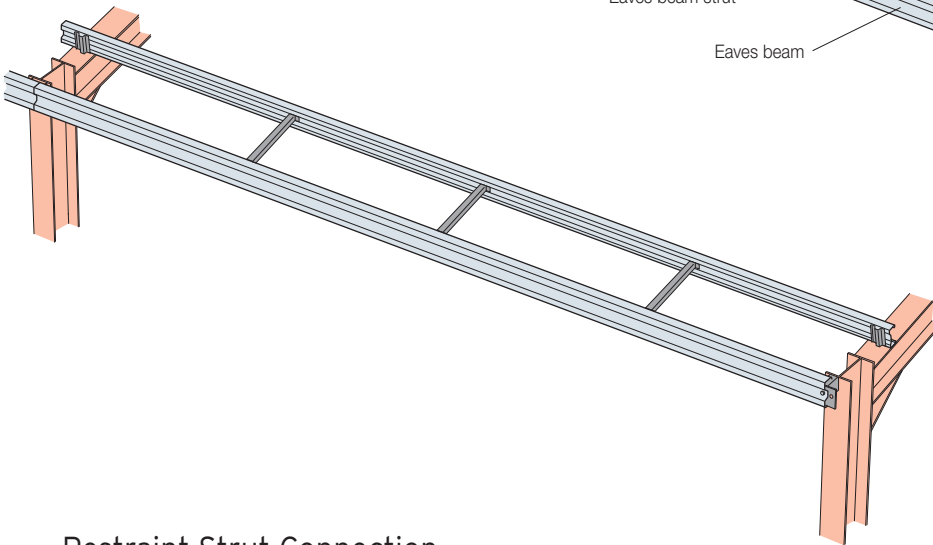

Restraint Strut Connection

Depending on the intended application there are several options available when connecting the strut from the eaves beam to the first purlin. For more detailed information see pages 52-55.

Construction Details - Eaves Beam

Connection to Main frame - Boundary Wall Gutter

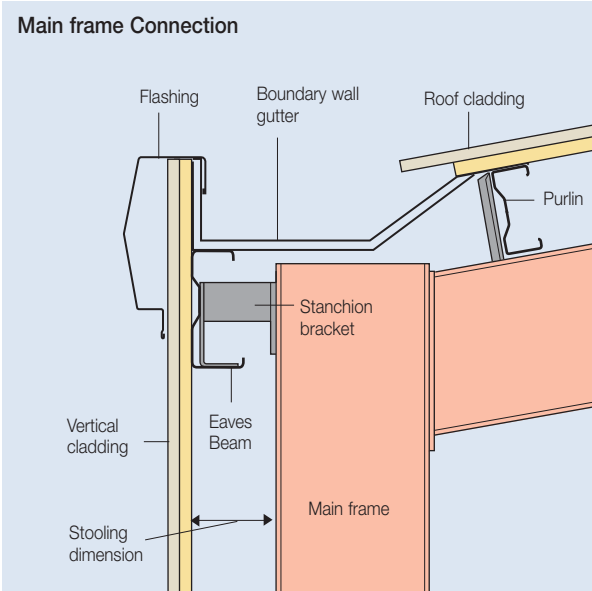

For product dimensions refer to pages 56-58.

Connection to Main frame - External Gutter

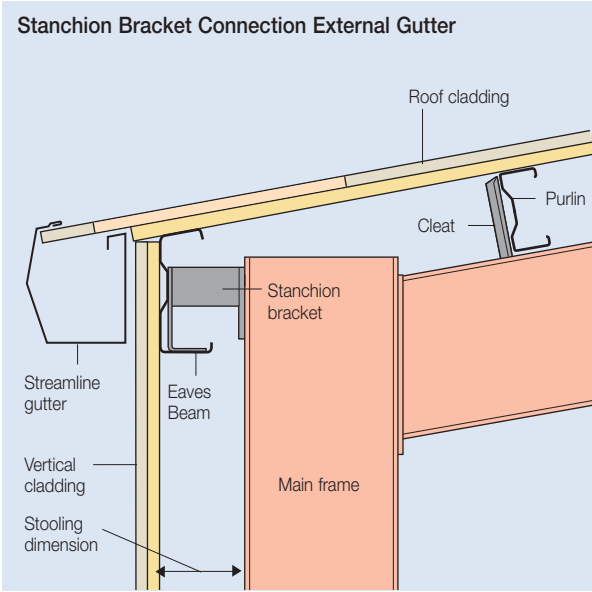

For product dimensions refer to pages 56-58.

Restraint Connection - Boundary Wall



For product dimensions refer to pages 56-58.

Strut Connection

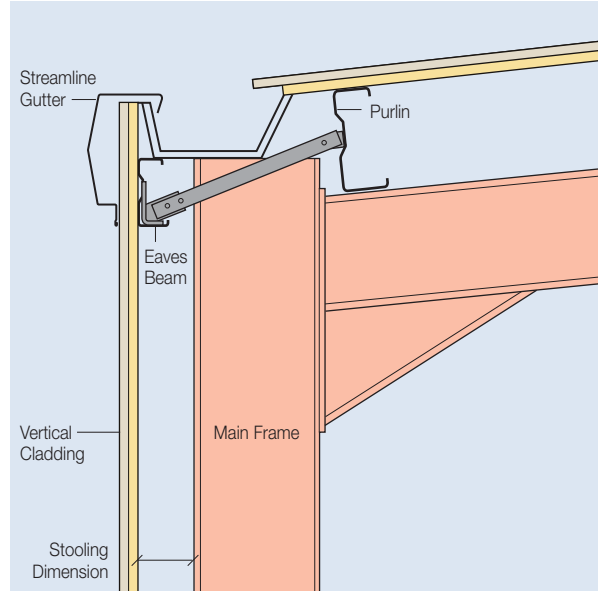

Boundary Wall

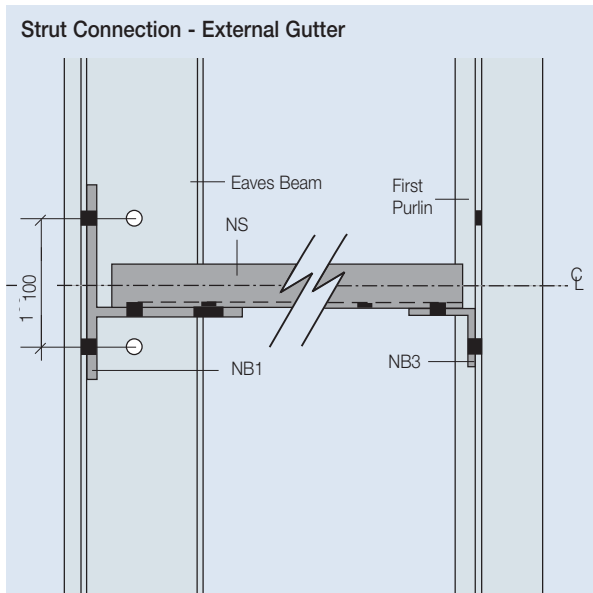

For product dimensions refer to pages 56-58.

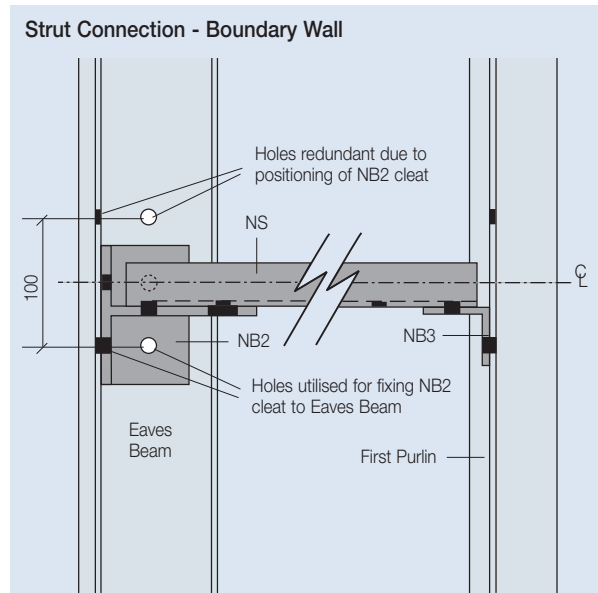

Construction Details - Eaves Beam



Restraint connection - External Gutter

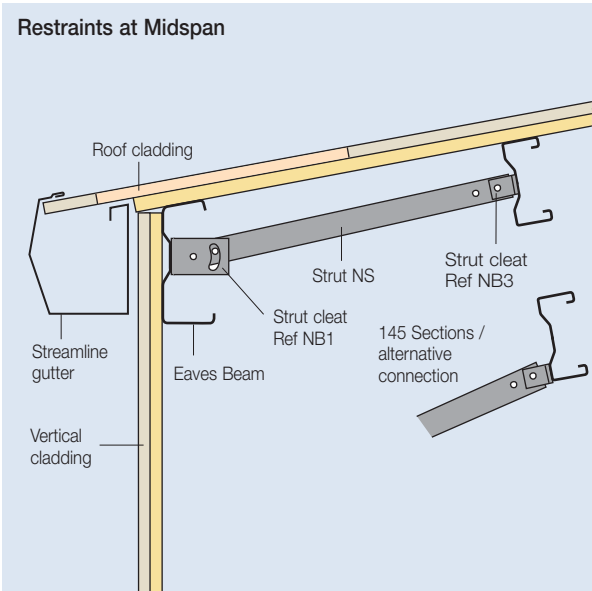

For product dimensions refer to pages 56-58.

Parapet

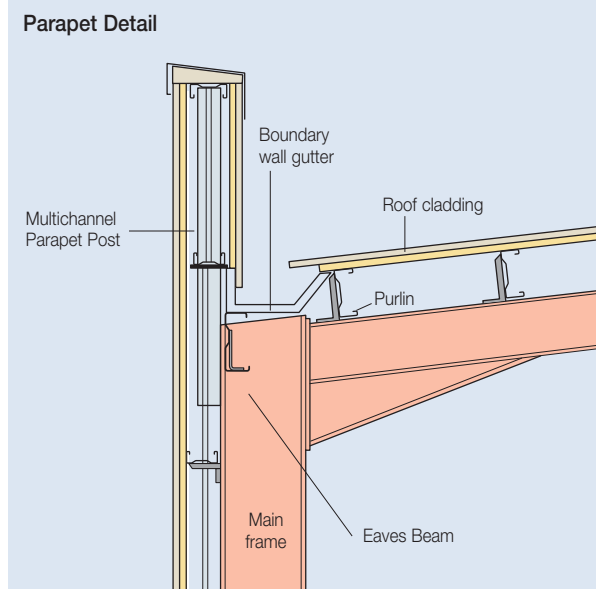
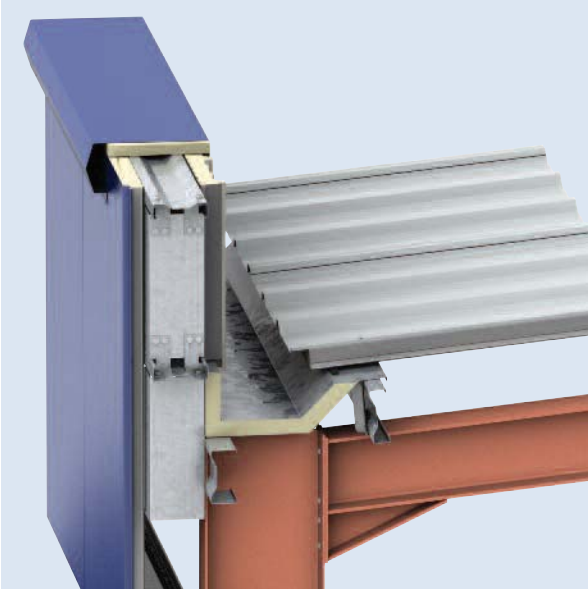

For product dimensions refer to pages 56-58.

Mono Pitch Roof - High Eaves

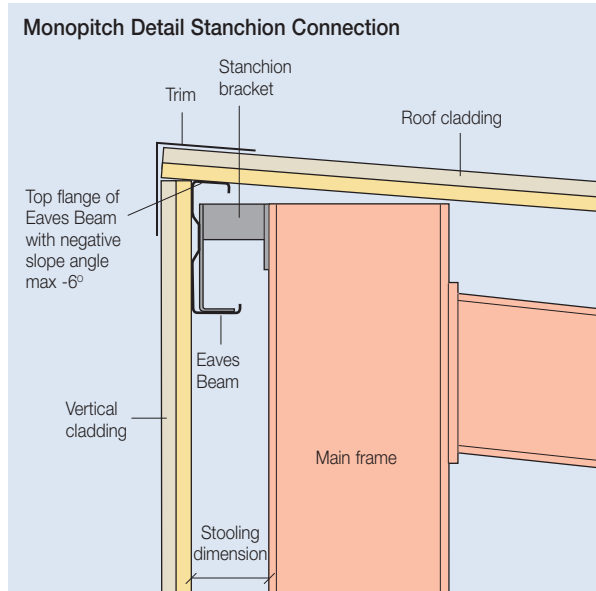
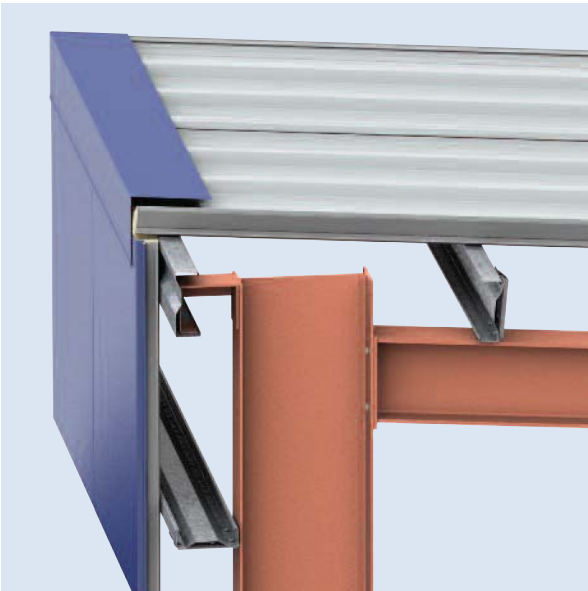

For product dimensions refer to pages 56-58.

Product Dimensions and References

Eaves Beam Sections

Stooling distance -
 The standard stanchion attachment bracket is engineered for a maximum stooling distance of 271mm (from outer face of stanchion to outer face of eaves beam). In order to match the maximum Multibeam side rail dimension. For dimensions greater than 271mm adopt a hot rolled stub or similar.

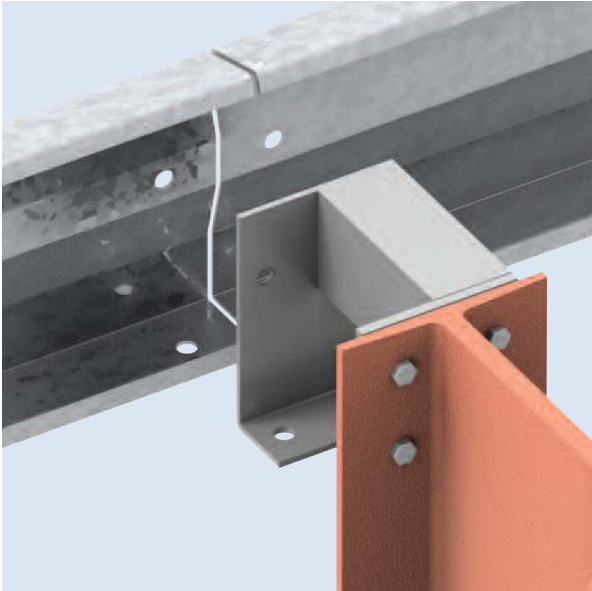
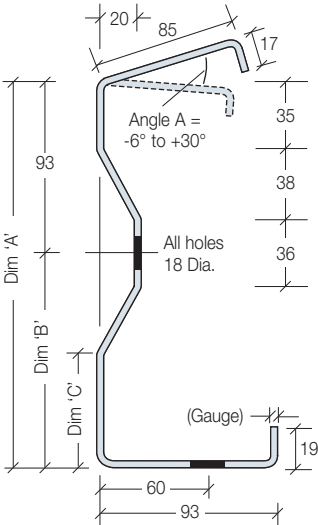

NB: Angle A available in 3° increments, please select nearest to your requirement.

Table 2:1 Eaves Beam Product Dimensions and References

References	Kg/M	Dims (mm)			Gauge (mm)
		A	B	C	
E185/140	5.00	185	92	38	1.63
E215/170	5.67	215	122	68	1.73
E265/150	6.37	265	172	118	1.73
E265/200	8.51	265	172	118	2.45



Eaves Beam Fixing Brackets

Table 2:2 Bolt-On Bracket

Multibeam Rail Size	Stooling Dim	E185	E215	E 265
145	151	NC185/151B	NC215/151B	NC265/151B
175	181	NC185/181B	NC215/181B	NC265/181B
205	211	NC185/211B	NC215/211B	NC265/211B
235	241	NC185/241B	NC215/241B	NC265/241B
265	271	NC185/271B	NC215/271B	NC265/271B
Non-Standard		NC185/dimB	NC215/dimB	NC265/dimB

Note: All Fixing Brackets are supplied in unpainted black steel as standard.

Table 2:3 Weld-On Bracket

Multibeam Rail Size	Stooling Dim	E185	E215	E 265
145	151	NC185/151	NC215/151	NC265/151
175	181	NC185/181	NC215/181	NC265/181
205	211	NC185/211	NC215/211	NC265/211
235	241	NC185/241	NC215/241	NC265/241
265	271	NC185/271	NC215/271	NC265/271
Non-Standard		NC185/dim	NC215/dim	NC265/dim

Table 2:4 Fixing Bracket Options

Options	Suffix	Example
Bolt-on cleat	BB	NC185/151BB
Bolt-on Painted	BE	NC185/151BE
Bolt-on Galvanised	BG	NC185/151BG

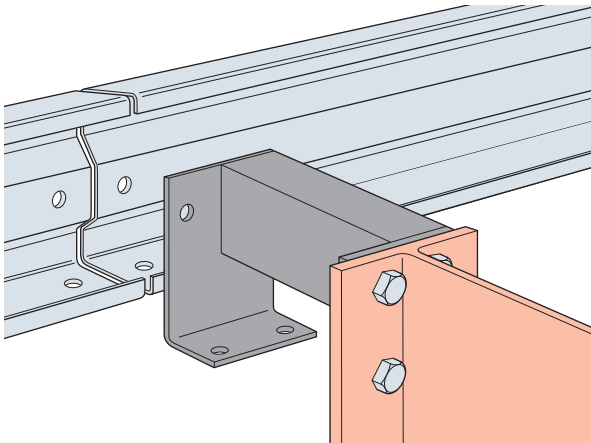

Stanchion connection bolt-on cleat

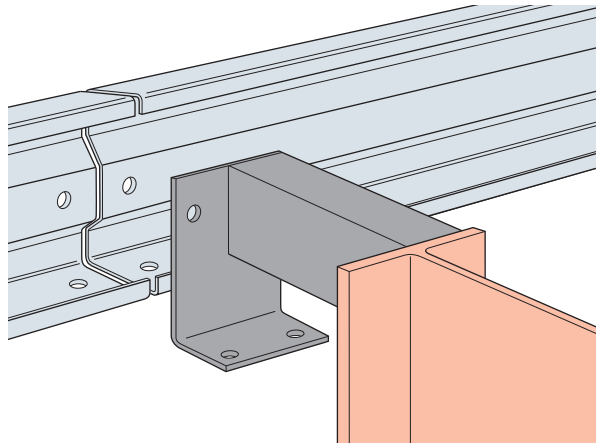

Stanchion connection weld-on cleat

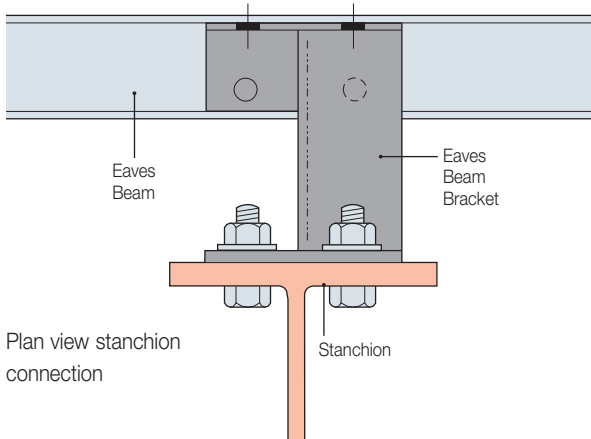

Plan view stanchion connection

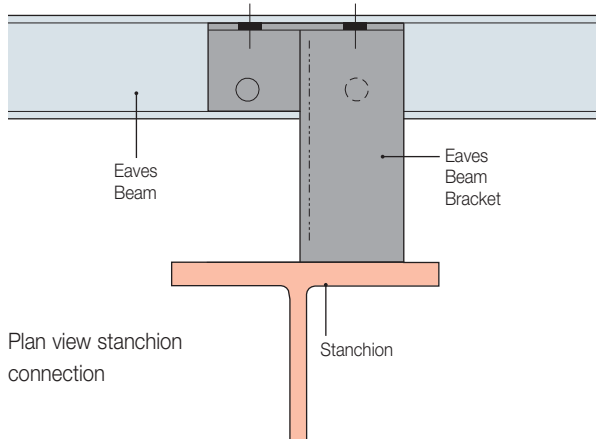

Plan view stanchion connection

Product Dimensions and References

Eaves Beam Strut Cleat

Part Reference

NB1

Cleat NB1 is for use where the roof cladding is fixed through to the top flange of the eaves beam and the gutter is an external cladding hung system.

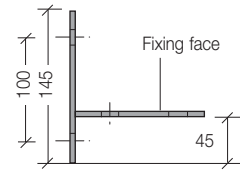
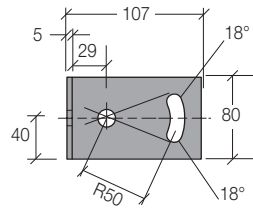

Max Roofslope 18°.
Hole dia 18mm connection to Eaves Beam
Hole dia 14mm connection to Eaves Strut

For design details see page 51. For construction details see pages 52-55.

Eaves Beam Strut Cleat

Part Reference

NB2 000 where 000 = section depth
eg; NB2 215

Cleat NB2 is for use where the roof cladding is not through fixed to the eaves beam i.e. Boundary wall gutter detail, Parapet detail, Clip fixed cladding.

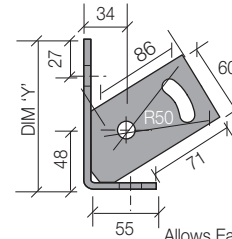
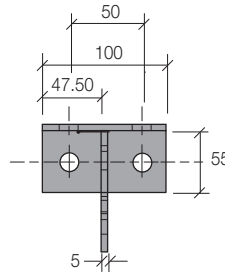

Allows Eaves Strut to be fixed, angle range 17° to 45°

For design details see page 51. For construction details see pages 52-55.

Eaves Beam Strut Cleat (Purlin bracket)

Part Reference

NB3

Used to attach the eaves strut to the purlin web.

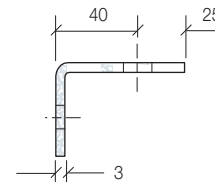
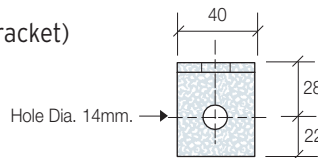

For design details see page 51. For construction details see pages 52-55.

Eaves Beam Strut

Part Reference

NS where 0000 = hole centres
eg; NS 2150

Used to brace the eaves beam against first purlin upslope.

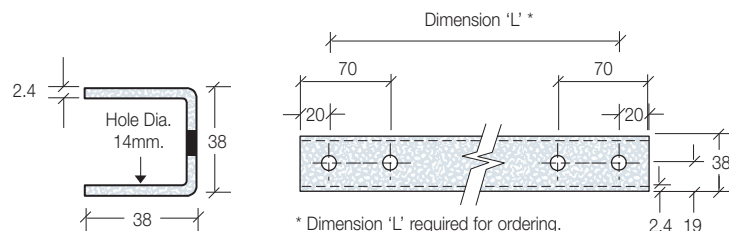

* Dimension 'L' required for ordering.

Standard finish galvanised steel

For design details see page 51. For construction details see pages 52-55.

Fixing Brackets

Part Reference Dim 'X' Dim 'Y'

NC185	90	158
NC215	120	188
NC265	170	238

* Standard stooling dimension = Multibeam rail depth + 6mm

All holes 18mm diameter

For design details see page 51.
For construction details see pages 52-55.

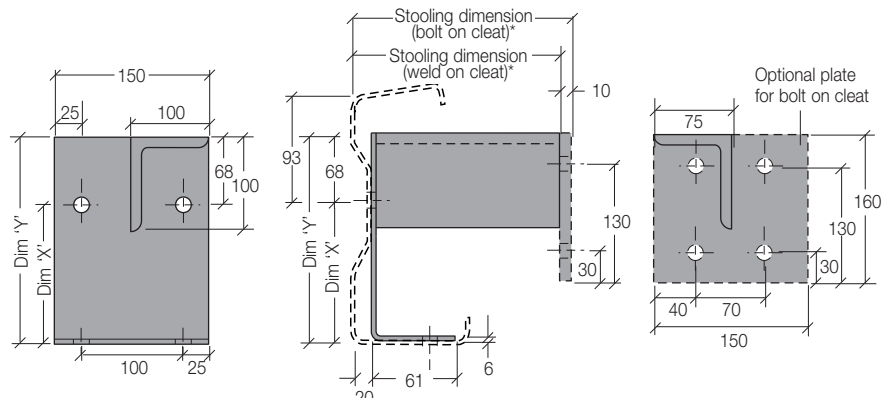

Eaves Beam Vertical Connection Cleat (EBC1)

Part Reference

EBC1

Gauge dimension 2.5mm.

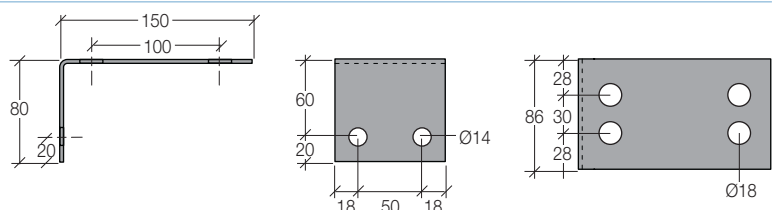

Eaves Beam - Section Properties

Load tables and charts - The interaction between vertical and horizontal loading is shown to allow the most efficient selection when using wind loading to BS6399 part 2. The values shown are ultimate values in kN and are based on the Eaves Beam being connected to the first purlin by the eaves strut(s) which restrains the eaves beam and transmits part of the horizontal wind loads through the diaphragm action of the roof.

Restraint struts are required on all spans see page 51

Design criteria are valid when the eaves beams are fitted exactly as shown in the Multibeam literature.

Spans up to 12m are possible, subject to minimum volumes - for further details contact our Technical Department.

Table 2:5 Eaves Beam Section Properties

Section Reference	Depth mm	Gauge mm	Weight kg/m	Area cm ²	Ixx cm ⁴	Zxx cm ³	Iyy cm ⁴	Zyy cm ³	Rxx cm	Ryy cm
E185140	185	1.63	5.00	6.39	356.59	37.34	58.32	9.31	7.47	3.02
E215170	215	1.73	5.67	7.24	512.28	47.2	66.04	10.22	8.41	3.02
E265150	265	1.73	6.37	8.08	835.55	62.7	72.5	10.71	10.17	3
E265200	265	2.45	8.51	11.53	1191.52	89.18	103.39	15.2	10.17	3

Eaves Beam - Capacities

Table 2:6 Eaves beam load table

Section Span m	E185140		E215170		E265150		E265200	
	Ult. Load kN	Gauge 1.63 defl. Limit	Ult. Load kN	Gauge 1.73 defl. Limit	Ult. Load kN	Gauge 1.73 defl. Limit	Ult. Load kN	Gauge 2.45 defl. Limit
3	31.822	34.655						
3.5	27.276	25.461						
4	23.866	19.494	30.135	28.005	37.528	45.677		
4.5	21.215	15.402	26.786	22.127	33.358	39.09		
5	19.093	12.476	24.108	17.923	30.022	29.233		
5.5	17.357	10.311	21.916	14.812	27.293	24.16		
6	14.79	8.664	19.655	12.447	25.018	20.301		
6.5			18.544	10.605	23.094	17.298	39.31	24.667
7			17.22	9.144	21.444	14.915	36.502	21.269
7.5			16.072	7.966	20.015	12.992	34.068	18.528
8			15.067	7.001	18.764	11.419	31.939	16.284
8.5			14.181	6.202	17.66	10.115	30.06	14.425
9			13.103	5.532	16.679	9.023	27.306	12.866
9.5			11.739	4.965	15.801	8.098	24.521	11.548

Deflection values -

Vertical deflection capacities are shown for a deflection limit of L/180. Where the deflection capacity shown exceeds the Ultimate (and SLS) it is only shown to allow the deflection at a lower load to be prorated. Where the dead load is a higher proportion of the total load than for normal roofing (tiled roof etc) then the allowable deflection limit should be reviewed.

Example

Span 6.0m, distance to first purlin 1.8m, distance to top side rail 1.8m,

Ultimate down $((\text{dead} + \text{services}) \times 1.4) + (\text{super} \times 1.6) \times 6.0 \times 1.8/2 = +6.847 \text{ kN}$

Ultimate uplift $((\text{dead} \times 1.0) - (\text{wind uplift} \times 1.4)) \times 6.0 \times 1.8/2 = -6.156 \text{ kN}$

Ultimate uplift $((\text{dead} + \text{super}) \times 1.2) - (\text{wind uplift} \times 1.2) \times 6.0 \times 1.8/2 = -1.166 \text{ kN}$

Pressure on side = wind pressure $\times 1.4 \times 6.0 \times 1.8/2 = +6.048 \text{ kN}$

Suction on side = wind suction $\times 1.4 \times 6.0 \times 1.8/2 = -9.072 \text{ kN}$

Consider if side load pressure or suction is critical.

Suction value is $9.072 \times 0.67\% = 6.078$ this value is just critical use this value.

The dead + services + super is not critical as it does not act in combination with any of the other loads. In this case the critical case is Ultimate uplift 6.156kN in combination with 9.072 x 0.67 suction (see use of chart above).

E185140 provides a horizontal pressure capacity of 5.6kN with a vertical uplift of 6.156

E215170 provides a horizontal pressure capacity of 7.2kN with a vertical uplift of 6.156

Thus the section that should be adopted is the E215170 with struts at mid span.



Eaves Beam - Load Charts

Use of the load charts

The vertical uplift capacity of the Eaves Beam is shown along the vertical axis and the horizontal capacity due to a positive pressure load along the horizontal axis. The diagonal lines marked with the span, show for each section how the vertical and horizontal loads interact.

The horizontal suction capacity for the Eaves Beam is higher than that shown for the pressure value so when comparing horizontal suction loads multiply the suction load by 0.67% and use this value in the table.

E185140 3.0m to 6.0m span

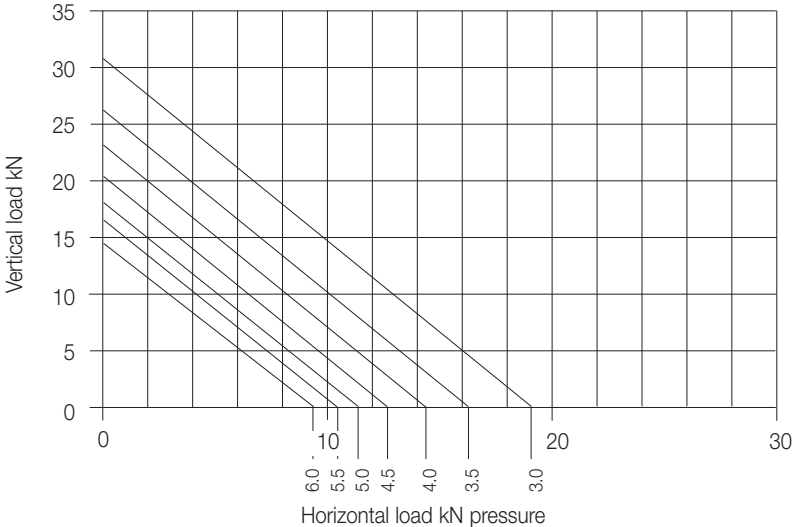

E215170 4.5m to 6.0m span

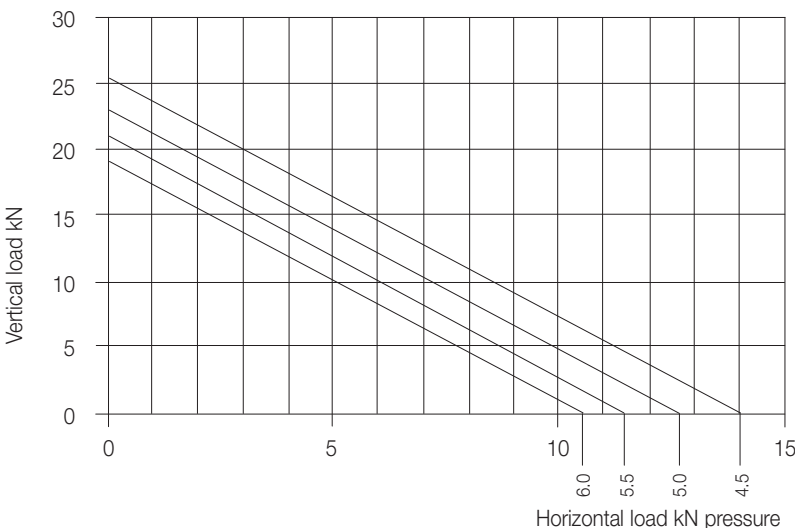

E265150 4.5m to 6.0m span

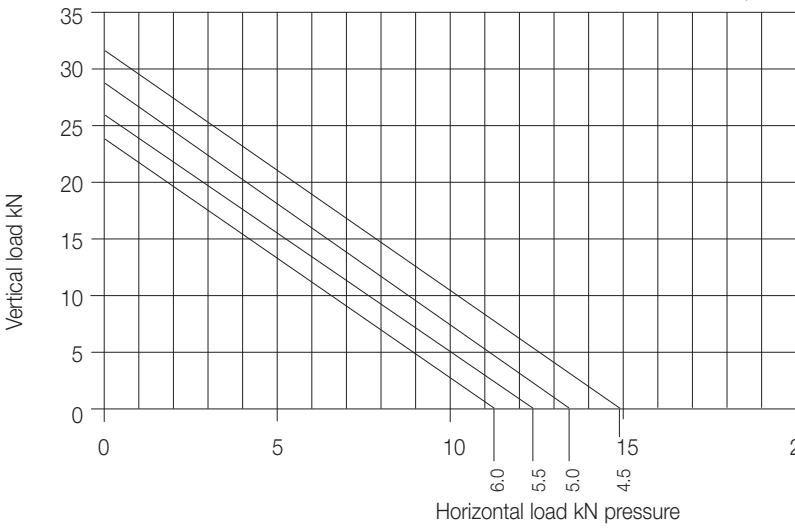

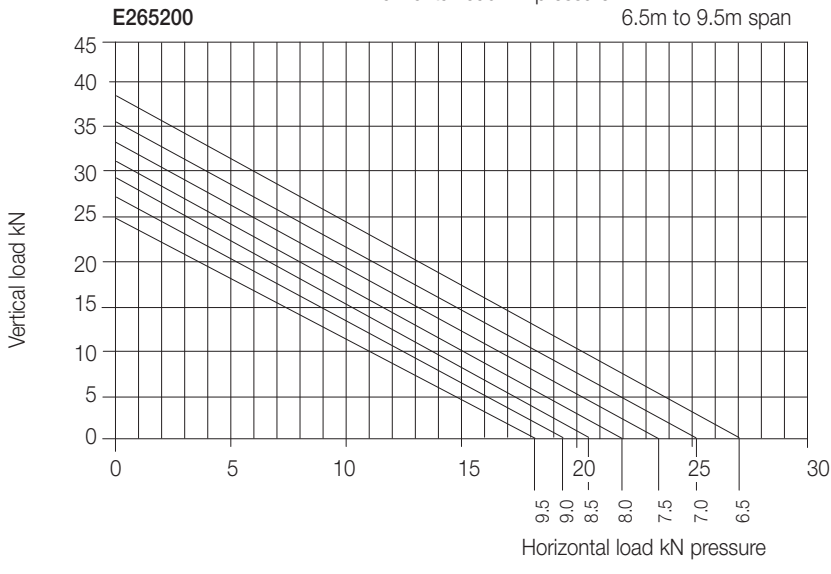
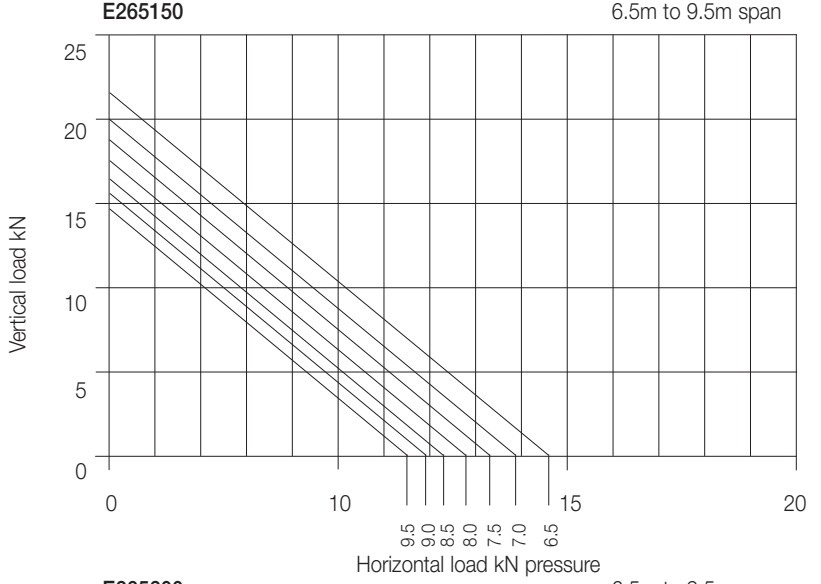
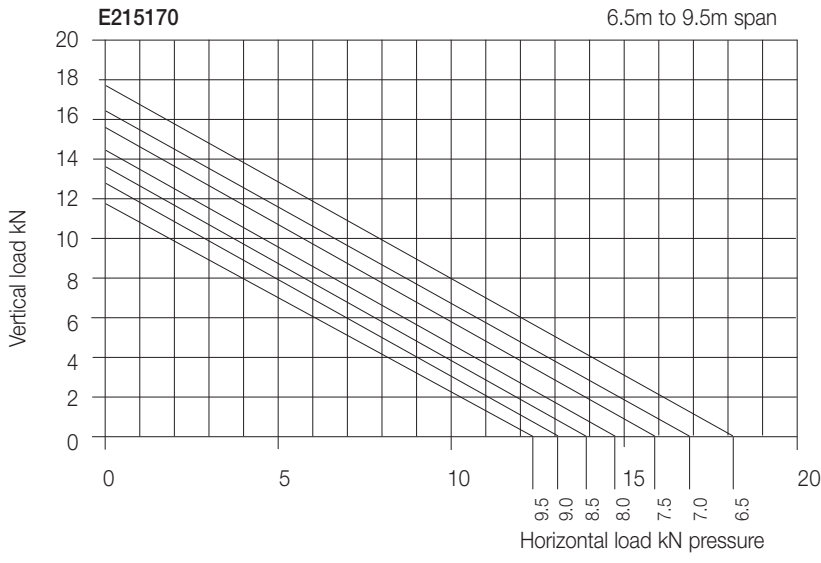



MULTIBEAM EVOLVED

Lighter | Stiffer | Stronger | Greener



Cladding Rails

Overview	64
Spanning Systems	65
Cladding Rail Restraints	66
Construction Details	72
Product Dimensions and References	78
Section Properties	86
Load Tables	87



Multibeam Cladding Rails - Overview



Applications

- All types of wall cladding
- Horizontal or vertically laid cladding
- Suitable for use with Multichannel
- Bay widths up to 15m

Material Specification

Hot dip galvanised steel to BS EN 10326:2004 and BS EN 10143:1993 'specifications for continuously hot dip zinc/metal coated structural steel strip'.

The minimum grade of steel used is **S450GD**, with Z275 zinc coating, giving an average coating thickness of 0.02mm to each side. Other galvanised coatings may be available. Please contact our Technical Department for advice.

Sustainability

The Multibeam system has been engineered to ensure maximum performance whilst minimising the material content.

Individual sections are packed together using low carbon mild steel, blued and waxed banding which is wholly recyclable.

Identification of the bundles is by paper labels which are biodegradable and can be recycled.

Softwood bearers, used to support the bundles in transport are from managed woodland and are reusable.

Reuse

Steel does not lose its strength or stiffness over time so remains a viable product for reuse. Assembly joints between components can be easily dismantled at any time to facilitate reuse. Sections can be recut to length and reholed to suit a revised use.

Recycling

Steel is one of the world's most recycled materials with over 40% of 'new' steel made from recycled steel. Kingspan's suppliers encourage, promote and assist in the return of steel for recycling.



Certification

Kingspan Structural Products has developed a fully integrated management system which combines all the common elements of **ISO 9001 (Quality), ISO 14001 (Environment) and OHSAS 18001 (Occupational Health and Safety)** into one system.

This simple coherent business management system enables the organisation to successfully achieve its purpose and mission to ensure that quality; safety and the environment are considered in all aspects of the business process. Further information on these certifications can be found on our website www.kingspanstructural.co.uk.

Range

- Section heights from 145mm to 350mm
- Flange widths from 65mm to 90mm
- Gauges from 1.2mm to 2.7mm

For full product dimensions see page 78. Other sizes may be available on specific request. Please contact our Technical Department for advice.

Lengths

- All lengths are catered for; requirements in excess of 18m, please contact our Sales Department.

MULTIBEAM EVOLVED

“ Multibeam is now stronger
so it spans further ”

Spanning Systems

Use double span system where possible
 • fewer components!
 • quicker to erect!

Multibeam can be used in all the popular and economic rail cladding systems.

The enhanced stiffness of the Multibeam shape makes it ideal for all span dimensions from the very short to the very long with rail bar lengths of 18m or more, making it practical for both handling and structural performance.

Sleeves

Sleeves are used to provide continuity at the joints between members and are available in three gauges (see page 82). When joining two sections of different gauges use the heaviest gauge rail to select the sleeve for that joint.

Double Span

Double span lengths of Multibeam section span across three frame supports and provide design economy and speed of erection. This spanning system always results in the lowest component count. To ensure equal load distribution across the supporting steel work the joints are staggered, typically requiring only one sleeve per run of rails.

Most double span bar lengths can be provided, although bays over 9m generally use single span lengths and are sleeved at every other joint to maintain continuity. Multibeam can be supplied in various lengths, however, please check with our Sales department for lengths over 18m.

System Types

Double Span

- Most popular system
- Ideal for all bay centres up to and including 8.25m
- Fewer components
- Quicker erection and programme completion

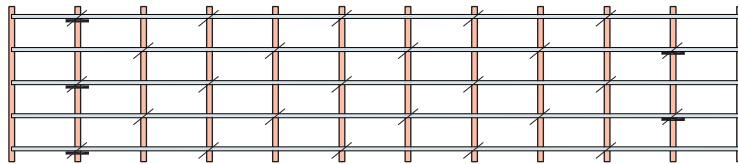

Single Span Sleeved Joints

- Option for all bay sizes particularly those with bay centres greater than 8.25m
- Where site restrictions (access, weight, craneage etc.) dictates use of single span length
- High component count
- Normal double span load tables can be used

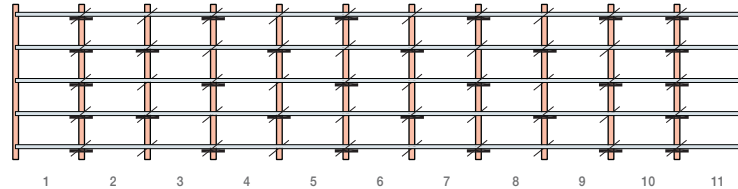

Single Span (between columns)

- Suitable for spanning between columns
- Reduces internal volume of building
- Useful for all applications where the front face of the rail must be flush with outer column flange
- Use design software for capacities (span is between outer connection bolts)

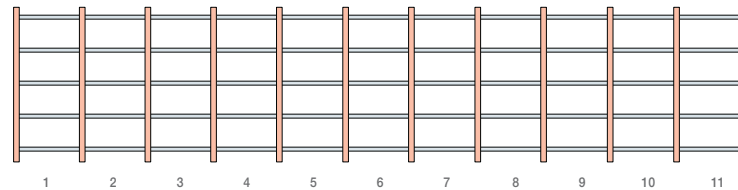

NB: Diagrams above are shown in plan view

— Sleeve / Joint

Cladding Rail Restraints

Multibeam Side rails can be used with all types of modern steel based side wall cladding whether laid vertically or horizontally.

- Insulated panels
- Twin skin
- Firewalls
- Rain screens

Insulated Panels

Two layers of steel bonded to an insulation core, laid vertically when through fixed directly to the side rails, will provide full restraint. The vertical restraint systems shown on page 67 can be used.

Where the insulated panel is only through fixed on one edge, trapping an under tongue on the adjacent panel the restraint shown on page 67 should be adopted but modified as follows; These systems have the bottom tube strut replaced with an angle strut and the diagonal wire replaced with a diagonal screwed rod.

Horizontally laid insulated panels should use the restraint systems shown on pages 68 and 69 and the rail capacities can be obtained from the Toolkit design software or from page 91 - 93. Generally the Insulated panels when laid horizontally should be fixed to the verticals between the rails and not by reducing the horizontal rail cross centres to match the panel cover width.

Twin Skin

Is made up of a inner liner profile and outer weather skin with an internal steel spacer system and thermal insulation. The liner tray is attached directly to the Multibeam side rail using self drill self tapping screws and this in connection with the restraint systems shown on page 67 will provide sufficient restraint to support the values shown in the load tables or design software.

Horizontally laid twin skin usually comprises of a vertically spanning liner tray and internal spacer system with the outer sheet laid horizontally and fixed back to the vertical internal spacer. With this arrangement the inner liner is through fixed to the Multibeam rail. When used with the restraint systems shown on pages 68 and 69, provides the necessary restraint to support the values shown in the load tables or Toolkit design software.

Firewall

Multibeam side rails can be used to support steel cladding based firewalls using either Insulated panels or twin skin cladding.

As long as the Multibeam side wall system is sufficiently designed to support the normal applied loads (dead weights and wind loadings) it will also support the requirements when the same cladded wall operates as a firewall see page 70.

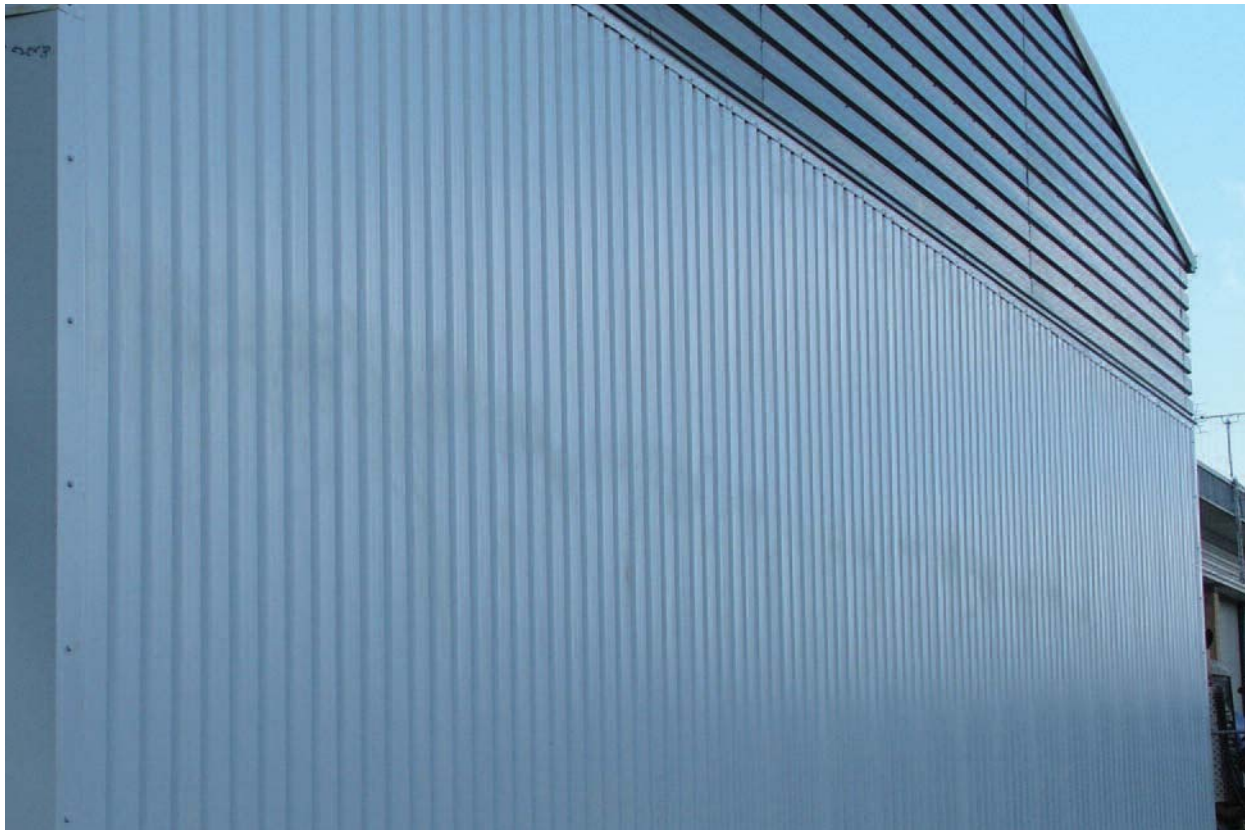

Restraints - Vertically Laid Cladding

Restraints for Bays up to 6.1m

The single strut system is utilised on buildings with bays up to 6.1m centres with adjustable diagonal tie wire as shown in the diagram.

Bays up to 3.0m generally do not require vertical support struts.

This system is for use with cladding which, when fixed restrains the Multibeam siderail outer flange.

* When wall exceeds 10m in height allow one set of diagonal ties for every 9.0m of height.

Maximum rail cross centres are 2m (for larger cross centres, contact Kingspan Technical).

Where the weight of the cladding is greater than 0.12 kN/m² please contact our Technical Department.

Where the insulated panel is only through fixed on one edge trapping an under tongue on the adjacent panel the restraint system shown on this page should be used. These systems have the bottom tube strut replaced with an angle strut and the diagonal tie wire replaced with a rod diagonal.

The strut system should be fitted between the bottom rails and the rails levelled before proceeding progressively upwards.

Where the cladding is clip fixed or fixed in such a way that the cladding can slip, relative to the side rail face please contact our Technical Department.

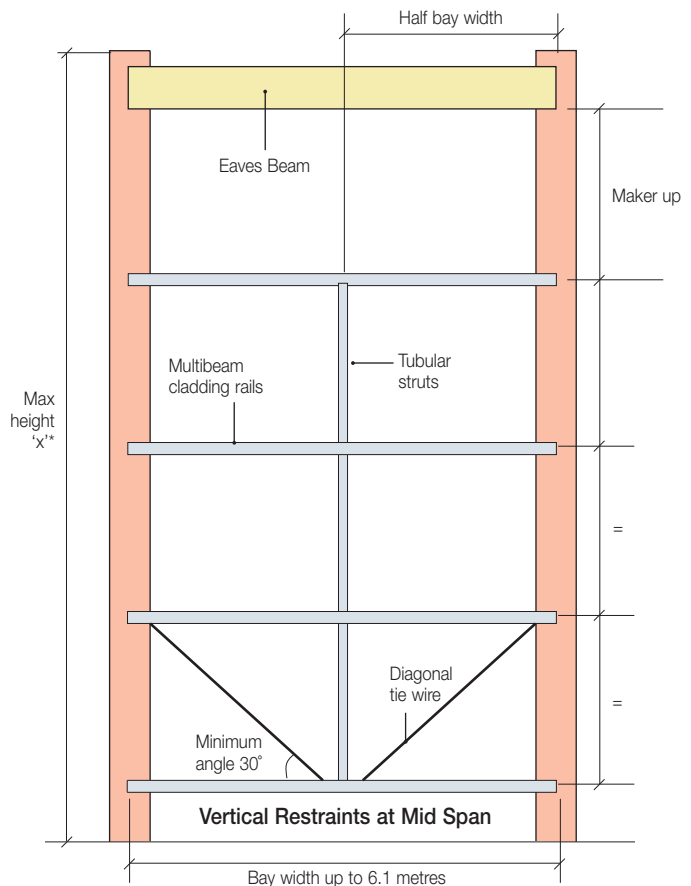

Restraints for Bays over 6.1m up to 9.0m

The double strut system is utilised on buildings with bays over 6.1m metres up to 9.0m.

* When wall exceeds 10m in height allow one set of diagonal ties for every 9.0m of height.

Where the insulated panel is only through fixed on one edge trapping an under tongue on the adjacent panel the restraint system shown on this page should be used. These systems have the bottom tube strut replaced with an angle strut and the diagonal tie wire replaced with a rod diagonal.

Where the cladding is clip fixed or fixed in such a way that the cladding can slip, relative to the side rail face please contact our Technical Department.

Maximum rail cross centres are 2m (for larger cross centres, contact Kingspan Technical).

Where the weight of the cladding is greater than 0.12 kN/m² please contact our Technical Department.

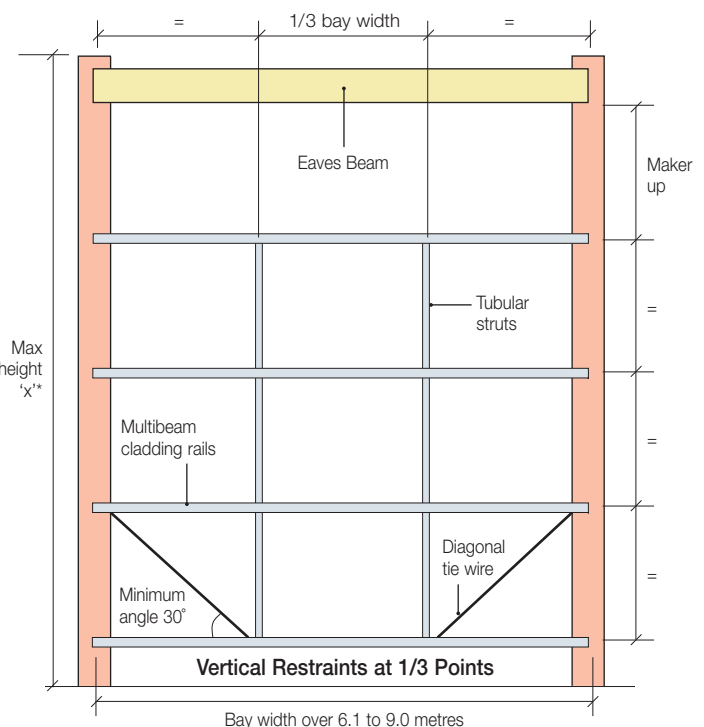

Bays over 9.0m

Bays over 9.0m are possible with Multibeam sections, for vertical restraints consult our Technical Department.

Restraints - Horizontally Laid Cladding

Cladding Joints at Stanchions

Horizontally laid panels require a structure to provide support for the panel self weight and also resist wind pressure and suction loads.

The efficient steelwork arrangement shown utilises Multibeam siderails with G140/150 vertical members at intermediate support locations.

This typical example also shows vertical restraint provided by standard diagonal tie wires and the connection to the Eaves Beam system.

Connection Details

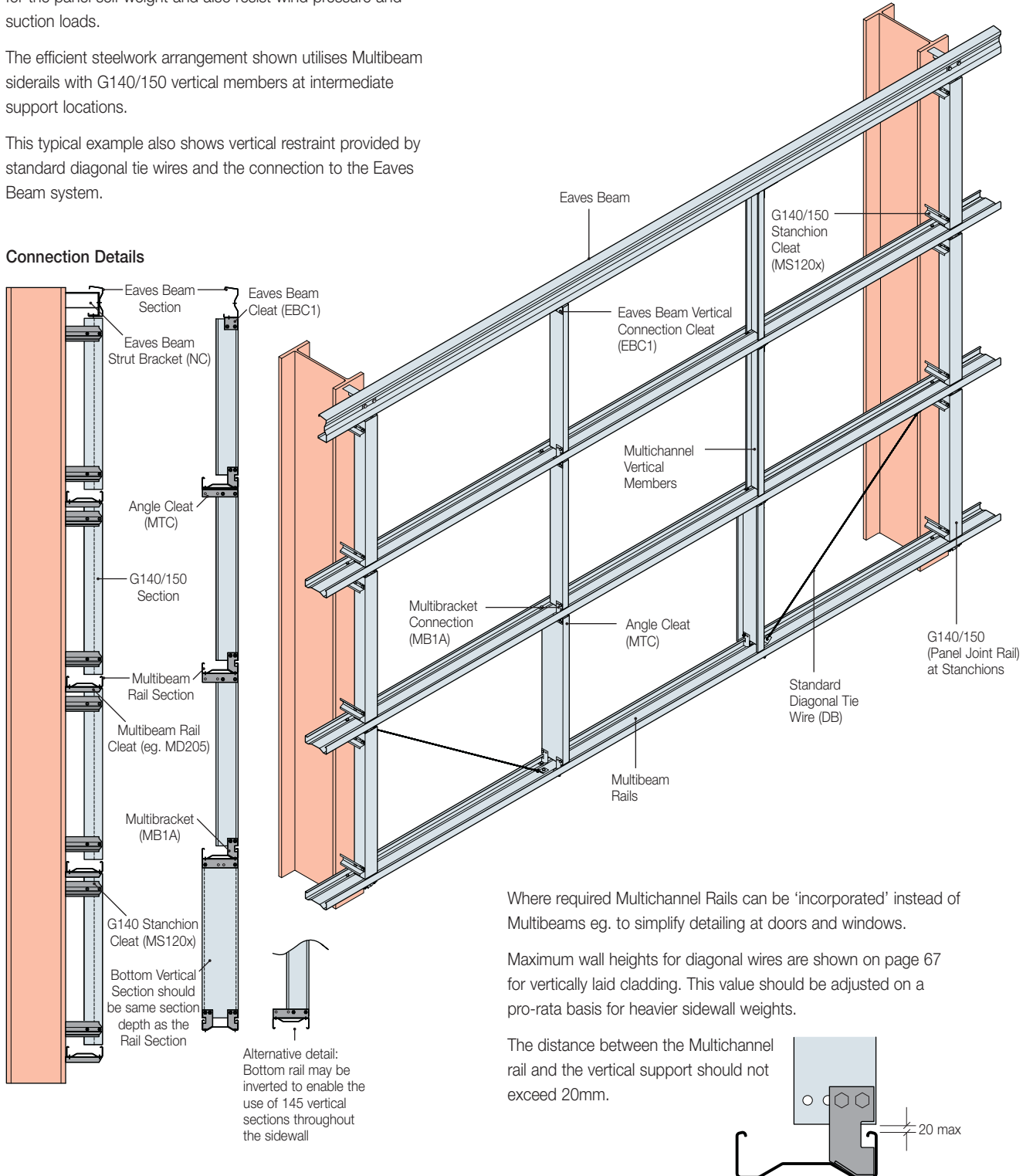

Cladding Joint Within Span

Where cladding is joined within the bay span, a wider flange is required in order to 'butt' the panels together. For this detail a G140/150 section is used together with rod diagonals.

Connection Details

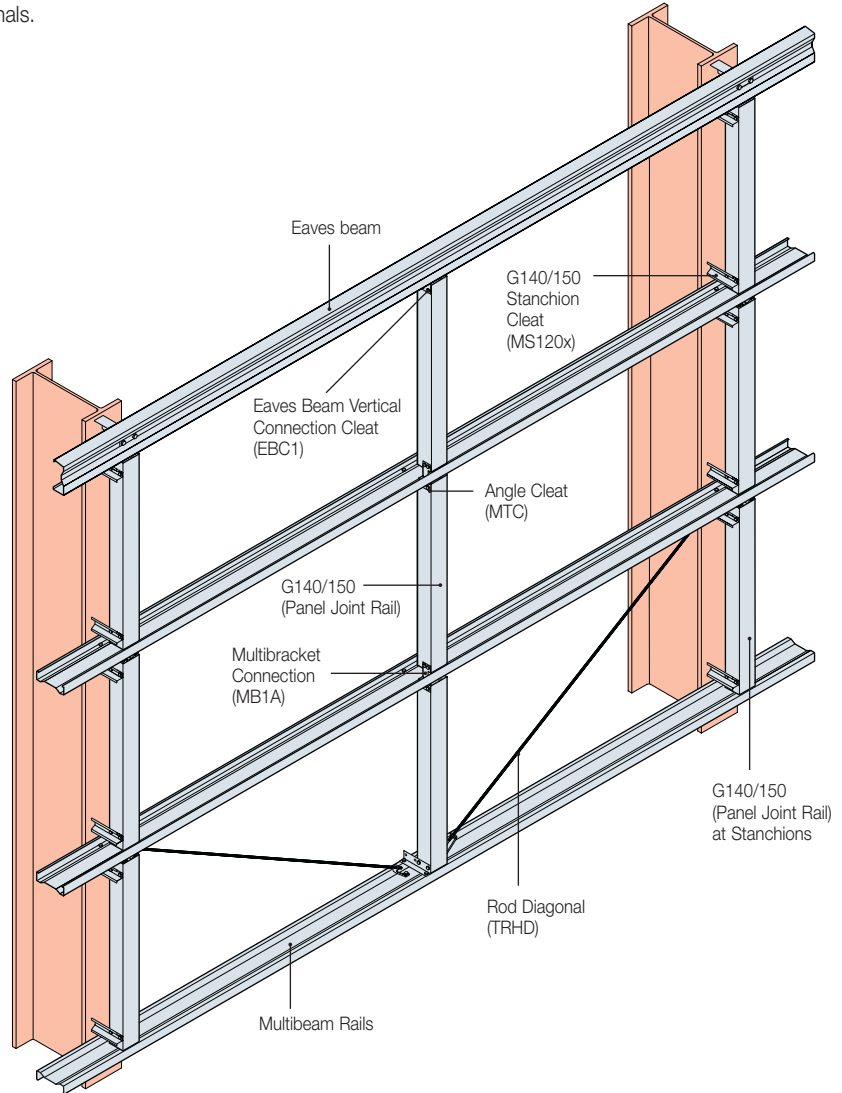
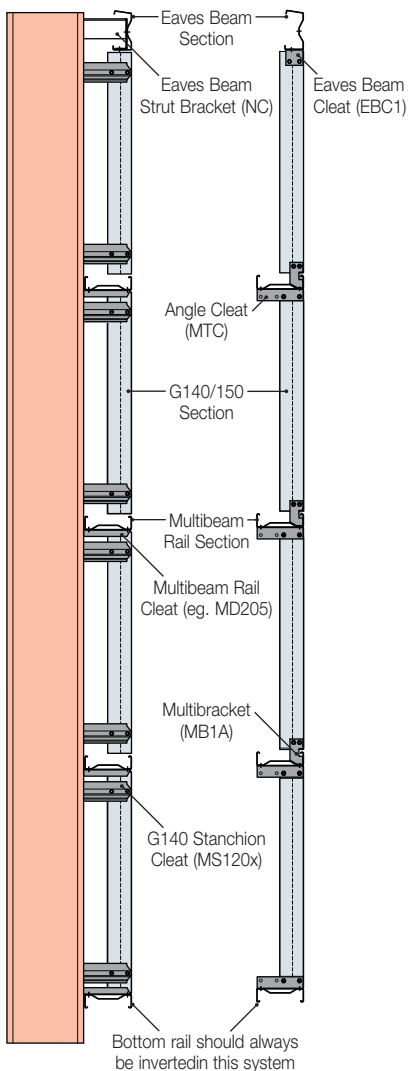

Horizontally laid cladding - Top Hat supports

Vertical top hat cladding supports provided by the sheeting contractor to support horizontally laid insulated panels - The restraints can be as shown on page 67 but the tube strut between the bottom pair of rails supporting the top hats must be replaced with a vertical Multichannel of the same depth of the rail and attached as shown on page 67. The standard tie wire must be replaced with a rod diagonal.

The top hats must be positioned at or very close to the rail restraint positions to avoid twisting of the horizontal member. The top hat section must be attached to all rails that it passes over using suitable fixings that can support the vertical dead loads and the wind pressure and suction loads.

Restraints - Firewall

This assembly of Multibeam side rails is designed to offer lateral support to the cladding assembly which provides the firewall performance of insulation integrity and stability for the periods derived from test or assessment. Periods up to 240mins are possible.

Firewall systems rely on the performance of the cladding. As the sheeting rails are relatively thin components they have very little heat sink capacity owing to their low mass. When subjected to a fire resistance test, the sheeting rails are heated very quickly and consequently lose their structural strength.

Sheeting rails whether exposed or concealed do retain sufficient strength to prevent the wall from significant lateral movement even after 240 minutes of exposure to a standard fire resistance test.

Sheeting rails with a minimum thickness of 1.2mm and above may be used for both twin skin cladding and composite panels, providing they are structurally capable of supporting the wall between the column spacings for the normal load case.

To reduce thermally induced stresses caused by expansion of the sheeting rails during the early stages of a fire, slotted holes are provided in the ends of the horizontal sheeting rails. The rails are shortened in length and low temperature fusible washers are used so that thermally induced movement can occur unrestricted.

The cladding suppliers requirements should always be checked especially where special or unusual details are required.

Typical Restraints for Firewall at Mid-Span

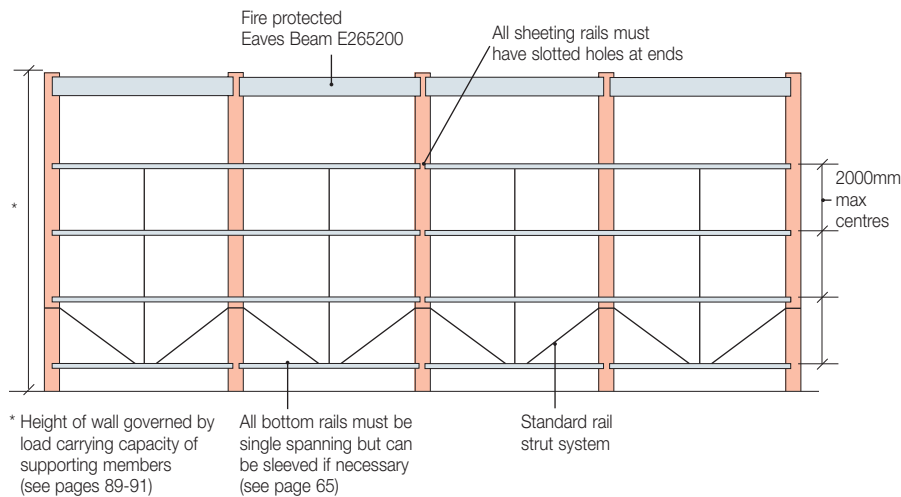

General Notes

1. Firewall rails should be 30mm shorter in length and should have 54mm x 14mm slotted holes to cater for expansion.
2. Although bottom rails must be single spanning to suit fire conditions, standard sleeves may be introduced to provide continuity for structural considerations.
3. At the discretion of the engineer, joints on rails may be staggered to provide uniform distribution of wind loadings to support structures.
4. Eaves Beam E265/200 is the only available section if supporting the weight of the wall and must be fire protected.

Firewall hole layout

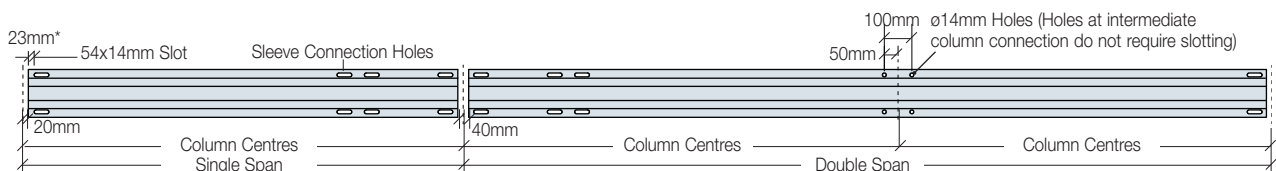

*Edge distance

Case Study

Arsenal Football Club Training Store, St. Albans

A new equipment store at Arsenal Football Club's world class training centre has been completed in style thanks to the specification of over 1,100 metres of Multibeam and nearly 600 metres of Multichannel from Kingspan Structural Products.



Cladding Rails



Construction Details - Multibeam Cladding Rails

Rail Connection

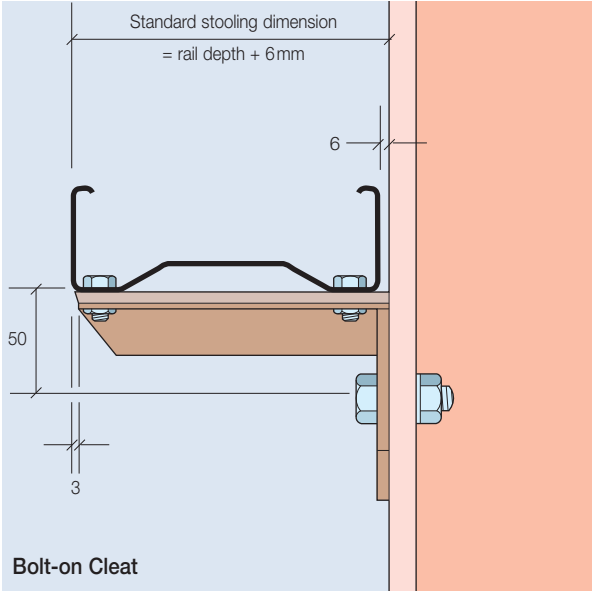
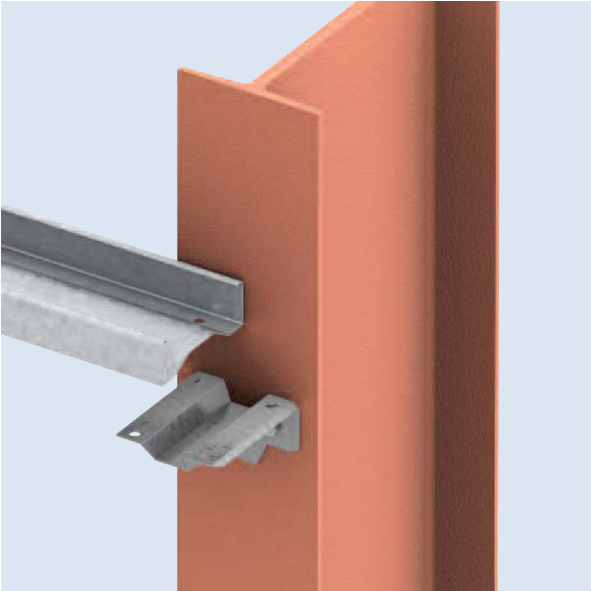

For product dimensions refer to page 78.

Cladding Rail Sleeve

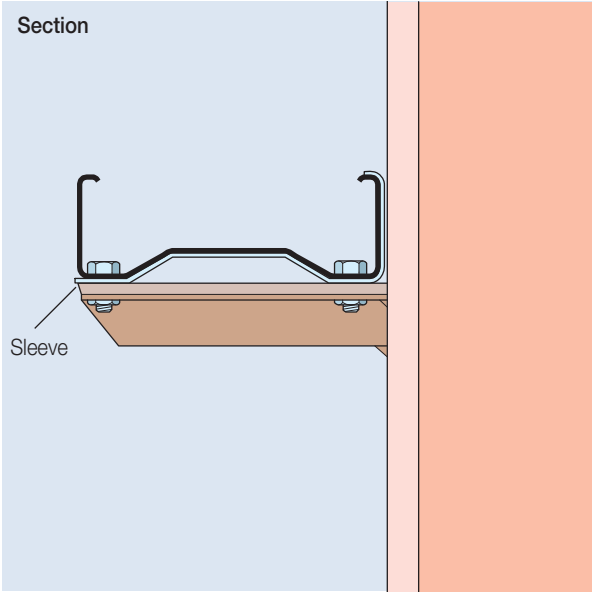
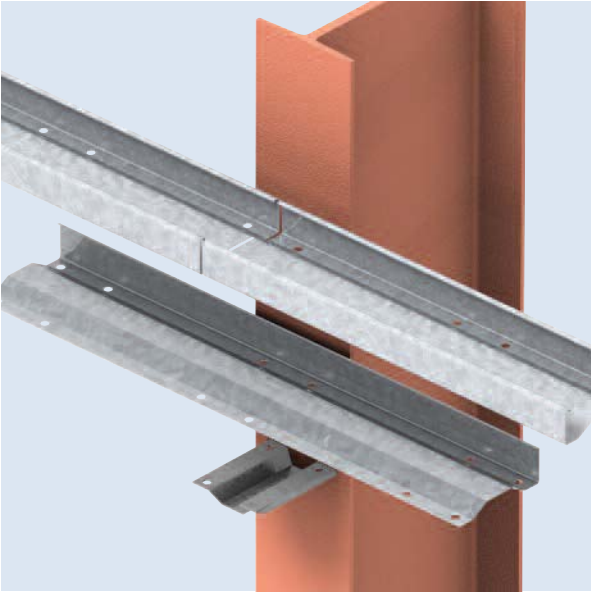

For product dimensions refer to page 82.

External Corner

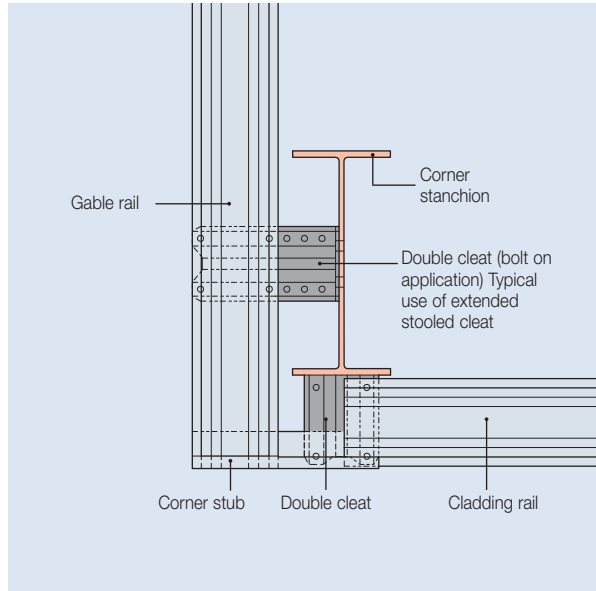
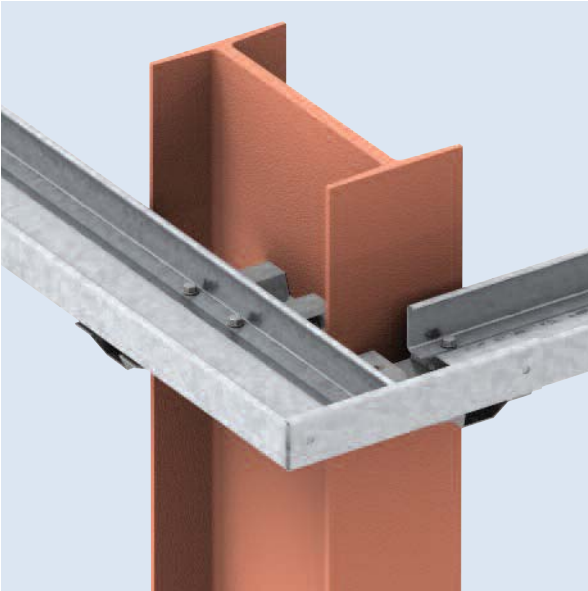

For product dimensions refer to page 78, 79 and 85.

Internal Corner

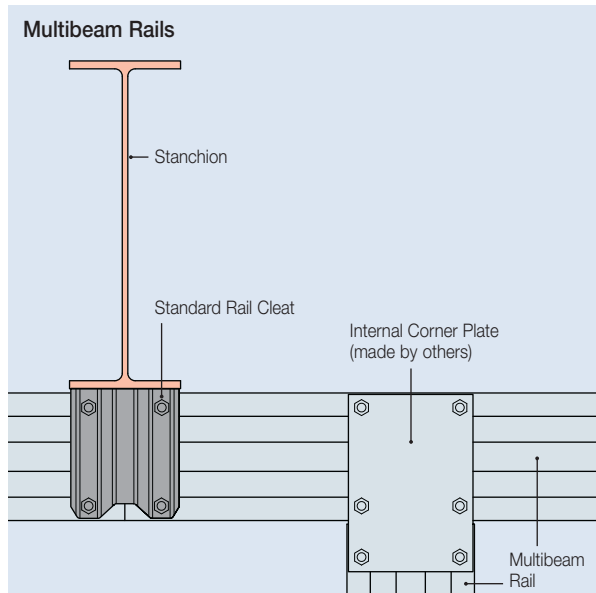
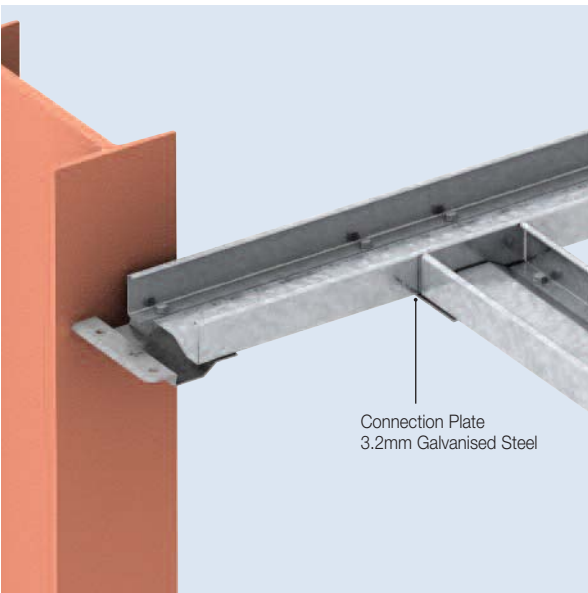

For product dimensions refer to page 78, 79.

Construction Details - Multibeam Cladding Rails

Slotted Cladding Rail on a Firewall

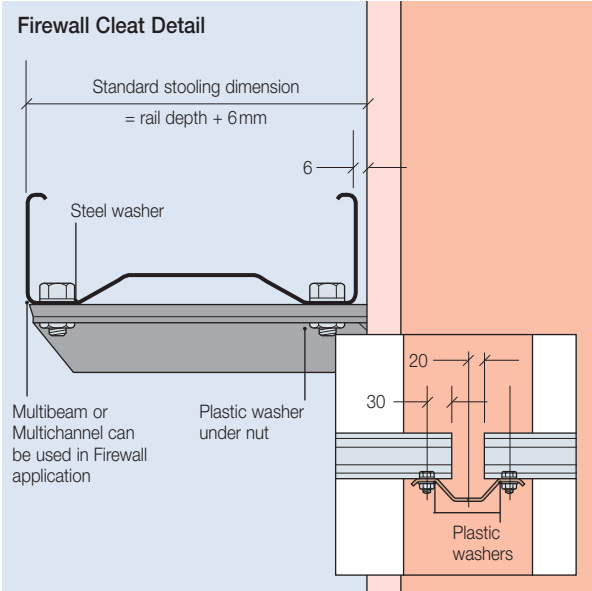
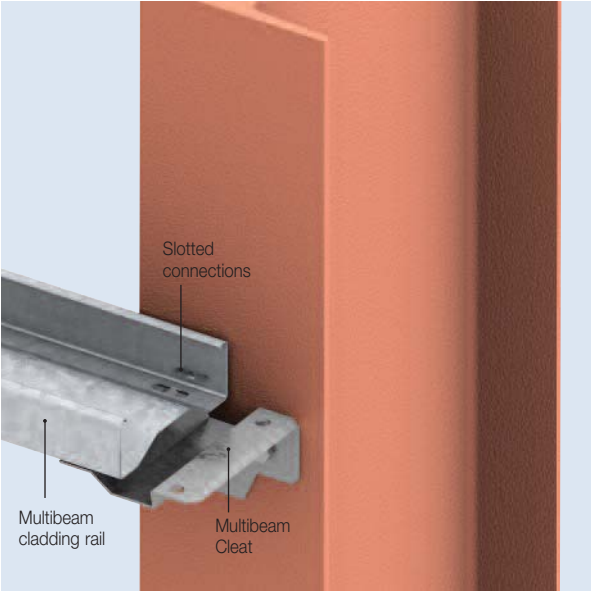

For product dimensions refer to page 78 and 79.

Rod Diagonal with G140/150

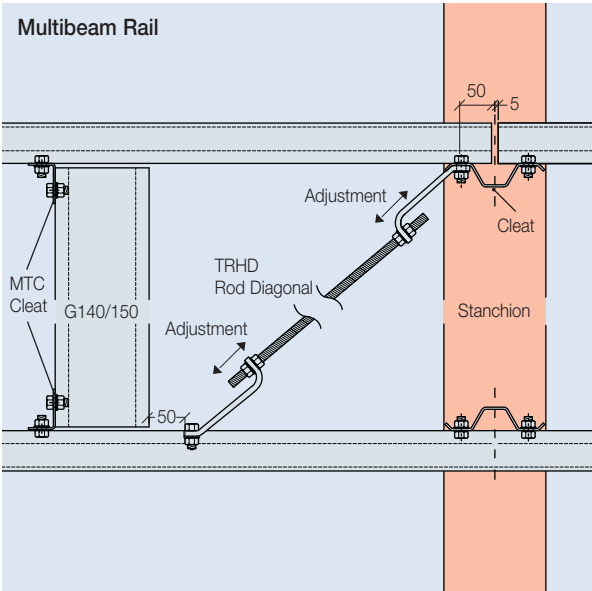

For product dimensions refer to page 85.

Stanchion Stay Type RNA



For product dimensions refer to page 84.

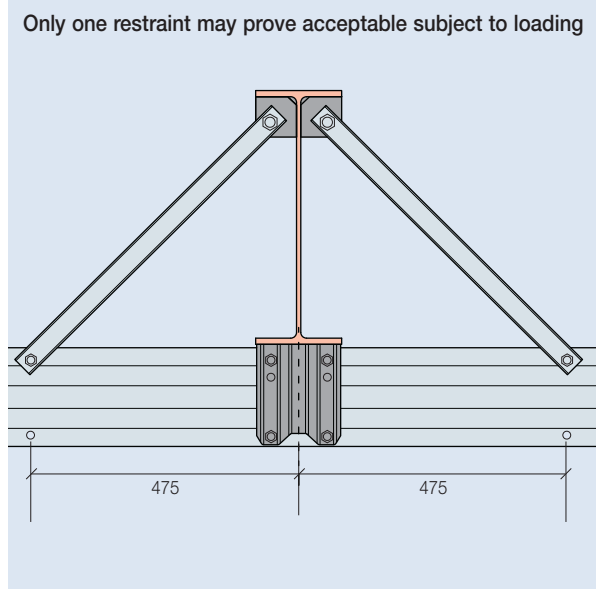

Stanchion Stay Type RNB



For product dimensions refer to page 84.

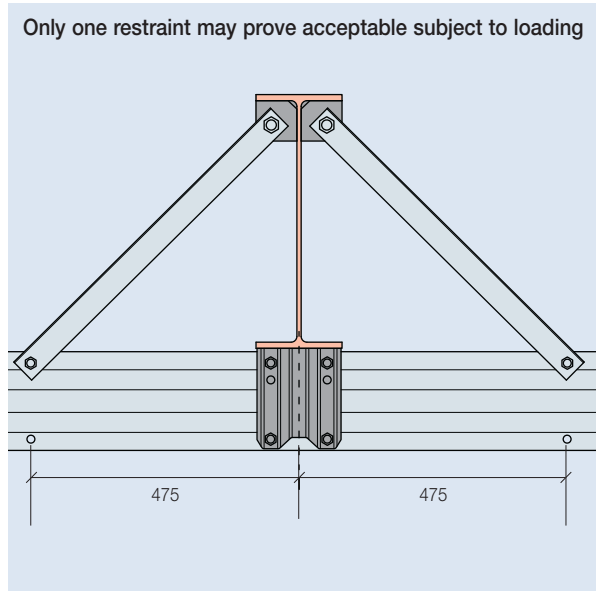

Construction Details - Multibeam Cladding Rails

Tube Strut Arrangements Type TSA

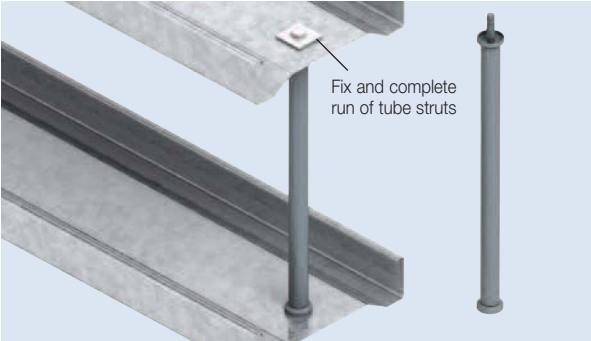

For product dimensions refer to page 83.

Tube Strut Arrangements Type TSB

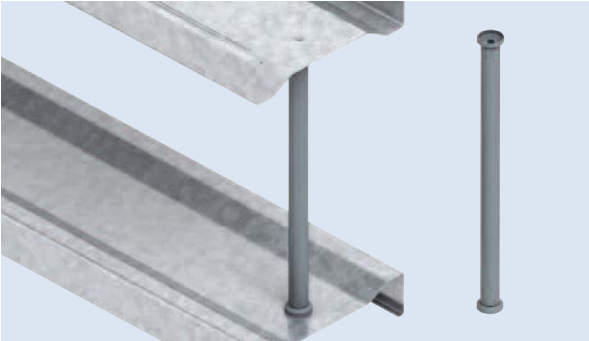

For product dimensions refer to page 83.

Tube Strut Arrangements Type TSB

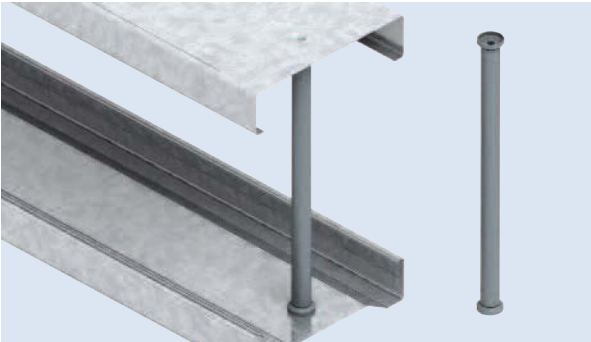

For product dimensions refer to page 83.

Bottom Strut Bracket

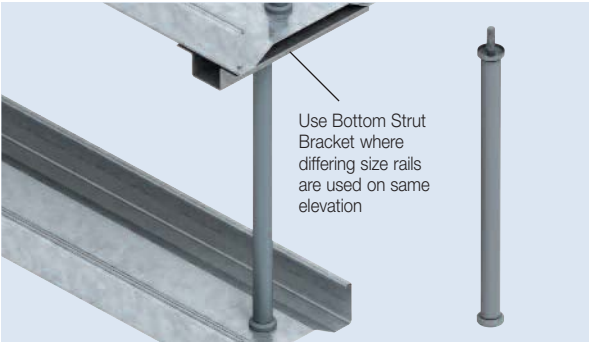

For product dimensions refer to page 83 and 85.

Diagonal Tie Wire Restraint

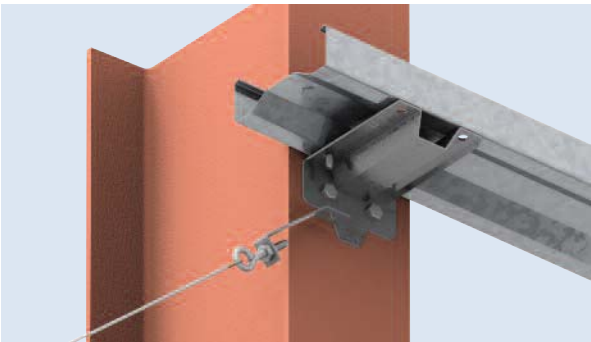

For product dimensions refer to page 84.

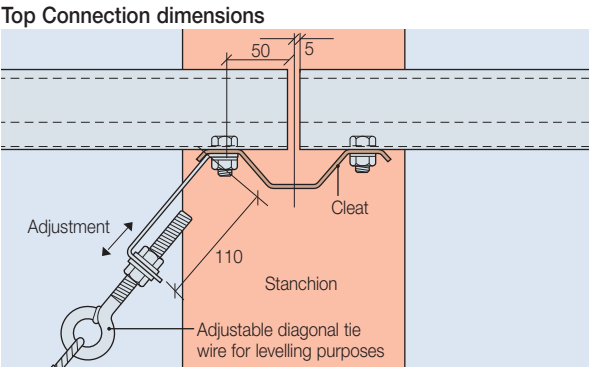

Door Openings

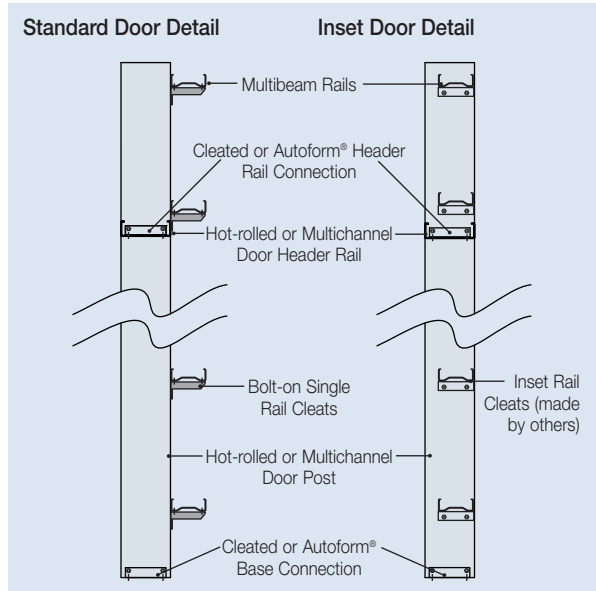
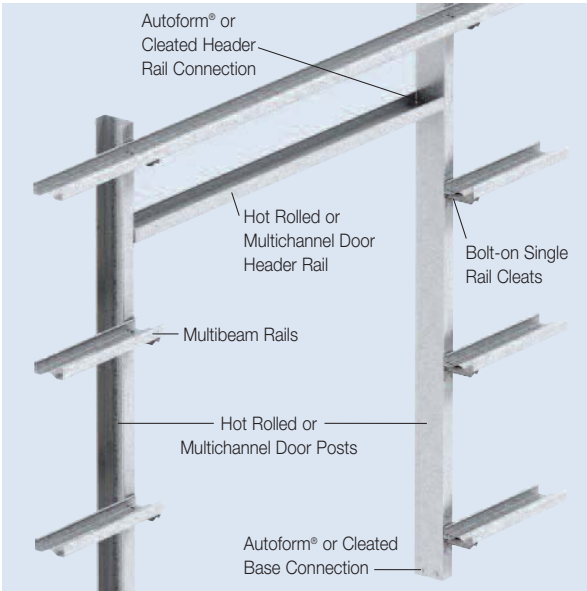

When the door framework needs to be set to the same level as the cladding rails, the rail cleats will need to be made by others - alternatively, Multichannel rails could be considered.

Window Openings

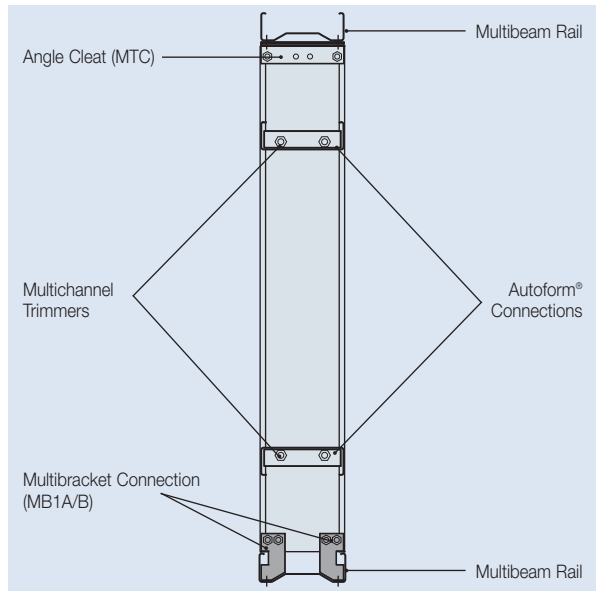
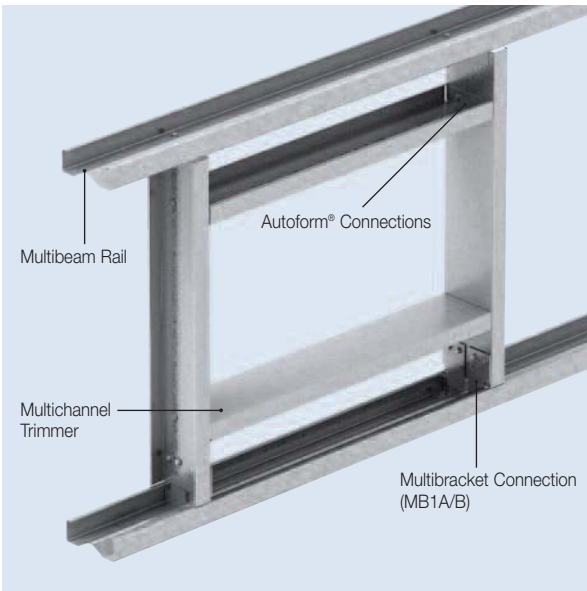

For Multichannel details see Multichannel section.

Product Dimensions and References

Multibeam Rails

Table 3:1 Multibeam Rails Product Dimensions and References

References	Weight Kg/m	A	Dims (mm)			Gauge (mm)
			B	C	D	
M145065120	2.75	145	65	8	20	1.20
M145065130	2.99	145	65	8	20	1.30
M145065140	3.21	145	65	8	20	1.40
M145065150	3.45	145	65	8	20	1.50
M145065160	3.69	145	65	8	20	1.60
M145065180	4.15	145	65	8	20	1.80
M145065200	4.63	145	65	8	20	2.00
M145065220	5.06	145	65	8	20	2.20
M175065120	3.02	175	65	38	20	1.20
M175065130	3.29	175	65	38	20	1.30
M175065140	3.52	175	65	38	20	1.40
M175065150	3.79	175	65	38	20	1.50
M175065160	4.05	175	65	38	20	1.60
M175065180	4.55	175	65	38	20	1.80
M175065200	5.08	175	65	38	20	2.00
M175065220	5.56	175	65	38	20	2.20
M175065250	6.35	175	65	38	20	2.50
M205065120	3.29	205	65	68	20	1.20
M205065130	3.58	205	65	68	20	1.30
M205065140	3.84	205	65	68	20	1.40
M205065150	4.13	205	65	68	20	1.50
M205065160	4.41	205	65	68	20	1.60
M205065170	4.67	205	65	68	20	1.70
M205065180	4.96	205	65	68	20	1.80
M205065200	5.53	205	65	68	20	2.00
M205065220	6.05	205	65	68	20	2.20
M205065250	6.91	205	65	68	20	2.50
M205065270	7.49	205	65	68	20	2.70
M235065130	3.86	235	65	98	20	1.30
M235065140	4.14	235	65	98	20	1.40
M235065150	4.45	235	65	98	20	1.50
M235065160	4.76	235	65	98	20	1.60
M235065170	5.04	235	65	98	20	1.70
M235065180	5.35	235	65	98	20	1.80
M235065200	5.97	235	65	98	20	2.00
M235065220	6.53	235	65	98	20	2.20
M235065250	7.46	235	65	98	20	2.50
M235065270	8.08	235	65	98	20	2.70
M265065140	4.46	265	65	128	20	1.40
M265065150	4.79	265	65	128	20	1.50
M265065160	5.13	265	65	128	20	1.60
M265065180	5.76	265	65	128	20	1.80
M265065200	6.43	265	65	128	20	2.00
M265065220	7.03	265	65	128	20	2.20
M265065250	8.03	265	65	128	20	2.50
M265065270	8.70	265	65	128	20	2.70
M300090150	5.86	300	90	94	40	1.50
M300090160	6.27	300	90	94	40	1.60
M300090180	7.05	300	90	94	40	1.80
M300090200	7.86	300	90	94	40	2.00
M300090250	9.82	300	90	94	40	2.50
M300090270	10.64	300	90	94	40	2.70
M350090150	6.43	350	90	144	40	1.50
M350090160	6.87	350	90	144	40	1.60
M350090180	7.72	350	90	144	40	1.80
M350090200	8.62	350	90	144	40	2.00
M350090250	10.77	350	90	144	40	2.50
M350090270	11.66	350	90	144	40	2.70

Reference Key

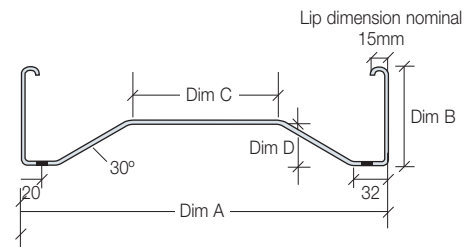
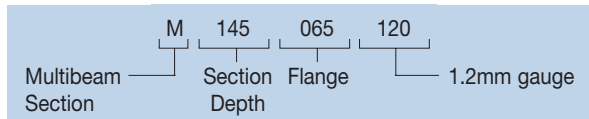

All dimensions in millimetres.

M145 Gauges	M175 Gauges	M205 Gauges	M235 Gauges	M265 Gauges	M300 Gauges	M350 Gauges
1.2	1.2	1.2	-	-	-	-
1.3	1.3	1.3	1.3	-	-	-
1.4	1.4	1.4	1.4	1.4	-	-
1.5	1.5	1.5	1.5	1.5	1.5	1.5
1.6	1.6	1.6	1.6	1.6	1.6	1.6
-	-	1.7	1.7	-	-	-
1.8	1.8	1.8	1.8	1.8	1.8	1.8
2.0	2.0	2.0	2.0	2.0	2.0	2.0
2.2	2.2	2.2	2.2	2.2	-	-
-	2.5	2.5	2.5	2.5	2.5	2.5
-	-	2.7	2.7	2.7	2.7	2.7

Multicleats

Table 3:2 Multicleat References

Sheeting Line (mm)	Multibeam Section Depths (mm)	Cleat Type			
		Weld-On		Bolt-On	
		Double	Single	Double	Single
-	G140/150	-	MS 120x	-	MS 120Bx
151	145	MD 145	MS 145	MD 145BB	MS 145BB
181	up to 175	MD 175	MS 175	MD 175BB	MS 175BB
211	up to 205	MD 205	MS 205	MD 205BB	MS 205BB
241	up to 235	MD 235	MS 235	MD 235BB	MS 235BB
271	up to 265	MD 265	MS 265	MD 265BB	MS 265BB
306	300	MD 300	MS 300	MD 300BB	MS 300BB
356	350	MD 350	MS 350	MD 350BB	MS 350BB

*All Cleats are supplied in unpainted black steel as standard. Painted or galvanised finishes are available at extra cost if required. Please note, for galvanised finish there is an extended lead time, please contact our Sales Department for more information.

Table 3:3 Multicleat Options

Options	Suffix	Example
Bolt-on Black	BB	MD175BB
Bolt-on Painted	BE	MD175BE
Bolt-on Galvanised	BG	MD175BG
Stiffened	S	MD265BS
Extended	X	MD265X300 (ie; 300mm from rafter face)

300/350 deep are supplied stiffened, see page 81 for details.

All multicleat holes shown are 14mm diameter.



Standard Single Cleat

Standard Double Cleat

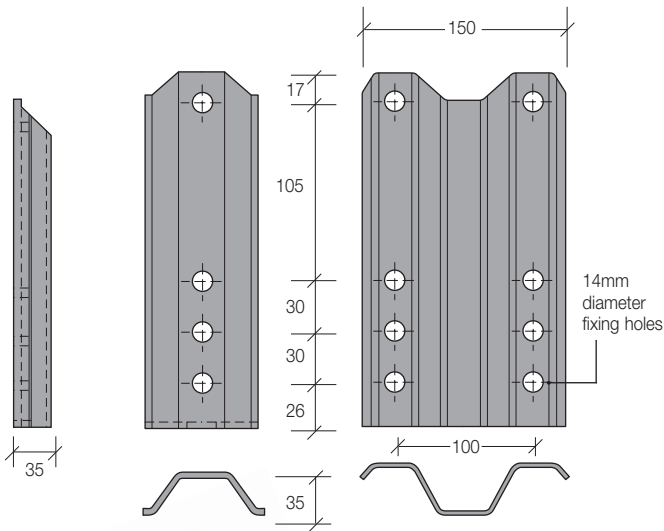

Single

Double

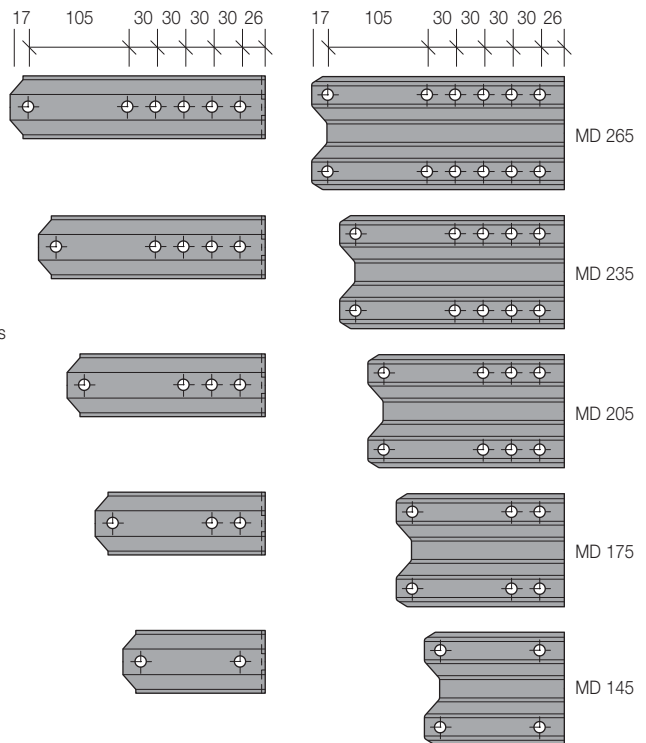

Multicleats provide the most economical solution for stooled off rails.

Cladding Rails

Product Dimensions and References

Bolt-on Rail Cleats

NB: Other finishes are available, please see table 3:3 on page 79.

Table 3:4 Base plate thicknesses

Multicleat Depth	Cleat Base Plate Thickness (mm)
G140/150	6
145	6
175	6
205	8
235	8
265	8
300	8
350	8

Table 3:5 Base plate holes cross centres

Base Plate Holes Cross Centres*	Dim H (mm)
50	55
60	55
70 (standard)	50
80	50
90	50
100	50

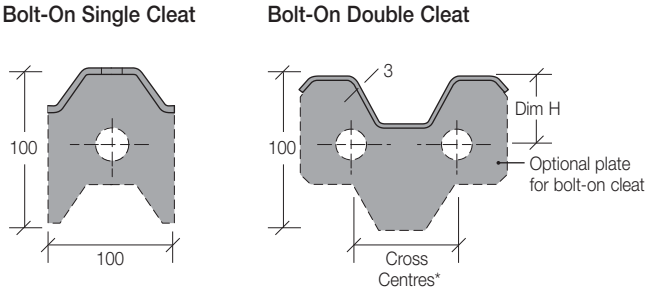
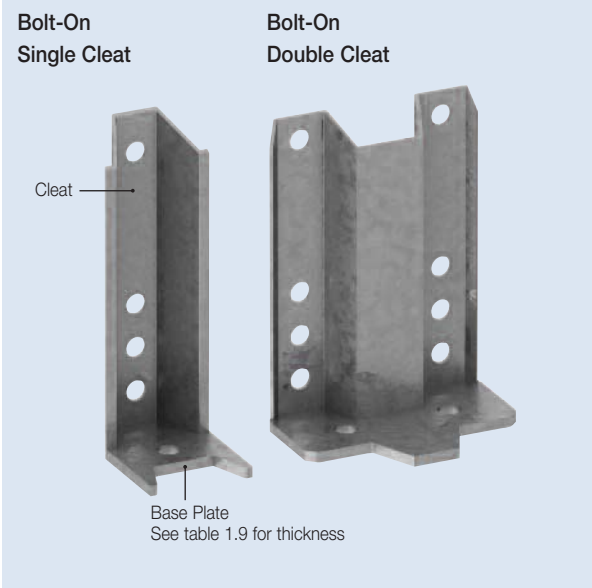

All base plate holes are 18mm

Multicleats allow differing section sizes to be used on any elevation, while maintaining a constant sheeting line.





Stiffened Rail Multicleats

All Multicleats are available with stiffeners where required. Add 'stiffened' to Multicleat reference when ordering. 300/350 deep are supplied stiffened.

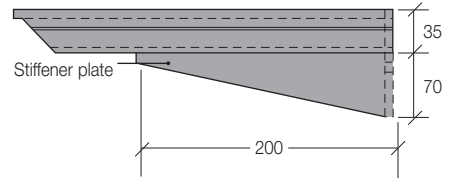

Multicleat Arrangement

Multicleats allow differing section sizes to be used on any elevation, while maintaining a constant sheeting line.

Diagram A

shows a 265 deep section fixed to a MD265 cleat.

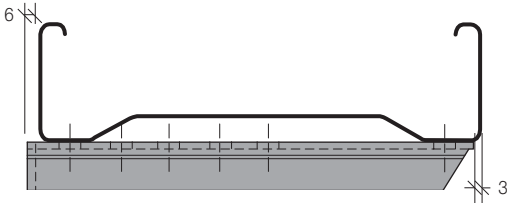
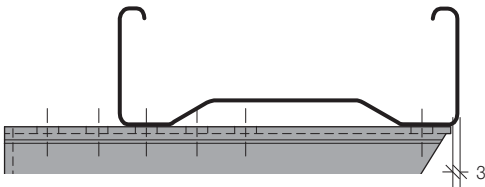

Diagram B

shows a 205 deep section fixed to a MD265 cleat.



Extended Rail Cleats

Extended cleats can be manufactured to meet your specific requirements. These are manufactured to order and will be at an additional cost.

NB: Add 'extended' to cleat reference when ordering.

Extended **double** cleats over 270mm long are supplied complete with stiffeners. **These are not available with single cleats.**

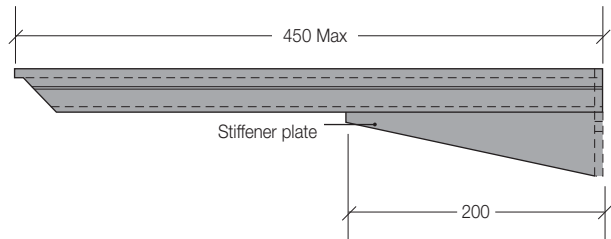

Product Dimensions and References

Cladding Rail Sleeves

Used to provide continuity at a rail joint normally at a single span to a double, or a single to a single span, or at all joints in heavy end bay layout.

Please specify sleeve reference as below.

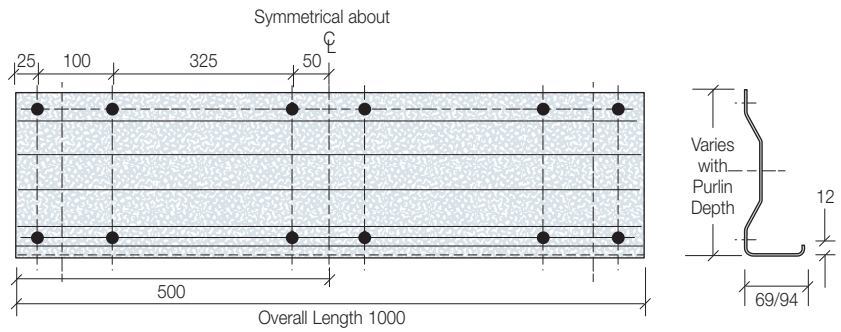

For design details see page 65. For construction details see page 72.

All holes are 14mm Dia unless noted.

Table 3:6
Multibeam Sleeve Product References

Multibeam Part Reference	Sleeve Part Reference	Nominal Sleeve Gauge (mm)	Multibeam Part Reference	Sleeve Part Reference	Nominal Sleeve Gauge (mm)		
M145065120	S145065A	1.6	M235065130	S235065A	1.6		
M145065130			M235065140				
M145065140			M235065150				
M145065150			M235065160				
M145065160	S145065B	2.0	M235065170	S235065B	2.0		
M145065180			M235065180				
M145065200			M235065200				
M145065220	S145065C	3.0	M235065220	S235065C	3.0		
M145065220			M235065250				
M175065120	S175065A	1.6	M235065270			S265065A	1.6
M175065130			M265065140				
M175065140			M265065150				
M175065150			M265065160				
M175065160	S175065B	2.0	M265065180	S265065B	2.0		
M175065180			M265065200				
M175065200			M265065220				
M175065220	S175065C	3.0	M265065250	S265065C	3.0		
M175065220			M265065270				
M175065250	S205065A	1.6	M300090150			S300090A	1.6
M205065120			M300090160				
M205065130			M300090180				
M205065140			M300090200				
M205065150	S205065B	2.0	M300090250	S300090C	3.0		
M205065160			M300090270				
M205065170			M350090150				
M205065180	S205065C	3.0	M350090160	S350090A	1.6		
M205065200			M350090180				
M205065220			M350090200				
M205065220			M350090250				
M205065250	S350090B	2.0	M350090270	S350090C	3.0		
M205065270			M350090270				

Sleeve Reference Key

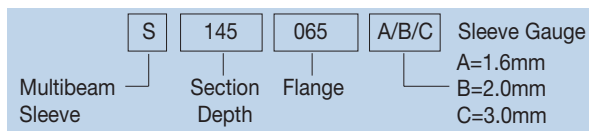

MULTIBEAM EVOLVED

“ Wider range of sleeves for a more economic solution ”

Tube Strut TSA

Used to restrain purlins and side rails

Part Reference

TSA0000

where 0000 = Rail Centres

eg; TSA1000 (Rail Centres = 1000mm)

Minimum Length = 150mm

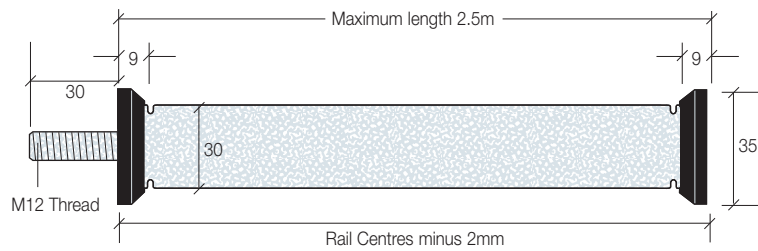

For design details see page 67. For construction details see page 76.

Tube Strut TSB

This tube strut is used to restrain side rails where a flush face is required

Part Reference

TSB0000

where 0000 = Rail Centres

eg; TSB1000 (Rail Centres = 1000mm)

Minimum Length = 150mm

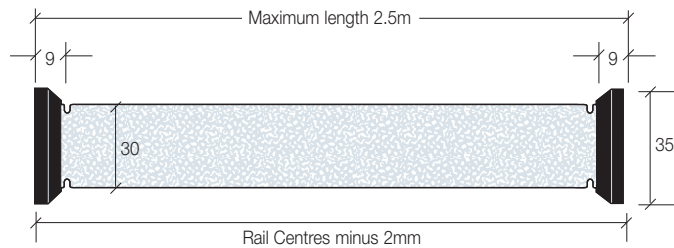

For design details see page 67. For construction details see page 76.

Tubular Ties

Used to restrain M145 side rails

Part Reference

TS14000

where 0000 = Rail Centres

eg; TS141000 (Rail Centres = 1000mm)

Minimum Length = 150mm

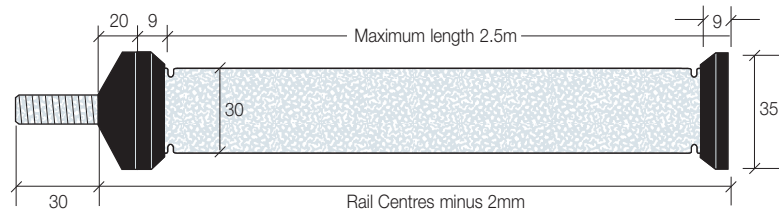

For design details see page 67. For construction details see page 76.

Clamp Plates

Used to fix and complete a run of tube struts, CA145 used with M145 rails

Part Reference

CA145

CA

For construction details see page 76.

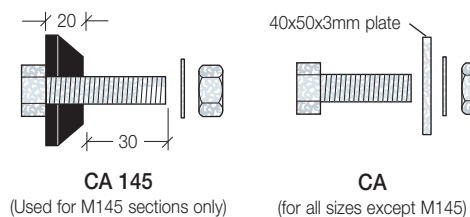

Product Dimensions and References

Rafter and Stanchion Restraint RNA

Channel stay to provide compression and tension restraint from the purlin or rail to the inner flange of the main frame

Part Reference

RNA0000

where 0000 = Length between Hole Centres

eg; RNA1000 (Hole Centres = 1000mm)

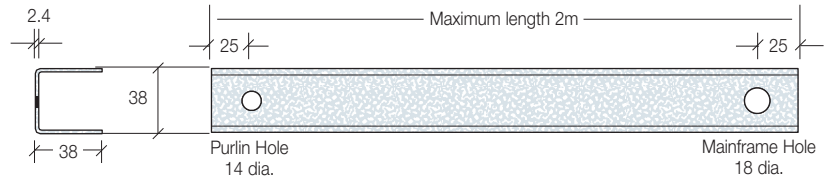

For construction details see page 75.

Rafter and Stanchion Restraint RNB

Angle stay to provide compression and tension restraint from the purlin or rail to the inner flange of the main frame suitable for smaller main frame sections

Part Reference

RNB0000

where 0000 = Length between Hole Centres

eg; RNB1000 (Hole Centres = 1000mm)

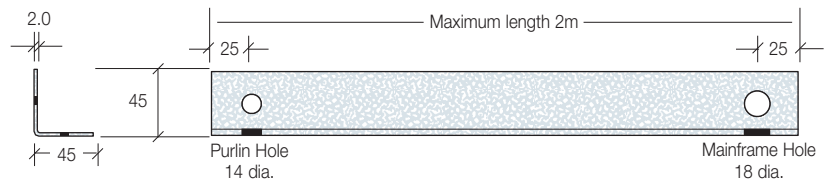

For construction details see page 75.

Diagonal Tie Wire

Used on some long purlin slopes to support the self weight of the cladding and transfer it to the rafters

Part Reference

DB

DA

Please state your dimension 'X' and 'Y'

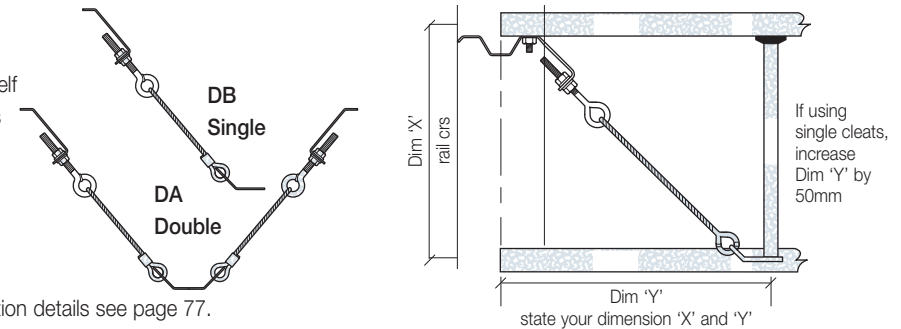

For design details see pages 67-69. For construction details see page 77.

Horizontal Panel Vertical Support

Used as the vertical support between Multibeam horizontal rails to support horizontally laid Insulated panels

Part Reference

G140/150

Maximum length = 8 metres

1.5mm galvanised steel.

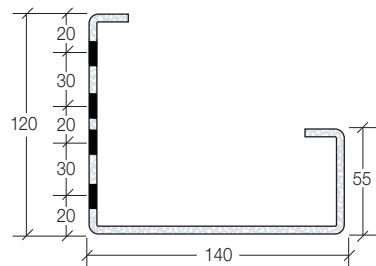

All holes 14mm diameter
Standard hole grouping are at backmarks of 20mm, 50mm, 70mm and 100mm.

Hole placement along the length to be specified by the customer.

For use within the span it can be provided complete with end connections attached

For design details see pages 68-69. For construction details see page 74.

Rail Stubs

Part Reference

SM0000

where 0000 = required length 'Dim L'

Manufactured from 2.7mm galvanised steel strip.

All holes 14 diameter.

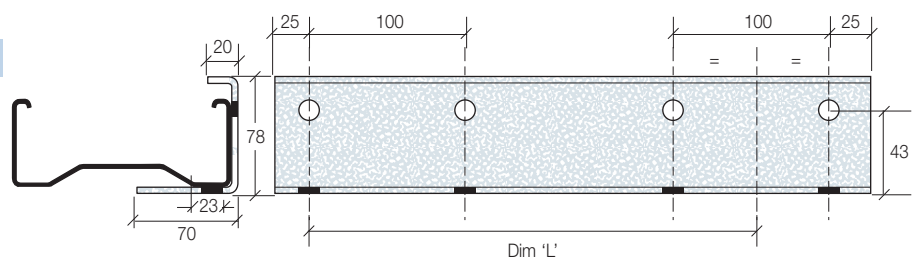

For construction details see page 73.

Rod Diagonal

The diagonal used with the rails when supporting horizontal cladding system when panel joint at mid-span to transfer loads to the main frame

Part Reference

TRHD0000
 where 0000 = length between hole centres
 eg; TRHD1000 (Hole Centres = 1000mm)

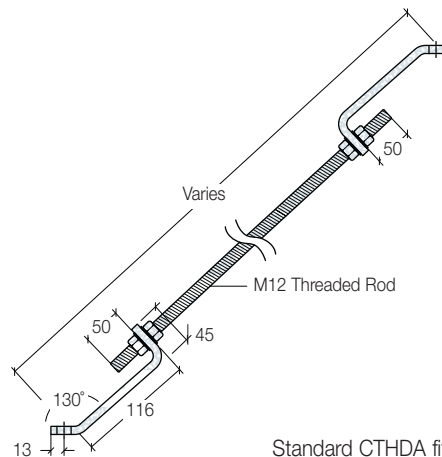

For design details see page 69. For construction details see page 74.

Standard CTHDA fittings to suit 50° angle. For non-standard angles contact our Technical Department.

Bottom Strut Bracket

Used where different depth side rails are used on the same wall to allow the tube struts to be aligned

Part Ref. Rail Size Part Ref. Rail Size

CSC145	145mm	CSC265	265mm
CSC175	175mm	CSC300	300mm
CSC205	205mm	CSC350	350mm
CSC235	235mm		

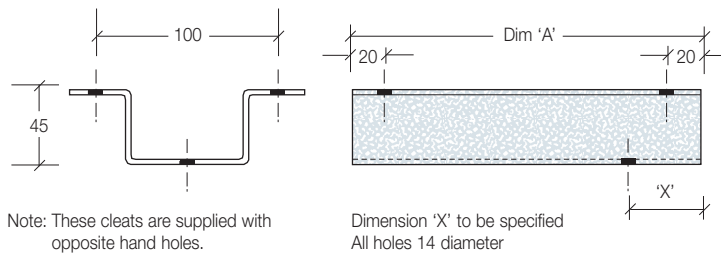

For construction details see page 76.

Multibracket

Multibrackets are used to make connections between Multichannels and Multibeam

Part Reference

MB1A (Left hand) as shown
 MB1B (Right hand)

Material 3.0mm galvanised steel.
 All holes 14 diameter.

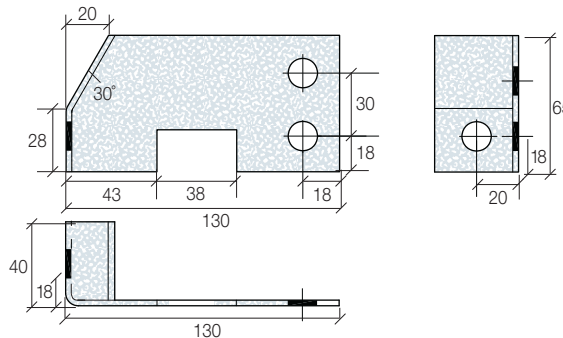

For design details see pages 68-69. For construction details see page 74.

Note: Multibrackets are not suitable for connecting sections to a 90mm flange.

MTC Cleats

Angle cleat to attach Multibeam or Multichannel together

Part Reference Rail Depth

MTC145	145mm
MTC175	175mm
MTC205	205mm
MTC235	235mm
MTC265	265mm
MTC300	300mm
MTC350	350mm

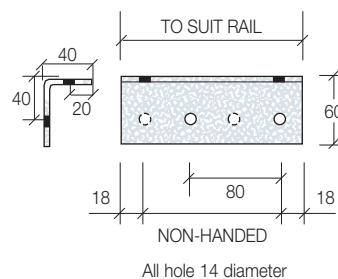

Note: These cleats are supplied with opposite hand holes.

For construction details see page 74.

Multibeam Cladding Rails - Section Properties

Table 3:7 Multibeam section properties

Sectionmm	Thickness cm ²	Area kg/m	Weight cm ⁴	Ixx cm ³	Gross Zxx cm ⁴	Iyy cm ³	Zyy cm	Rxx cm	Ryy
M145065120	1.20	3.68	2.75	121.15	16.72	19.24	4.56	5.74	2.29
M145065130	1.30	3.99	2.99	131.11	18.09	20.74	4.91	5.73	2.28
M145065140	1.40	4.30	3.21	140.99	19.45	22.21	5.26	5.73	2.27
M145065150	1.50	4.60	3.45	150.77	20.80	23.66	5.60	5.72	2.27
M145065160	1.60	4.91	3.69	160.48	22.14	25.08	5.94	5.72	2.26
M145065180	1.80	5.51	4.15	179.69	24.79	27.86	6.60	5.71	2.25
M145065200	2.00	6.11	4.63	198.62	27.40	30.54	7.23	5.70	2.24
M145065220	2.20	6.71	5.06	217.21	29.97	33.12	7.84	5.69	2.22
M175065120	1.20	4.03	3.02	187.92	21.48	19.28	4.53	6.83	2.19
M175065130	1.30	4.37	3.29	203.42	23.25	20.79	4.89	6.82	2.18
M175065140	1.40	4.71	3.52	218.82	25.01	22.26	5.23	6.82	2.17
M175065150	1.50	5.04	3.79	234.07	26.76	23.71	5.57	6.81	2.17
M175065160	1.60	5.38	4.05	249.21	28.49	25.13	5.91	6.81	2.16
M175065180	1.80	6.04	4.55	279.21	31.92	27.91	6.56	6.80	2.15
M175065200	2.00	6.70	5.08	308.79	35.30	30.60	7.19	6.79	2.14
M175065220	2.20	7.36	5.56	337.89	38.62	33.18	7.80	6.78	2.12
M175065250	2.50	8.33	6.35	380.74	43.52	36.89	8.68	6.76	2.10
M205065120	1.20	4.38	3.29	272.82	26.62	19.32	4.51	7.89	2.10
M205065130	1.30	4.75	3.58	295.39	28.83	20.83	4.86	7.89	2.09
M205065140	1.40	5.11	3.84	317.82	31.01	22.30	5.21	7.88	2.09
M205065150	1.50	5.48	4.13	340.05	33.18	23.75	5.55	7.88	2.08
M205065160	1.60	5.84	4.41	362.13	35.34	25.18	5.88	7.87	2.08
M205065170	1.70	6.21	4.67	384.50	37.52	26.63	6.22	7.87	2.07
M205065180	1.80	6.57	4.96	405.91	39.61	27.96	6.54	7.86	2.06
M205065200	2.00	7.29	5.53	449.12	43.82	30.64	7.17	7.85	2.05
M205065220	2.20	8.00	6.05	491.68	47.98	33.23	7.77	7.84	2.04
M205065250	2.50	9.06	6.91	554.41	54.10	36.94	8.64	7.82	2.02
M205065270	2.70	9.76	7.49	595.41	58.10	39.29	9.20	7.81	2.01
M235065130	1.30	5.12	3.86	408.72	34.79	20.86	4.85	8.93	2.02
M235065140	1.40	5.52	4.14	439.84	37.44	22.34	5.19	8.92	2.01
M235065150	1.50	5.92	4.45	470.70	40.07	23.79	5.53	8.92	2.01
M235065160	1.60	6.31	4.76	501.35	42.68	25.21	5.86	8.91	2.00
M235065170	1.70	6.70	5.04	531.67	45.26	26.59	6.18	8.91	1.99
M235065180	1.80	7.10	5.35	562.18	47.85	28.00	6.51	8.90	1.99
M235065200	2.00	7.88	5.97	622.25	52.97	30.69	7.14	8.89	1.97
M235065220	2.20	8.65	6.53	681.48	58.01	33.27	7.75	8.88	1.96
M235065250	2.50	9.80	7.46	768.88	65.45	36.98	8.62	8.86	1.94
M235065270	2.70	10.56	8.08	826.07	70.32	39.33	9.17	8.84	1.93
M265065140	1.40	5.93	4.46	586.70	44.29	22.37	5.17	9.95	1.94
M265065150	1.50	6.36	4.79	627.97	47.40	23.82	5.51	9.94	1.94
M265065160	1.60	6.78	5.13	668.97	50.50	25.25	5.84	9.93	1.93
M265065180	1.80	7.63	5.76	750.38	56.64	28.04	6.49	9.92	1.92
M265065200	2.00	8.47	6.43	830.83	62.71	30.72	7.12	9.91	1.91
M265065220	2.20	9.30	7.03	910.21	68.71	33.31	7.72	9.89	1.89
M265065250	2.50	10.54	8.03	1027.46	77.56	37.01	8.59	9.87	1.87
M265065270	2.70	11.36	8.70	1104.27	83.36	39.36	9.14	9.86	1.86
M300090150	1.50	7.75	5.86	1017.30	67.83	54.24	9.60	11.45	2.64
M300090160	1.60	8.27	6.27	1084.30	72.30	57.60	10.20	11.45	2.64
M300090180	1.80	9.31	7.05	1217.51	81.18	64.22	11.37	11.44	2.63
M300090200	2.00	10.34	7.86	1349.43	89.97	70.67	12.52	11.42	2.61
M300090250	2.50	12.89	9.82	1673.13	111.56	86.07	15.27	11.39	2.58
M300090270	2.70	13.91	10.64	1800.32	120.04	91.94	16.32	11.38	2.57
M350090150	1.50	8.48	6.43	1470.17	84.02	54.45	9.72	13.16	2.53
M350090160	1.60	9.05	6.87	1567.25	89.57	57.83	10.33	13.16	2.53
M350090180	1.80	10.19	7.72	1760.37	100.61	64.50	11.52	13.14	2.52
M350090200	2.00	11.32	8.62	1951.76	111.54	70.99	12.69	13.13	2.50
M350090250	2.50	14.12	10.77	2422.01	138.42	86.50	15.49	13.09	2.47
M350090270	2.70	15.24	11.66	2607.02	148.99	92.42	16.57	13.08	2.46

Horizontal panel vertical support member properties

Section	Thickness mm	Area cm ²	Weight kg/m	Ixx cm ⁴	Zxx Pos cm ³	Zxx Neg cm ³	Iyy cm ⁴	Zyy cm ³	Rxx cm	Ryy cm
G140/150	1.50	5.10	4.00	78.08	22.67	9.13	164.43	28.81	3.91	5.63

Multibeam Cladding Rails - Load Tables

Multibeam Cladding Rails

Ultimate Loads

Multibeam used as cladding rail supports, sections supported on Multibeam cleats as shown in the Multibeam Handbook LOADS SHOWN ARE UDL'S IN kN AND ARE ULTIMATE VALUES.

Values against deflection should be compared against values at working load. Loading assumes cladding provides restraint to the

Multibeam, and that the Multibeam restraint system as detailed in the Multibeam Handbook is used. Lining and levelling of the bottom base rails should be completed before fitting further rails or tube struts. Maximum height limit 10m. Use grade 8.8 bolts for M265, M300 and M350.

For Rafter and Stanchion Stays please refer to page 125.

Table 3:6 Double Span Siderails (Vertical Cladding)

Span (m)	Siderail Section	Weight kg/m	Ultimate Uniformly Distributed Load (kN)		Working Load to Produce Deflection of Span/150
			Pressure	Suction	
4.5	M145065120	2.75	11.95	9.33	-
	M145065130	2.99	14.04	11.23	-
	M145065140	3.21	16.21	12.96	-
	M145065150	3.45	18.40	14.72	-
	M145065160	3.69	20.61	16.49	20.04
	M145065180	4.15	24.96	19.97	22.44
	M145065200	4.63	29.10	23.28	24.80
	M145065220	5.06	33.02	26.42	27.12
	M175065120	3.02	14.66	11.73	-
	M175065130	3.29	17.29	13.83	-
	M175065140	3.52	19.98	15.99	-
	M175065150	3.79	22.45	17.96	-
	M175065160	4.05	24.52	19.61	-
	M175065180	4.55	29.74	23.34	-
	M175065200	5.08	34.07	27.25	-
	M175065220	5.56	38.74	31.00	-
	M175065250	6.35	45.42	36.34	-
	M205065120	3.29	16.44	13.02	-
	M205065130	3.58	19.44	14.98	-
	M205065140	3.84	22.53	17.40	-
	M205065150	4.13	25.67	19.89	-
	M205065160	4.41	28.82	22.40	-
	M205065170	4.67	31.97	24.55	-
	M205065180	4.96	33.90	26.47	-
	M205065200	5.53	39.16	30.69	-
	M205065220	6.05	44.66	35.08	-
	M205065250	6.91	52.52	41.37	-
	M205065270	7.49	57.57	45.42	-
	M235065130	3.86	22.89	17.58	-
	M235065140	4.14	26.61	20.35	-
M235065150	4.45	30.38	23.35	-	
M235065160	4.76	34.07	26.73	-	
M235065170	5.04	37.23	28.82	-	
M235065180	5.35	40.75	31.47	-	
M235065200	5.97	46.89	36.54	-	
M235065220	6.53	53.69	44.28	-	
M235065250	7.46	63.30	52.41	-	
M235065270	8.08	69.52	57.66	-	
5.0	M145065120	2.75	10.94	8.75	-
	M145065130	2.99	12.82	10.26	-
	M145065140	3.21	14.78	11.82	14.26
	M145065150	3.45	16.76	13.41	15.25
	M145065160	3.69	18.75	15.00	16.23
	M145065180	4.15	22.67	18.13	18.17
	M145065200	4.63	26.39	21.12	20.09
	M145065220	5.06	29.93	23.94	21.97
	M175065120	3.02	13.48	10.79	-
	M175065130	3.29	15.85	12.68	-
	M175065140	3.52	18.28	14.63	-
	M175065150	3.79	20.50	16.40	-

Span (m)	Siderail Section	Weight kg/m	Ultimate Uniformly Distributed Load (kN)		Working Load to Produce Deflection of Span/150	
			Pressure	Suction		
4.5	M175065160	4.05	22.36	17.89	-	
	M175065180	4.55	27.07	21.66	-	
	M175065200	5.08	30.96	24.76	-	
	M175065220	5.56	35.16	28.13	34.17	
	M175065250	6.35	41.17	32.94	38.51	
	M205065120	3.29	15.19	12.15	-	
	M205065130	3.58	17.90	14.32	-	
	M205065140	3.84	20.69	16.55	-	
	M205065150	4.13	23.51	18.81	-	
	M205065160	4.41	26.35	21.08	-	
	M205065170	4.67	29.19	23.02	-	
	M205065180	4.96	30.92	24.74	-	
	M205065200	5.53	35.65	28.52	-	
	M205065220	6.05	40.60	32.48	-	
	M205065250	6.91	47.67	38.13	-	
	M205065270	7.49	52.21	41.76	-	
	M235065130	3.86	21.17	16.94	-	
	M235065140	4.14	24.53	19.62	-	
	M235065150	4.45	27.93	22.34	-	
	M235065160	4.76	31.25	25.00	-	
	M235065170	5.04	34.09	27.27	-	
	M235065180	5.35	37.26	29.65	-	
	M235065200	5.97	42.78	34.20	-	
	M235065220	6.53	48.89	41.25	-	
	M235065250	7.46	57.54	48.54	-	
	M235065270	8.08	63.13	53.26	-	
	5.5	M145065120	2.75	10.08	8.06	-
		M145065130	2.99	11.79	9.44	10.96
		M145065140	3.21	13.58	10.86	11.78
		M145065150	3.45	15.38	12.30	12.60
M145065160		3.69	17.19	13.75	13.41	
M145065180		4.15	20.76	16.60	15.02	
M145065200		4.63	24.15	19.32	16.60	
M145065220		5.06	27.36	21.89	18.16	
M175065120		3.02	12.47	9.97	-	
M175065130		3.29	14.62	11.70	-	
M175065140		3.52	16.84	13.47	-	
M175065150		3.79	18.86	15.09	-	
M175065160		4.05	20.55	16.44	-	
M175065180		4.55	24.83	19.87	23.34	
M175065200		5.08	28.36	22.69	25.81	
M175065220	5.56	32.19	25.75	28.24		
M175065250	6.35	37.65	30.12	31.82		
M205065120	3.29	14.10	11.28	-		
M205065130	3.58	16.57	13.25	-		
M205065140	3.84	19.11	15.29	-		
M205065150	4.13	21.68	17.35	-		
M205065160	4.41	24.27	19.41	-		
M205065170	4.67	26.85	21.17	-		

- indicates the load to produce a deflection of span/150 exceeds ultimate UDL capacity

Multibeam Cladding Rails - Load Tables

Table 3:6 Double Span Siderails (Vertical Cladding) (Cont.)

Span (m)	Siderail Section	Weight kg/m	Ultimate Uniformly Distributed Load (kN)		Working Load to Produce Deflection of Span/150	Span (m)	Siderail Section	Weight kg/m	Ultimate Uniformly Distributed Load (kN)		Working Load to Produce Deflection of Span/150		
			Pressure	Suction					Pressure	Suction			
	M205065180	4.96	28.42	22.73	-		M235065270	8.08	53.30	44.97	-		
	M205065200	5.53	32.71	26.17	-		M265065140	4.46	23.92	19.12	-		
	M205065220	6.05	37.21	29.77	-		M265065150	4.79	28.17	22.29	-		
	M205065250	6.91	43.63	34.90	-		M265065160	5.13	30.45	23.74	-		
	M205065270	7.49	47.76	38.20	-		M265065180	5.76	37.04	28.00	-		
	M235065130	3.86	19.67	15.73	-		M265065200	6.43	42.88	33.11	-		
	M235065140	4.14	22.72	18.18	-		M265065220	7.03	48.56	39.15	-		
	M235065150	4.45	25.82	20.66	-		M265065250	8.03	58.89	46.22	-		
	M235065160	4.76	28.85	23.08	-		M265065270	8.70	64.59	50.80	-		
	M235065170	5.04	31.42	25.14	-		6.5	M175065120	3.02	10.82	8.66	-	
	M235065180	5.35	34.30	27.44	-			M175065130	3.29	12.65	10.12	12.17	
	M235065200	5.97	39.31	31.43	-			M175065140	3.52	14.53	11.63	13.10	
	M235065220	6.53	44.87	37.86	-			M175065150	3.79	16.25	13.00	14.01	
	M235065250	7.46	52.72	44.48	-			M175065160	4.05	17.67	14.13	14.91	
	M235065270	8.08	57.80	48.77	-			M175065180	4.55	21.30	17.04	16.71	
	M265065140	4.46	25.63	20.49	-			M175065200	5.08	24.28	19.43	18.48	
	M265065150	4.79	30.24	23.32	-			M175065220	5.56	27.52	22.02	20.22	
	M265065160	5.13	32.74	24.86	-			M175065250	6.35	32.14	25.71	22.78	
	M265065180	5.76	39.93	29.51	-			M205065120	3.29	12.30	9.84	-	
	M265065200	6.43	46.30	35.06	-			M205065130	3.58	14.40	11.52	-	
	M265065220	7.03	52.50	41.61	-			M205065140	3.84	16.56	13.25	-	
	M265065250	8.03	63.76	49.32	-			M205065150	4.13	18.74	14.99	-	
	M265065270	8.70	69.99	54.32	-			M205065160	4.41	20.94	16.75	-	
	6.0	M145065120	2.75	9.34	7.47			8.51	M205065170	4.67	23.13	18.23	23.01
		M145065130	2.99	10.92	8.73			9.21	M205065180	4.96	24.44	19.55	24.29
		M145065140	3.21	12.55	10.04			9.90	M205065200	5.53	28.07	22.46	26.88
		M145065150	3.45	14.21	11.37			10.59	M205065220	6.05	31.88	25.50	29.42
		M145065160	3.69	15.87	12.70			11.27	M205065250	6.91	37.30	29.84	33.18
		M145065180	4.15	19.14	15.31			12.62	M205065270	7.49	40.79	32.63	35.63
		M145065200	4.63	22.25	17.80			13.95	M235065130	3.86	17.18	13.74	-
M145065220		5.06	25.19	20.15	15.26	M235065140		4.14	19.78	15.82	-		
M175065120		3.02	11.59	9.27	-	M235065150		4.45	22.40	17.93	-		
M175065130		3.29	13.57	10.85	-	M235065160		4.76	24.89	19.98	-		
M175065140		3.52	15.60	12.48	15.37	M235065170		5.04	27.14	21.71	-		
M175065150		3.79	17.46	13.97	16.44	M235065180		5.35	29.58	23.67	-		
M175065160		4.05	19.00	15.20	17.50	M235065200		5.97	33.81	27.04	-		
M175065180		4.55	22.93	18.35	19.61	M235065220		6.53	38.52	32.50	-		
M175065200		5.08	26.16	20.93	21.69	M235065250		7.46	45.16	38.10	-		
M175065220		5.56	29.67	23.74	23.73	M235065270		8.08	49.45	41.72	49.43		
M175065250		6.35	34.67	27.74	26.74	M265065140	4.46	22.41	17.91	-			
M205065120		3.29	13.14	10.52	-	M265065150	4.79	26.34	20.85	-			
M205065130		3.58	15.41	12.33	-	M265065160	5.13	28.44	22.65	-			
M205065140		3.84	17.74	14.20	-	M265065180	5.76	34.53	26.59	-			
M205065150		4.13	20.11	16.09	-	M265065200	6.43	39.92	31.32	-			
M205065160		4.41	22.48	17.99	-	M265065220	7.03	45.16	36.72	-			
M205065170		4.67	24.85	19.59	-	M265065250	8.03	54.70	43.12	-			
M205065180		4.96	26.28	21.02	-	M265065270	8.70	59.96	47.27	-			
M205065200		5.53	30.22	24.17	-								
M205065220		6.05	34.34	27.47	-								
M205065250		6.91	40.22	32.17	38.94								
M205065270		7.49	44.00	35.20	41.82								
M235065130		3.86	18.35	14.67	-								
M235065140		4.14	21.15	16.92	-								
M235065150	4.45	24.00	19.20	-									
M235065160	4.76	26.77	21.42	-									
M235065170	5.04	29.13	23.30	-									
M235065180	5.35	31.77	25.42	-									
M235065200	5.97	36.36	29.07	-									
M235065220	6.53	41.46	34.97	-									
M235065250	7.46	48.65	41.04	-									

- indicates the load to produce a deflection of span/150 exceeds ultimate UDL capacity

Span (m)	Siderail Section	Weight kg/m	Ultimate Uniformly Distributed Load (kN)		Working Load to Produce Deflection of Span/150
			Pressure	Suction	
7.0	M175065120	3.02	10.15	8.12	9.70
	M175065130	3.29	11.85	9.48	10.50
	M175065140	3.52	13.60	10.88	11.29
	M175065150	3.79	15.19	12.15	12.08
	M175065160	4.05	16.51	13.21	12.86
	M175065180	4.55	19.88	15.91	14.41
	M175065200	5.08	22.65	18.12	15.93
	M175065220	5.56	25.66	20.53	17.44
	M175065250	6.35	29.94	23.95	19.65
	M205065120	3.29	11.56	9.25	-
	M205065130	3.58	13.51	10.81	-
	M205065140	3.84	15.52	12.41	-
	M205065150	4.13	17.55	14.04	17.55
	M205065160	4.41	19.59	15.67	18.69
	M205065170	4.67	21.62	17.05	19.84
	M205065180	4.96	22.84	18.27	20.94
	M205065200	5.53	26.21	20.97	23.17
	M205065220	6.05	29.74	23.79	25.37
	M205065250	6.91	34.78	27.82	28.61
	M205065270	7.49	38.02	30.41	30.72
	M235065130	3.86	16.15	12.92	-
	M235065140	4.14	18.56	14.85	-
	M235065150	4.45	21.01	16.81	-
	M235065160	4.76	23.11	18.71	-
	M235065170	5.04	25.41	20.32	-
	M235065180	5.35	27.67	22.14	-
	M235065200	5.97	31.60	25.27	-
	M235065220	6.53	35.97	30.34	35.16
	M235065250	7.46	42.13	35.54	39.67
	M235065270	8.08	46.11	38.90	42.62
	M265065140	4.46	21.07	16.84	-
	M265065150	4.79	24.74	19.58	-
M265065160	5.13	26.68	21.32	-	
M265065180	5.76	32.34	25.27	-	
M265065200	6.43	37.34	29.69	-	
M265065220	7.03	42.20	34.31	-	
M265065250	8.03	51.07	40.26	-	
M265065270	8.70	55.95	44.11	-	
7.5	M175065120	3.02	9.47	7.64	8.45
	M175065130	3.29	11.06	8.91	9.14
	M175065140	3.52	12.69	10.22	9.84
	M175065150	3.79	14.18	11.41	10.52
	M175065160	4.05	15.41	12.39	11.20
	M175065180	4.55	18.56	14.91	12.55
	M175065200	5.08	21.14	16.98	13.88
	M175065220	5.56	23.94	19.22	15.19
	M175065250	6.35	27.95	22.42	17.11
	M205065120	3.29	10.90	8.72	-
	M205065130	3.58	12.72	10.18	-
	M205065140	3.84	14.60	11.68	14.29
	M205065150	4.13	16.49	13.20	15.29
	M205065160	4.41	18.40	14.72	16.28
	M205065170	4.67	20.30	16.00	17.28
	M205065180	4.96	21.43	17.14	18.25
	M205065200	5.53	24.58	19.66	20.19
	M205065220	6.05	27.87	22.30	22.10
	M205065250	6.91	32.58	26.06	24.92
	M205065270	7.49	35.60	28.47	26.76
	M235065130	3.86	15.23	12.18	-
	M235065140	4.14	17.48	13.99	-

Span (m)	Siderail Section	Weight kg/m	Ultimate Uniformly Distributed Load (kN)		Working Load to Produce Deflection of Span/150
			Pressure	Suction	
8.0	M235065150	4.45	19.77	15.82	-
	M235065160	4.76	21.57	17.60	-
	M235065170	5.04	23.87	19.10	-
	M235065180	5.35	25.93	20.79	25.27
	M235065200	5.97	29.65	23.71	27.97
	M235065220	6.53	33.73	28.46	30.63
	M235065250	7.46	39.48	33.31	34.56
	M235065270	8.08	43.20	36.44	37.13
	M265065140	4.46	19.87	15.88	-
	M265065150	4.79	23.31	18.45	-
	M265065160	5.13	25.11	20.07	-
	M265065180	5.76	30.40	24.06	-
	M265065200	6.43	35.07	27.88	-
	M265065220	7.03	39.60	32.20	-
	M265065250	8.03	47.88	37.75	46.18
	M265065270	8.70	52.44	41.34	49.64
	M205065120	3.29	10.31	8.25	-
	M205065130	3.58	12.02	9.61	11.67
	M205065140	3.84	13.78	11.02	12.56
	M205065150	4.13	15.56	12.45	13.43
	M205065160	4.41	17.34	13.88	14.31
	M205065170	4.67	19.13	15.08	15.19
	M205065180	4.96	20.19	16.15	16.04
	M205065200	5.53	23.14	18.51	17.74
	M205065220	6.05	26.23	20.98	19.42
	M205065250	6.91	30.63	24.50	21.90
	M205065270	7.49	33.47	26.77	23.52
	M235065130	3.86	14.41	11.52	-
	M235065140	4.14	16.52	13.22	-
	M235065150	4.45	18.66	14.93	18.60
	M235065160	4.76	20.22	16.60	19.81
	M235065170	5.04	22.52	18.01	21.00
M235065180	5.35	24.31	19.60	22.21	
M235065200	5.97	27.93	22.33	24.58	
M235065220	6.53	31.75	26.79	26.92	
M235065250	7.46	37.14	31.33	30.38	
M235065270	8.08	40.63	34.27	32.63	
M265065140	4.46	18.80	15.03	-	
M265065150	4.79	22.03	17.44	-	
M265065160	5.13	23.72	18.96	-	
M265065180	5.76	28.68	22.95	-	
M265065200	6.43	33.05	26.28	32.82	
M265065220	7.03	37.31	30.33	35.96	
M265065250	8.03	45.07	35.53	40.59	
M265065270	8.70	49.34	38.90	43.62	

- indicates the load to produce a deflection of span/150 exceeds ultimate UDL capacity

Multibeam Cladding Rails - Load Tables

Table 3:6 Double Span Siderails (Vertical Cladding)

Span (m)	Siderail Section	Weight kg/m	Ultimate Uniformly Distributed Load (kN)		Working Load to Produce Deflection of Span/150	Span (m)	Siderail Section	Weight kg/m	Ultimate Uniformly Distributed Load (kN)		Working Load to Produce Deflection of Span/150	
			Pressure	Suction					Pressure	Suction		
8.5	M205065120	3.29	9.77	7.82	9.55	9.5	M235065130	3.86	12.31	9.91	11.45	
	M205065130	3.58	11.39	9.11	10.34		M235065140	4.14	14.10	11.34	12.32	
	M205065140	3.84	13.04	10.43	11.12		M235065150	4.45	15.90	12.79	13.19	
	M205065150	4.13	14.72	11.78	11.90		M235065160	4.76	17.03	14.20	14.05	
	M205065160	4.41	16.40	13.12	12.67		M235065170	5.04	19.14	15.38	14.90	
	M205065170	4.67	18.08	14.26	13.46		M235065180	5.35	20.47	16.72	15.75	
	M205065180	4.96	19.08	15.26	14.21		M235065200	5.97	23.70	19.02	17.43	
	M205065200	5.53	21.85	17.48	15.72		M235065220	6.53	26.92	22.78	19.09	
	M205065220	6.05	24.76	19.81	17.21		M235065250	7.46	31.46	26.61	21.54	
	M205065250	6.91	28.91	23.12	19.40		M235065270	8.08	34.39	29.08	23.14	
	M205065270	7.49	31.57	25.26	20.84		M265065140	4.46	16.07	12.93	-	
	M235065130	3.86	13.66	10.93	-		M265065150	4.79	18.81	14.97	17.59	
	M235065140	4.14	15.66	12.53	15.39		M265065160	5.13	20.22	16.24	18.74	
	M235065150	4.45	17.68	14.14	16.47		M265065180	5.76	24.41	19.77	21.02	
	M235065160	4.76	19.03	15.72	17.54		M265065200	6.43	28.08	22.41	23.28	
	M235065170	5.04	21.30	17.04	18.61		M265065220	7.03	31.66	25.83	25.50	
	M235065180	5.35	22.88	18.54	19.67		M265065250	8.03	38.21	30.20	28.78	
	M235065200	5.97	26.40	21.11	21.78		M265065270	8.70	41.80	33.04	30.94	
	M235065220	6.53	29.99	25.31	23.85		10.0	M235065130	3.86	11.69	9.46	10.33
	M235065250	7.46	35.07	29.58	26.91		M235065140	4.14	13.39	10.82	11.12	
	M235065270	8.08	38.34	32.35	28.91		M235065150	4.45	15.11	12.20	11.90	
	M265065140	4.46	17.84	14.26	-		M235065160	4.76	16.18	13.54	12.68	
	M265065150	4.79	20.88	16.53	-		M235065170	5.04	18.19	14.66	13.44	
	M265065160	5.13	22.47	17.96	-		M235065180	5.35	19.45	15.94	14.21	
	M265065180	5.76	27.14	21.89	26.26		M235065200	5.97	22.52	18.12	15.73	
	M265065200	6.43	31.26	24.85	29.07		M235065220	6.53	25.58	21.70	17.23	
	M265065220	7.03	35.26	28.66	31.85		M235065250	7.46	29.89	25.33	19.44	
	M265065250	8.03	42.57	33.56	35.96		M235065270	8.08	32.68	27.68	20.89	
M265065270	8.70	46.59	36.73	38.64	M265065140	4.46	15.27	12.35	14.83			
9.0	M205065120	3.29	9.29	7.44	8.52	M265065150	4.79	17.87	14.29	15.88		
	M205065130	3.58	10.82	8.65	9.22	M265065160	5.13	19.21	15.50	16.91		
	M205065140	3.84	12.38	9.91	9.92	M265065180	5.76	23.19	18.85	18.97		
	M205065150	4.13	13.97	11.18	10.61	M265065200	6.43	26.68	21.36	21.01		
	M205065160	4.41	15.56	12.45	11.30	M265065220	7.03	30.08	24.61	23.01		
	M205065170	4.67	17.15	13.52	12.00	M265065250	8.03	36.30	28.77	25.98		
	M205065180	4.96	18.08	14.47	12.67	M265065270	8.70	39.71	31.46	27.92		
	M205065200	5.53	20.70	16.56	14.02							
	M205065220	6.05	23.45	18.76	15.35							
	M205065250	6.91	27.37	21.89	17.31							
	M205065270	7.49	29.88	23.90	18.59							
	M235065130	3.86	12.99	10.39	12.76							
	M235065140	4.14	14.88	11.90	13.73							
	M235065150	4.45	16.79	13.43	14.69							
	M235065160	4.76	17.98	14.92	15.65							
	M235065170	5.04	20.21	16.17	16.60							
	M235065180	5.35	21.61	17.58	17.55							
	M235065200	5.97	25.02	20.01	19.42							
	M235065220	6.53	28.42	23.98	21.27							
	M235065250	7.46	33.21	28.02	24.00							
	M235065270	8.08	36.30	30.63	25.79							
	M265065140	4.46	16.97	13.56	-							
	M265065150	4.79	19.85	15.71	19.60							
	M265065160	5.13	21.34	17.06	20.88							
	M265065180	5.76	25.76	20.78	23.42							
	M265065200	6.43	29.64	23.57	25.93							
	M265065220	7.03	33.42	27.17	28.41							
	M265065250	8.03	40.33	31.79	32.07							
M265065270	8.70	44.12	34.78	34.47								

- indicates the load to produce a deflection of span/150 exceeds ultimate UDL capacity

Horizontal Panel Vertical Support Member (G140/150)

Span (m)	Ultimate Pressure Kn	Ultimate Suction Kn	Deflection L/150 Kn
3.0	23.44	9.21	9.10
3.5	19.66	7.72	6.69
4.0	16.73	6.58	5.12
4.5	14.33	6.68	4.05

Table 3:7 Multibeam Cladding Rails (Horizontal Cladding)

Span (m)	Siderail Section	Weight kg/m	Ultimate Uniformly Distributed Load (kN)		Working Load to Produce Deflection of Span/150	Span (m)	Siderail Section	Weight kg/m	Ultimate Uniformly Distributed Load (kN)		Working Load to Produce Deflection of Span/150
			Pressure	Suction					Pressure	Suction	
4.0	M145065120	2.75	14.96	14.96	22.21	5.5	M145065120	2.75	11.89	11.89	11.75
	M145065130	2.99	17.16	17.16	24.03		M145065130	2.99	13.49	13.49	12.71
	M145065140	3.21	19.36	19.36	25.84		M145065140	3.21	14.94	14.94	13.67
	M145065150	3.45	21.54	21.54	27.64		M145065150	3.45	16.23	16.23	14.62
	M145065160	3.69	23.70	23.70	29.42		M145065160	3.69	17.48	17.48	15.56
	M145065180	4.15	27.96	27.96	32.94		M145065180	4.15	19.97	19.97	17.42
	M145065200	4.63	32.12	32.12	36.41		M145065200	4.63	22.35	22.35	19.26
	M145065220	5.06	36.20	36.20	39.81		M145065220	5.06	24.61	24.61	21.06
	M175065120	3.02	16.18	16.18	34.45		M175065120	3.02	13.27	13.27	18.22
	M175065130	3.29	18.94	18.94	37.29		M175065130	3.29	15.33	15.33	19.72
	M175065140	3.52	21.74	21.74	40.11		M175065140	3.52	17.41	17.41	21.22
	M175065150	3.79	24.57	24.57	42.90		M175065150	3.79	19.47	19.47	22.69
	M175065160	4.05	27.39	27.39	45.68		M175065160	4.05	21.11	21.11	24.16
	M175065180	4.55	32.99	32.99	51.18		M175065180	4.55	24.29	24.29	27.07
	M175065200	5.08	38.49	38.49	56.60		M175065200	5.08	27.38	27.38	29.94
	M175065220	5.56	43.86	43.86	61.93		M175065220	5.56	30.22	30.22	32.76
	M175065250	6.35	51.73	51.73	69.79		M175065250	6.35	34.38	34.38	36.91
	4.5	M145065120	2.75	13.79	13.79		17.55	M205065120	3.29	13.99	13.99
M145065130		2.99	15.75	15.75	18.99	M205065130	3.58	16.48	16.48	28.64	
M145065140		3.21	17.70	17.70	20.42	M205065140	3.84	19.01	19.01	30.81	
M145065150		3.45	19.63	19.63	21.84	M205065150	4.13	21.57	21.57	32.97	
M145065160		3.69	21.55	21.55	23.24	M205065160	4.41	24.13	24.13	35.11	
M145065180		4.15	25.31	25.31	26.02	M205065170	4.67	26.44	26.44	37.28	
M145065200		4.63	28.89	28.89	28.77	M205065180	4.96	28.36	28.36	39.35	
M145065220		5.06	32.03	32.03	31.46	M205065200	5.53	32.18	32.18	43.54	
M175065120		3.02	15.08	15.08	27.22	M205065220	6.05	35.72	35.72	47.67	
M175065130		3.29	17.58	17.58	29.46	M205065250	6.91	40.78	40.78	53.75	
M175065140		3.52	20.09	20.09	31.69	M205065270	7.49	44.03	44.03	57.73	
M175065150		3.79	22.62	22.62	33.90	M175065120	3.02	12.50	12.50	15.31	
M175065160		4.05	25.12	25.12	36.09	M175065130	3.29	14.24	14.24	16.57	
M175065180		4.55	30.09	30.09	40.44	M175065140	3.52	15.68	15.68	17.83	
M175065200		5.08	34.96	34.96	44.72	M175065150	3.79	17.10	17.10	19.07	
M175065220		5.56	39.59	39.59	48.94	M175065160	4.05	18.48	18.48	20.30	
M175065250		6.35	45.52	45.52	55.14	M175065180	4.55	21.03	21.03	22.75	
5.0		M145065120	2.75	12.77	12.77	14.21	M175065200	5.08	23.51	23.51	25.16
	M145065130	2.99	14.54	14.54	15.38	M175065220	5.56	25.92	25.92	27.53	
	M145065140	3.21	16.29	16.29	16.54	M175065250	6.35	29.45	29.45	31.02	
	M145065150	3.45	18.02	18.02	17.69	M205065120	3.29	13.28	13.28	22.23	
	M145065160	3.69	19.74	19.74	18.83	M205065130	3.58	15.60	15.60	24.06	
	M145065180	4.15	22.67	22.67	21.08	M205065140	3.84	17.91	17.91	25.89	
	M145065200	4.63	25.46	25.46	23.30	M205065150	4.13	19.66	19.66	27.70	
	M145065220	5.06	28.19	28.19	25.48	M205065160	4.41	21.38	21.38	29.50	
	M175065120	3.02	14.12	14.12	22.05	M205065170	4.67	23.02	23.02	31.32	
	M175065130	3.29	16.39	16.39	23.86	M205065180	4.96	24.53	24.53	33.07	
	M175065140	3.52	18.66	18.66	25.67	M205065200	5.53	27.53	27.53	36.59	
	M175065150	3.79	20.94	20.94	27.46	M205065220	6.05	30.45	30.45	40.06	
	M175065160	4.05	23.19	23.19	29.24	M205065250	6.91	34.69	34.69	45.17	
	M175065180	4.55	27.64	27.64	32.76	M205065270	7.49	37.43	37.43	48.51	
	M175065200	5.08	31.26	31.26	36.23	M235065130	3.86	16.17	16.17	33.30	
	M175065220	5.56	34.75	34.75	39.64	M235065140	4.14	18.90	18.90	35.83	
	M175065250	6.35	39.86	39.86	44.67	M235065150	4.45	21.69	21.69	38.35	
	M205065120	3.29	14.76	14.76	32.01	M235065160	4.76	23.92	23.92	40.84	
M205065130	3.58	17.45	17.45	34.65	M235065170	5.04	25.91	25.91	43.31		
M205065140	3.84	20.21	20.21	37.28	M235065180	5.35	27.76	27.76	45.80		
M205065150	4.13	23.01	23.01	39.89	M235065200	5.97	31.34	31.34	50.69		
M205065160	4.41	25.83	25.83	42.48	M235065220	6.53	34.78	34.78	55.52		
M205065170	4.67	28.66	28.66	45.11	M235065250	7.46	39.76	39.76	62.64		
M205065180	4.96	31.44	31.44	47.62	M235065270	8.08	42.96	42.96	67.30		
M205065200	5.53	36.81	36.81	52.69							
M205065220	6.05	41.17	41.17	57.68							
M205065250	6.91	47.50	47.50	65.04							
M205065270	7.49	51.44	51.44	69.85							

Multibeam Cladding Rails - Load Tables

Table 3:7 Multibeam Cladding Rails (Horizontal Cladding) (Cont.)

Span (m)	Siderail Section	Weight kg/m	Ultimate Uniformly Distributed Load (kN)		Working Load to Produce Deflection of Span/150	Span (m)	Siderail Section	Weight kg/m	Ultimate Uniformly Distributed Load (kN)		Working Load to Produce Deflection of Span/150		
			Pressure	Suction					Pressure	Suction			
6.0	M175065120	3.02	10.33	10.33	14.08	6.5	M175065120	3.02	9.73	9.73	12.00		
	M175065130	3.29	11.89	11.89	15.24		M175065130	3.29	11.15	11.15	12.99		
	M175065140	3.52	17.06	17.06	16.40		M175065140	3.52	15.98	15.98	13.97		
	M175065150	3.79	18.96	18.96	17.54		M175065150	3.79	17.73	17.73	14.94		
	M175065160	4.05	20.83	20.83	18.67		M175065160	4.05	19.44	19.44	15.91		
	M175065180	4.55	24.49	24.49	20.92		M175065180	4.55	22.15	22.15	17.83		
	M175065200	5.08	27.52	27.52	23.14		M175065200	5.08	24.75	24.75	19.71		
	M175065220	5.56	30.37	30.37	25.32		M175065220	5.56	27.29	27.29	21.57		
	M175065250	6.35	34.56	34.56	28.53		M175065250	6.35	31.04	31.04	24.31		
	M205065120	3.29	10.88	10.88	20.44		M205065120	3.29	10.36	10.36	17.42		
	M205065130	3.58	12.82	12.82	22.13		M205065130	3.58	12.15	12.15	18.86		
	M205065140	3.84	14.77	14.77	23.81		M205065140	3.84	13.93	13.93	20.29		
	M205065150	4.13	16.71	16.71	25.48		M205065150	4.13	15.70	15.70	21.71		
	M205065160	4.41	18.62	18.62	27.13		M205065160	4.41	17.45	17.45	23.12		
	M205065170	4.67	20.53	20.53	28.81		M205065170	4.67	19.19	19.19	24.55		
	M205065180	4.96	28.45	28.45	30.41		M205065180	4.96	26.51	26.51	25.92		
	M205065200	5.53	33.00	33.00	33.65		M205065200	5.53	29.67	29.67	28.67		
	M205065220	6.05	36.62	36.62	36.84		M205065220	6.05	32.79	32.79	31.39		
	M205065250	6.91	41.77	41.77	41.54		M205065250	6.91	37.38	37.38	35.39		
	M205065270	7.49	45.13	45.13	44.61		M205065270	7.49	40.36	40.36	38.01		
	M235065130	3.86	13.13	13.13	30.62		M235065130	3.86	12.57	12.57	26.09		
	M235065140	4.14	15.43	15.43	32.96		M235065140	4.14	14.70	14.70	28.08		
	M235065150	4.45	17.77	17.77	35.27		M235065150	4.45	16.85	16.85	30.05		
	M235065160	4.76	20.11	20.11	37.56		M235065160	4.76	19.00	19.00	32.01		
	M235065170	5.04	22.45	22.45	39.84		M235065170	5.04	21.14	21.14	33.94		
	M235065180	5.35	24.77	24.77	42.12		M235065180	5.35	23.26	23.26	35.89		
	M235065200	5.97	29.32	29.32	46.62		M235065200	5.97	34.61	34.61	39.73		
	M235065220	6.53	33.73	33.73	51.06		M235065220	6.53	38.32	38.32	43.51		
	M235065250	7.46	49.10	49.10	57.61		M235065250	7.46	43.76	43.76	49.09		
	M235065270	8.08	53.11	53.11	61.89		M235065270	8.08	47.31	47.31	52.74		
	6.5	M175065120	3.02	11.24	11.24		13.04	7.0	M205065120	3.29	9.87	9.87	15.02
		M175065130	3.29	12.47	12.47		14.12		M205065130	3.58	11.52	11.52	16.26
M175065140		3.52	13.60	13.60	15.19	M205065140	3.84		13.17	13.17	17.50		
M175065150		3.79	14.72	14.72	16.25	M205065150	4.13		14.80	14.80	18.72		
M175065160		4.05	15.81	15.81	17.30	M205065160	4.41		20.84	20.84	19.93		
M175065180		4.55	17.96	17.96	19.38	M205065170	4.67		22.30	22.30	21.17		
M175065200		5.08	20.05	20.05	21.43	M205065180	4.96		23.70	23.70	22.34		
M175065220		5.56	22.09	22.09	23.45	M205065200	5.53		26.52	26.52	24.72		
M175065250		6.35	25.10	25.10	26.43	M205065220	6.05		29.30	29.30	27.07		
M205065120		3.29	12.63	12.63	18.94	M205065250	6.91		33.38	33.38	30.52		
M205065130		3.58	14.18	14.18	20.51	M205065270	7.49		35.96	35.96	32.78		
M205065140		3.84	15.60	15.60	22.06	M235065130	3.86		12.03	12.03	22.50		
M205065150		4.13	16.95	16.95	23.60	M235065140	4.14		14.01	14.01	24.21		
M205065160		4.41	18.28	18.28	25.14	M235065150	4.45		16.00	16.00	25.91		
M205065170		4.67	19.62	19.62	26.69	M235065160	4.76		17.98	17.98	27.60		
M205065180		4.96	20.86	20.86	28.18	M235065170	5.04		19.95	19.95	29.27		
M205065200		5.53	23.36	23.36	31.18	M235065180	5.35		27.47	27.47	30.95		
M205065220		6.05	25.81	25.81	34.13	M235065200	5.97		30.81	30.81	34.25		
M205065250		6.91	29.37	29.37	38.48	M235065220	6.53		34.09	34.09	37.52		
M205065270		7.49	31.69	31.69	41.33	M235065250	7.46		38.92	38.92	42.33		
M235065130		3.86	15.45	15.45	28.37	M235065270	8.08		42.03	42.03	45.47		
M235065140		4.14	17.34	17.34	30.53								
M235065150		4.45	18.96	18.96	32.67								
M235065160		4.76	20.53	20.53	34.80								
M235065170		5.04	22.06	22.06	36.90								
M235065180		5.35	23.58	23.58	39.02								
M235065200		5.97	26.53	26.53	43.19								
M235065220		6.53	29.37	29.37	47.30								
M235065250		7.46	33.51	33.51	53.37								
M235065270		8.08	36.19	36.19	57.34								

Span (m)	Siderail Section	Weight kg/m	Ultimate Uniformly Distributed Load (kN)		Working Load to Produce Deflection of Span/150
			Pressure	Suction	
7.5	M205065120	3.29	9.42	9.42	13.08
	M205065130	3.58	10.95	10.95	14.17
	M205065140	3.84	12.47	12.47	15.24
	M205065150	4.13	17.30	17.30	16.31
	M205065160	4.41	18.59	18.59	17.37
	M205065170	4.67	19.90	19.90	18.44
	M205065180	4.96	21.14	21.14	19.47
	M205065200	5.53	23.66	23.66	21.54
	M205065220	6.05	26.13	26.13	23.58
	M205065250	6.91	29.58	29.58	26.59
	M205065270	7.49	31.81	31.81	28.55
	M235065120	3.55	9.72	9.72	18.10
	M235065130	3.86	11.53	11.53	19.60
	M235065140	4.14	13.37	13.37	21.09
	M235065150	4.45	15.22	15.22	22.57
	M235065160	4.76	21.40	21.40	24.04
	M235065170	5.04	22.89	22.89	25.50
	M235065180	5.35	24.40	24.40	26.96
	M235065200	5.97	27.37	27.37	29.84
	M235065220	6.53	30.28	30.28	32.68
M235065250	7.46	34.38	34.38	36.87	
M235065270	8.08	36.98	36.98	39.61	
8.0	M235065120	3.55	9.35	9.35	15.91
	M235065130	3.86	11.06	11.06	17.23
	M235065140	4.14	12.78	12.78	18.54
	M235065150	4.45	17.65	17.65	19.84
	M235065160	4.76	18.99	18.99	21.13
	M235065170	5.04	20.32	20.32	22.41
	M235065180	5.35	21.66	21.66	23.69
	M235065200	5.97	24.28	24.28	26.23
	M235065220	6.53	26.69	26.69	28.72
	M235065250	7.46	30.20	30.20	32.41
	M235065270	8.08	32.47	32.47	34.82
	M265065120	3.82	9.34	9.34	21.21
	M265065130	4.16	11.25	11.25	22.98
	M265065140	4.46	13.22	13.22	24.73
	M265065150	4.79	15.23	15.23	26.47
	M265065160	5.13	21.34	21.34	28.19
	M265065180	5.76	24.40	24.40	31.63
	M265065200	6.43	27.43	27.43	35.02
	M265065220	7.03	30.25	30.25	38.36
	M265065250	8.03	34.26	34.26	43.30
M265065270	8.70	36.86	36.86	46.54	
8.0	M235065120	3.55	8.39	8.39	13.67
	M235065130	3.86	9.90	9.90	14.80
	M235065140	4.14	11.44	11.44	15.92
	M235065150	4.45	12.97	12.97	17.04
	M235065160	4.76	14.50	14.50	18.15
	M235065170	5.04	16.01	16.01	19.25
	M235065180	5.35	22.19	22.19	20.35
	M235065200	5.97	24.97	24.97	22.53
	M235065220	6.53	27.72	27.72	24.67
	M235065250	7.46	31.73	31.73	27.83
	M235065270	8.08	34.16	34.16	29.91
	M265065120	3.82	8.39	8.39	18.22
	M265065130	4.16	10.09	10.09	19.73
	M265065140	4.46	11.85	11.85	21.24
	M265065150	4.79	13.65	13.65	22.73
	M265065160	5.13	15.45	15.45	24.22
	M265065180	5.76	19.07	19.07	27.17
	M265065200	6.43	28.33	28.33	30.08
	M265065220	7.03	31.53	31.53	32.95
	M265065250	8.03	36.22	36.22	37.20
M265065270	8.70	39.13	39.13	39.98	

Restrains at 1/3 points

Restrains at 1/3 points

Restrains at 1/4 points

Span (m)	Siderail Section	Weight kg/m	Ultimate Uniformly Distributed Load (kN)		Working Load to Produce Deflection of Span/150
			Pressure	Suction	
9.0	M235065120	3.55	10.70	10.70	12.57
	M235065130	3.86	11.79	11.79	13.61
	M235065140	4.14	12.88	12.88	14.65
	M235065150	4.45	13.96	13.96	15.68
	M235065160	4.76	14.93	14.93	16.70
	M235065170	5.04	15.89	15.89	17.71
	M235065180	5.35	16.86	16.86	18.72
	M235065200	5.97	18.75	18.75	20.72
	M235065220	6.53	20.58	20.58	22.70
	M235065250	7.46	23.28	23.28	25.61
	M235065270	8.08	25.04	25.04	27.51
	M265065120	3.82	8.78	8.78	16.76
	M265065130	4.16	13.10	13.10	18.15
	M265065140	4.46	14.35	14.35	19.54
	M265065150	4.79	15.59	15.59	20.91
	M265065160	5.13	16.78	16.78	22.28
	M265065180	5.76	18.97	18.97	24.99
	M265065200	6.43	21.11	21.11	27.67
	M265065220	7.03	23.20	23.20	30.31
	M265065250	8.03	26.25	26.25	34.22
M265065270	8.70	28.22	28.22	36.77	
9.0	M235065130	3.86	9.52	9.52	13.20
	M235065140	4.14	10.97	10.97	14.20
	M235065150	4.45	12.41	12.41	15.20
	M235065160	4.76	13.84	13.84	16.19
	M235065170	5.04	18.91	18.91	17.17
	M235065180	5.35	20.21	20.21	18.15
	M235065200	5.97	22.74	22.74	20.09
	M235065220	6.53	25.25	25.25	22.01
	M235065250	7.46	28.63	28.63	24.83
	M235065270	8.08	30.81	30.81	26.68
	M265065140	4.46	11.43	11.43	18.95
	M265065150	4.79	13.12	13.12	20.28
	M265065160	5.13	14.82	14.82	21.60
	M265065180	5.76	22.80	22.80	24.23
	M265065200	6.43	25.74	25.74	26.83
	M265065220	7.03	28.64	28.64	29.39
	M265065250	8.03	32.66	32.66	33.18
	M265065270	8.70	35.16	35.16	35.66

Restrains at 1/3 points

Restrains at 1/4 points

Cladding Rails



MULTICHANNEL MODIFIED!

Lighter | Stiffer | Stronger | Greener



Multichannel

Overview	96
Why Multichannel?	97
Multichannel Restraints	98
Construction Details	104
Product Dimensions and References	114
Section Properties	122
Load Tables	123



L350/90



L300/90



L265/70



L235/70



L205/70



L175/70



L145/70

Multichannel - Overview

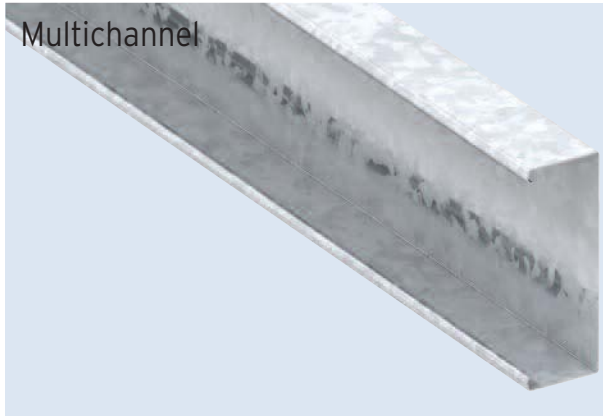

Applications

- Horizontally laid cladding rails
- Parapet posts
- Mezzanine floors
- Brickwork restraints
- Door and window trimmers, ribbon windows
- Wind bracing
- Columns
- Gable ends
- General engineering applications

Material Specification

Hot dip galvanised steel to BS EN 10326:2004 and BS EN 10143:1993 'specifications for continuously hot dip zinc/metal coated structural steel strip'.

The minimum grade of steel used is **S450GD**, with Z275 zinc coating, giving an average coating thickness of 0.02mm to each side. Other galvanised coatings may be available. Please contact our Technical Department for advice.

Sustainability

The Multibeam system has been engineered to ensure maximum performance whilst minimising the material content.

Individual sections are packed together using low carbon mild steel, blued and waxed banding which is wholly recyclable. Identification of the bundles is by paper labels which are biodegradable and can be recycled.

Softwood bearers, used to support the bundles in transport are from managed woodland and are reusable.

Reuse

Steel does not lose its strength or stiffness over time so remains a viable product for reuse. Assembly joints between components can be easily dismantled at any time to facilitate reuse. Sections can be recut to length and reholed to suit a revised use.

Recycling

Steel is one of the world's most recycled materials with over 40% of 'new' steel made from recycled steel. Kingspan's suppliers encourage, promote and assist in the return of steel for recycling.



Certification

Kingspan Structural Products has developed a fully integrated management system which combines all the common elements of **ISO 9001 (Quality)**, **ISO 14001 (Environment)** and **OHSAS 18001 (Occupational Health and Safety)** into one system. This simple coherent business management system enables the organisation to successfully achieve its purpose and mission to ensure that quality; safety and the environment are considered in all aspects of the business process. Further information on these certifications can be found on our website www.kingspanstructural.com.

Range

- Section heights from 145mm to 350mm
- Flange widths from 70mm to 90mm
- Gauges from 1.2mm to 2.7mm

For full product dimensions see page 114. Other sizes may be available on specific request. Please contact our Technical Department for advice.

Lengths

- All lengths are catered for; requirements in excess of 18m, please contact our Sales Department.

MULTICHANNEL MODIFIED!

“ Multichannel is now greener due to overall reduced steel content ”

Why Multichannel?

Multichannel sections offer lightweight robust construction and may be used in lieu of some hot rolled sections, offering easier site handling. Multichannel is suitable for a wide range of structural applications including horizontal cladding support, door and window trimmers, wind bracing, mezzanine floor beams, brickwork restraints, gable rafters and columns.

Autoform® Ends

The unique feature of the Multichannel system is the Autoform® End. Autoform® eliminates the need for fixing cleats and brackets which simplifies the construction process by providing numerous connection solutions to speed fabrication and on-site construction.

Autoforms® are available with the returns turned inward or outward and can be punched or counterformed with standard hole options as required.

Using this system, connections are primarily made using two bolts which halves the connection time in fabrication and also reduces fixing material costs.

Notches

Multichannel can be supplied with plain ends, notched ends (top, bottom or both) and/or with Autoform® Ends offering installation flexibility.

Counterform Holes

In order to provide a flush connection for door and window applications an off-line process of counterforming is used. This enables countersunk bolts to be used without compromising the finish of the Multichannel Rail.

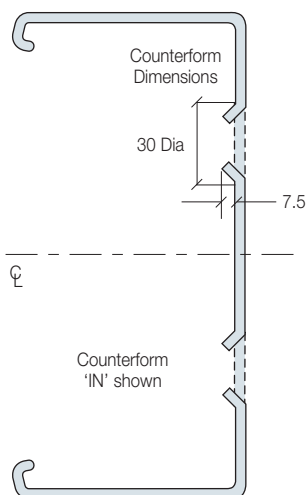

Autoform® In

Autoform® Out

Autoform® Notched Ends

Autoform® In

Autoform Ends remove the need for cleats and reduces the amount of components required on site.

Multichannel

Restraints - Vertically Laid Cladding

Restraints for Bays up to 6.1m

The single strut system is utilised on buildings with bays up to 6.1m centres with adjustable diagonal tie wire as shown in the diagram.

Bays up to 3.0m generally do not require vertical support struts.

This system is for use with cladding which, when fixed restrains the Multibeam siderail outer flange.

* When wall exceeds 10m in height allow one set of diagonal ties for every 9.0m of height.

Maximum rail cross centres are 2m. For larger cross centres, contact Kingspan technical.

Where the weight of the cladding is greater than 0.12 kN/m^2 please contact our Technical Department.

Where the insulated panel is only through fixed on one edge trapping an under tongue on the adjacent panel the restraint system on this page should be used, but with the bottom tube strut replaced with an angle strut and the diagonal tie wire replaced with a rod diagonal.

The strut system should be fitted between the bottom rails and the rails levelled before proceeding progressively upwards.

Where the cladding is clip fixed or fixed in such a way that the cladding can slip, relative to the side rail face please contact our Technical Department.

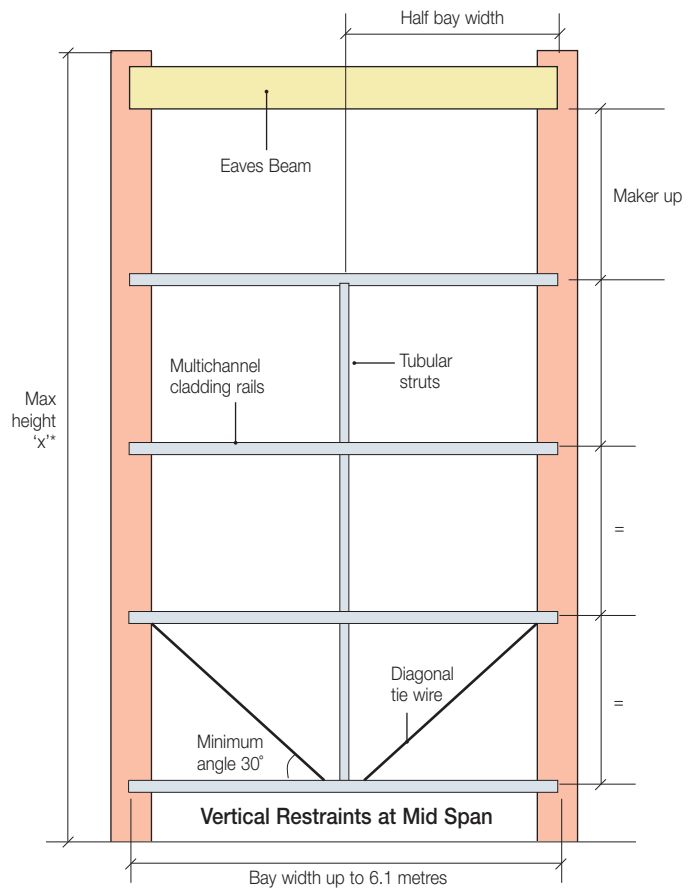

Restraints for Bays over 6.1m up to 9.0m

The double strut system is utilised on buildings with bays over 6.1m metres up to 9.0m.

* When wall exceeds 10m in height allow one set of diagonal ties for every 9.0m of height.

Where the insulated panel is only through fixed on one edge trapping an under tongue on the adjacent panel the restraint system shown on this page should be used, but with the bottom tube strut replaced with an angle strut and the diagonal tie wire replaced with a rod diagonal.

Where the cladding is clip fixed or fixed in such a way that the cladding can slip, relative to the side rail face please contact our Technical Department.

Maximum rail cross centres are 2m. For larger cross centres, contact Kingspan technical.

Where the weight of the cladding is greater than 0.12 kN/m^2 please contact our Technical Department.

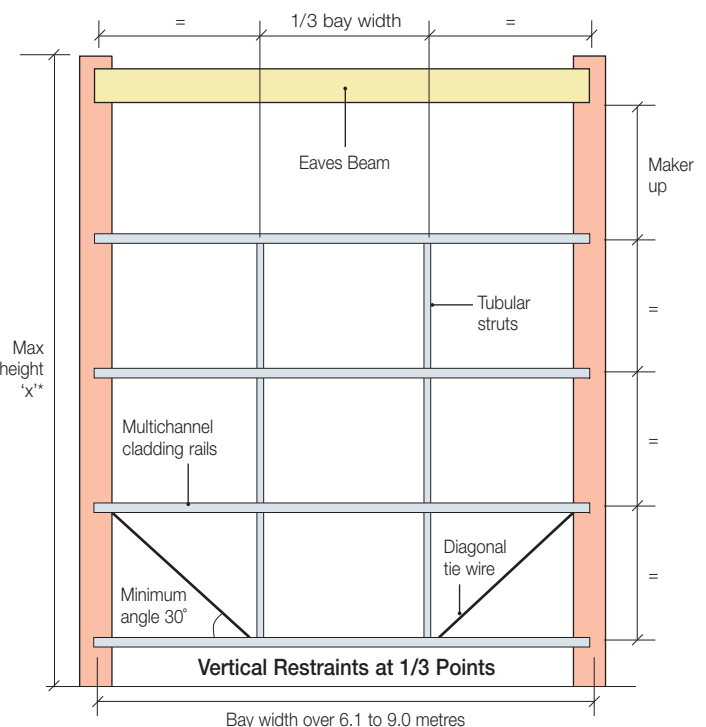

Bays over 9.0m

Bays over 9.0m are possible with Multichannel sections, for vertical restraints consult our Technical Department.

Restraints - Firewall

This assembly of Multichannel side rails is designed to offer lateral support to the cladding assembly, which provides the firewall performance of insulation integrity and stability for the periods derived from test or assessment. Periods up to 240 minutes are possible.

Firewall systems rely on the performance of the cladding. As the sheeting rails are relatively thin components they have very little heat sink capacity owing to their low mass. When subjected to a fire resistance test, the sheeting rails are heated very quickly and consequently lose their structural strength.

Sheeting rails whether exposed or concealed do retain sufficient strength to prevent the wall from significant lateral movement even after 240 minutes of exposure to a standard fire resistance test.

Sheeting rails with a minimum thickness of 1.2mm and above may be used for both twin skin cladding and composite panels, providing they are structurally capable of supporting the wall between the column spacings for the normal load case.

To reduce thermally induced stresses caused by expansion of the sheeting rails during the early stages of a fire, slotted holes are provided, in the ends of the horizontal sheeting rails. The rails are shortened in length and low temperature fusible washers are used so that thermally induced movement can occur unrestricted.

The cladding suppliers requirements should always be checked especially where special or unusual details are required.

Typical Restraints for Firewall at Mid-span

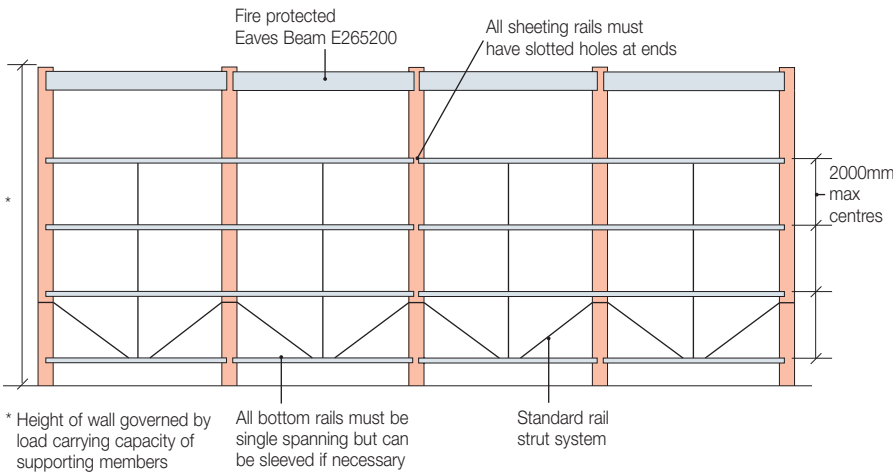

General Notes

1. Firewall rails should be 30mm shorter in length and should have 54mm x 14mm slotted holes to cater for expansion.
2. Although bottom rails must be single spanning to suit fire conditions, standard sleeves may be introduced to provide continuity for structural considerations.
3. At the discretion of the engineer, joints on rails may be staggered to provide uniform distribution of wind loadings to support structures.
4. Eaves Beam E265/200 is the only available section if supporting the weight of the wall and must be fire protected.

Firewall hole layout

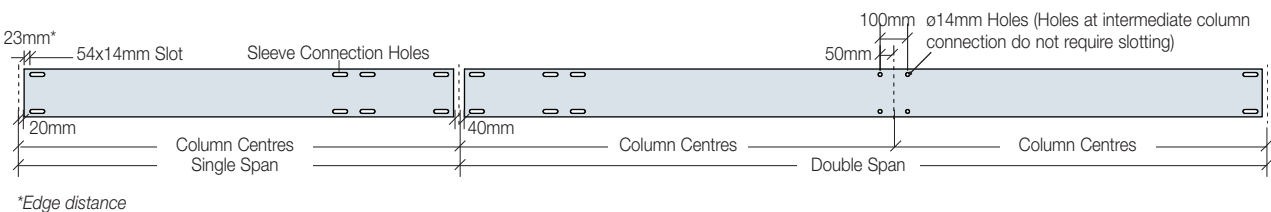

Restraints - Horizontally Laid Cladding

Cladding joints at Stanchions

This typical example also shows vertical restraint provided by standard diagonal tie wires and the connection to the Eaves Beam system.

Connection Details

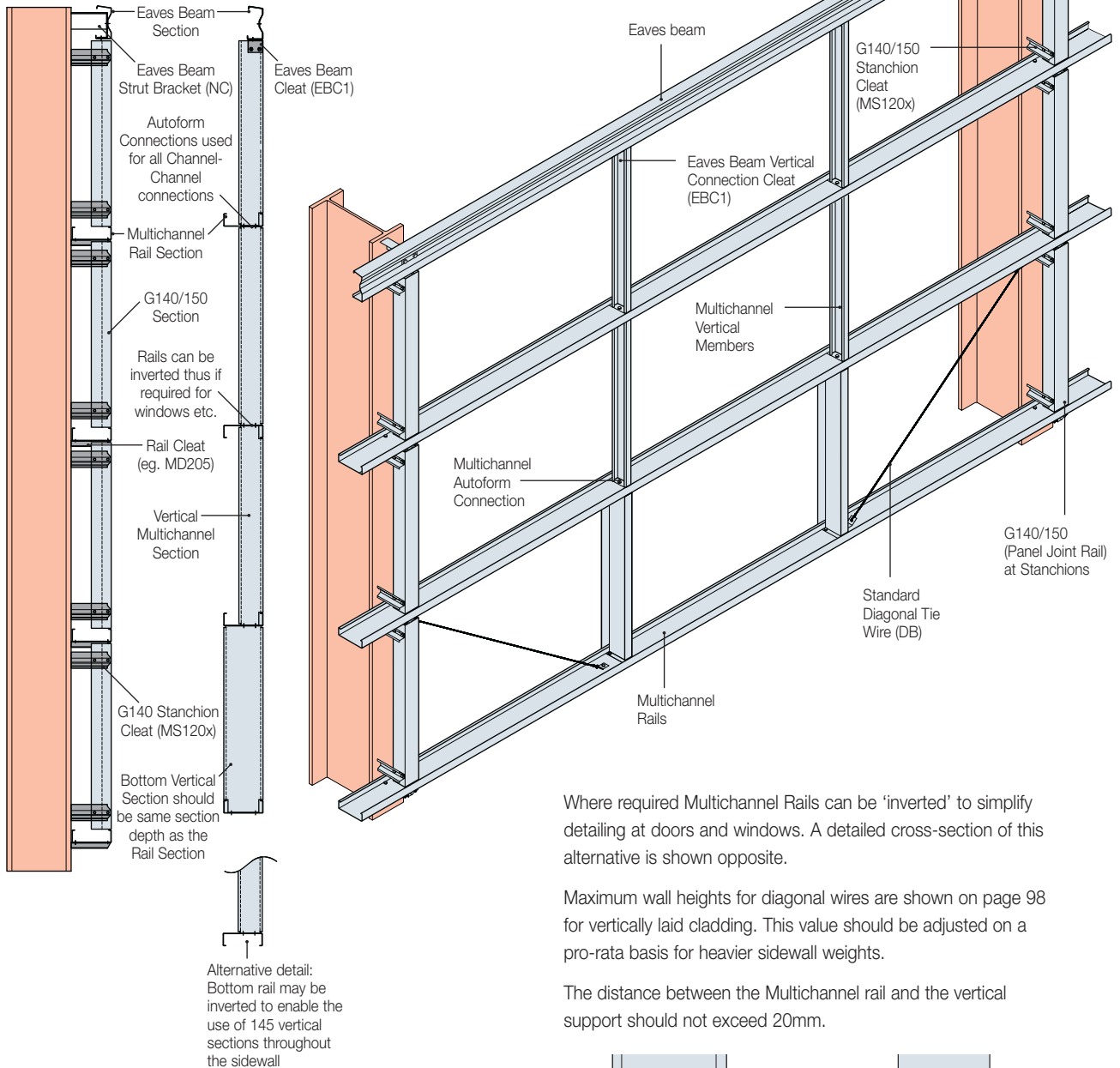

Where required Multichannel Rails can be 'inverted' to simplify detailing at doors and windows. A detailed cross-section of this alternative is shown opposite.

Maximum wall heights for diagonal wires are shown on page 98 for vertically laid cladding. This value should be adjusted on a pro-rata basis for heavier sidewall weights.

The distance between the Multichannel rail and the vertical support should not exceed 20mm.

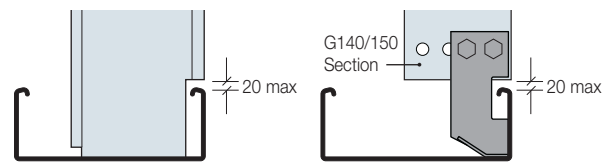

Cladding Joint Within Span

Where cladding is joined within the bay span a wider flange is required in order to 'butt' the panels together. For this detail a G140/150 section is used together with screwed rod diagonal.

Connection Details

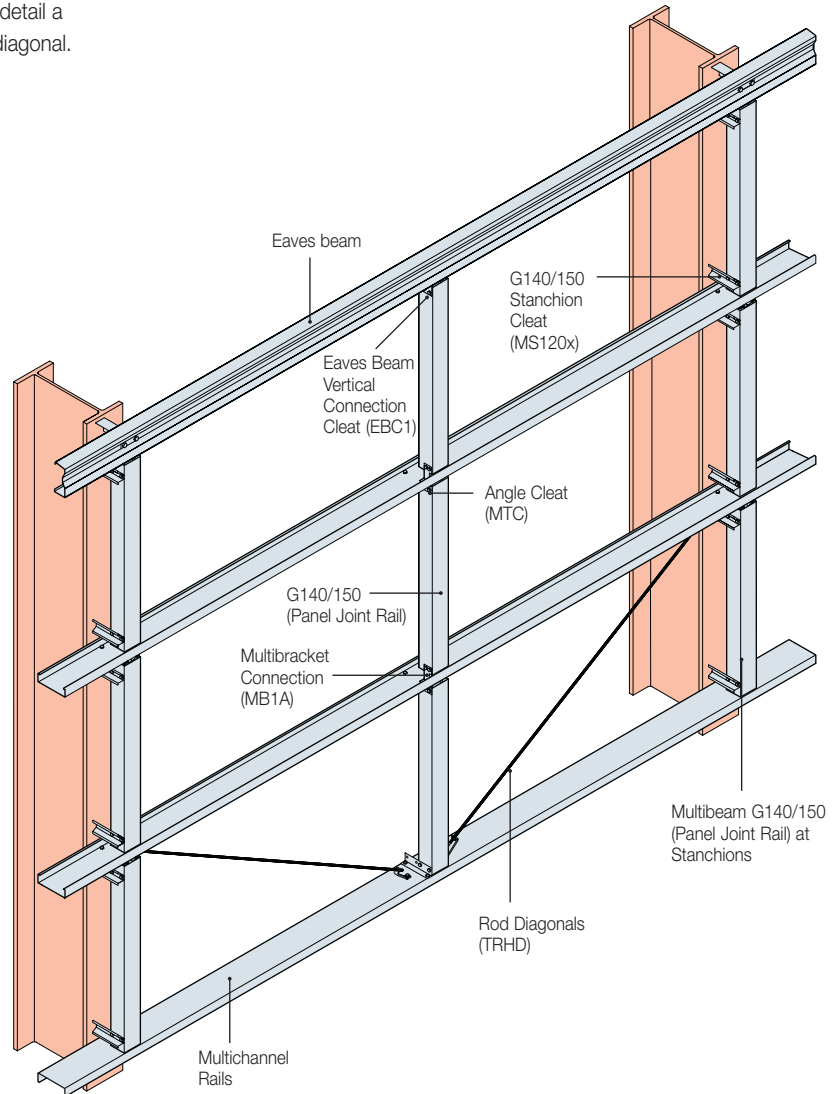
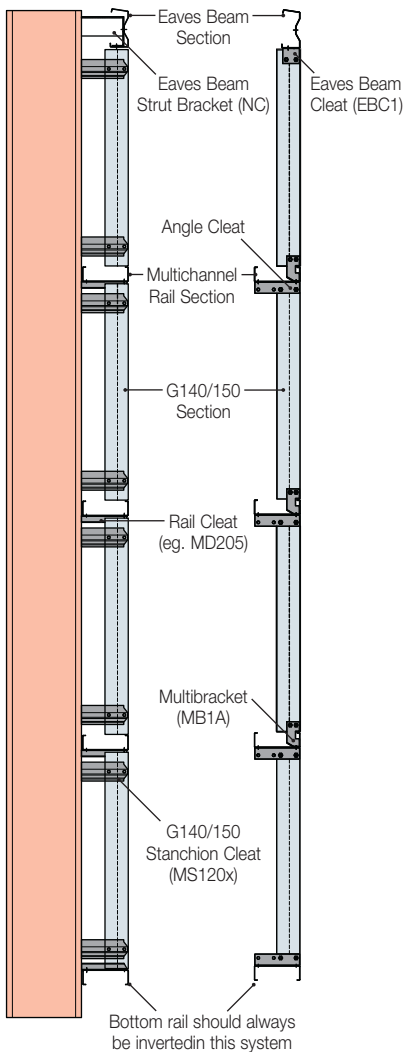

Horizontally laid cladding - Top Hat supports

Vertical top hat cladding supports provided by the sheeting contractor to support horizontally laid insulated panels - The restraints can be as shown on page 98 but the tube strut between the bottom pair of rails supporting the top hats must be replaced with a vertical Multichannel of the same depth of the rail and attached as shown on page 98. The standard tie wire must be replaced with a rod diagonal.

The top hats must be positioned at or very close to the rail restraint positions to avoid twisting of the horizontal member. The top hat section must be attached to all rails that it passes over using suitable fixings that can support the vertical dead loads and the wind pressure and suction loads.

Multichannel - Applications

Parapet Posts

Multichannel can be used as an efficient and economical parapet post section to support vertical or horizontally laid cladding on industrial and commercial buildings.

The Multichannel parapet post can be supplied as a kit for assembly on site or as a fully assembled component ready to attach to the main steelwork and complete with attachment cleats to suit Multichannel or Multibeam horizontal cladding rails.

Use the Toolkit design software to select sections against the applied wind loads and dead weights of the supported cladding.

For specific construction details please contact our Technical department.

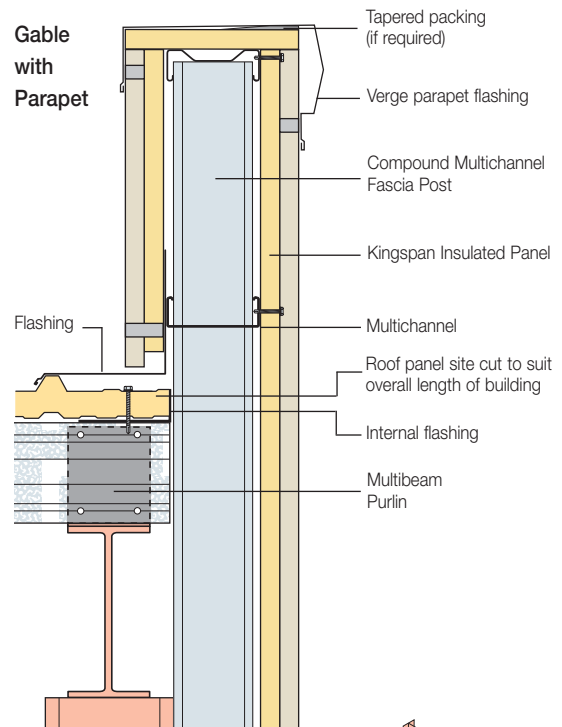

Door and Window Openings

In sidewall situations where openings are required, we recommend the use of Multichannel sections. These versatile sections provide an easy solution for door and window openings, trimmers etc. and section sizes are compatible with Multichannel cladding rail section sizes.

Where required Multichannels can be used as a substitute for Multibeam cladding rails as all components (eg. Cleats etc.) are fully compatible.

It must be noted however, that equivalent section sizes may not provide an identical performance and heavier gauges may be required. (see section properties on page 122).

Door Openings

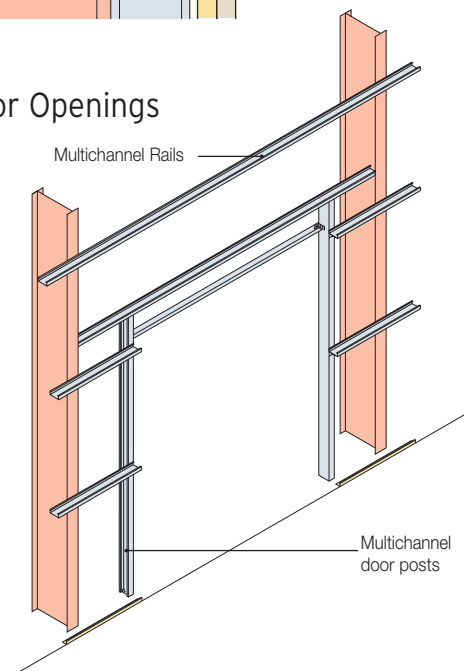

Window Openings

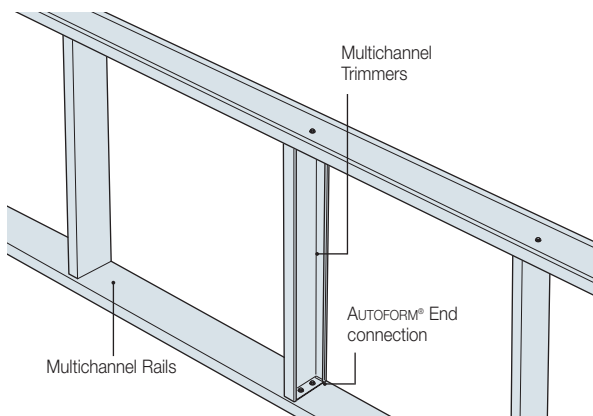

Window Trimmers

Mezzanine Floors

Multichannels can be used for primary or secondary floor beams in mezzanine floor applications. They can also be used singly or compounded to form columns, and can be used as stair rails and treads providing a completely pre-engineered mezzanine floor package.

Multichannel Mezzanine floor beams can be utilised with all popular types of flooring including checkerplate, timber etc. They can be fitted between steel or over steel supports either with or without cleats. Fitting over steelwork gives the economy of double span members but increases the depth of the floor structure.

Construction details are provided for all three systems, please see pages 111 and 112 for further information.

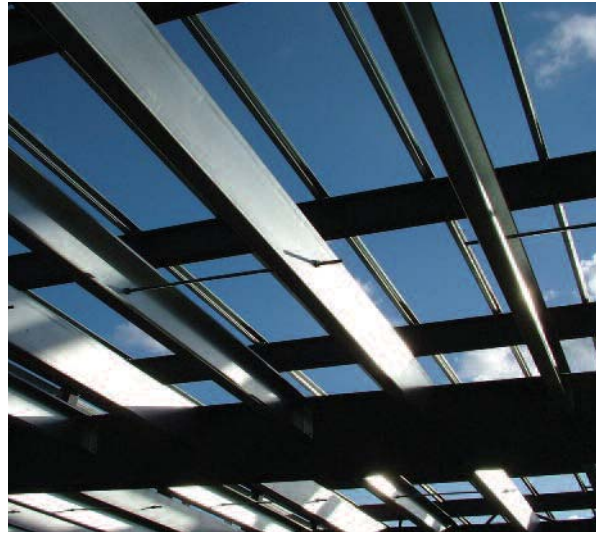

Brickwork Restraints

The Multichannel brickwork restraint has been developed to accommodate standard brick and block sizes used in construction today. The restraint provides an efficient method of restraining brickwork panels in steel framed buildings.

Compared with hotrolled alternatives it is easier to handle on site due to its light weight and no additional finishing is required.

Multichannel brickwork restraints suit 100mm and 140mm block/brickwork walls and are available in lengths up to 9m either as a single or compound section. Attachment to the brickwork can be Rawlbolts (or similar), threaded rods built into the wall or flat strapped brick restraints built into the brickwork.



General Engineering Applications

Multichannel is suitable for a wide variety of engineering applications.

These can include:

- Roof trusses
- Stairs
- Bracing
- Conveyors
- And many more

For more information call our Technical Department on 01944 712000.

Gable Posts

Compound Multichannel members can be used as an infill gable post (to facilitate a future gable extension) where a full portal frame is provided at the gable.

Compound Multichannel posts can be supplied with side rail cleats, restraint brackets and base cleats pre-assembled in the factory to minimise site work and promote rapid erection. Alternatively a kit of parts is available for full assembly on site.

Multichannel infill posts are not suitable for free standing applications (including during erection) and must be placed between self supporting main beams and the foundations for stability.

Construction Details - Multichannel

Rail Connection

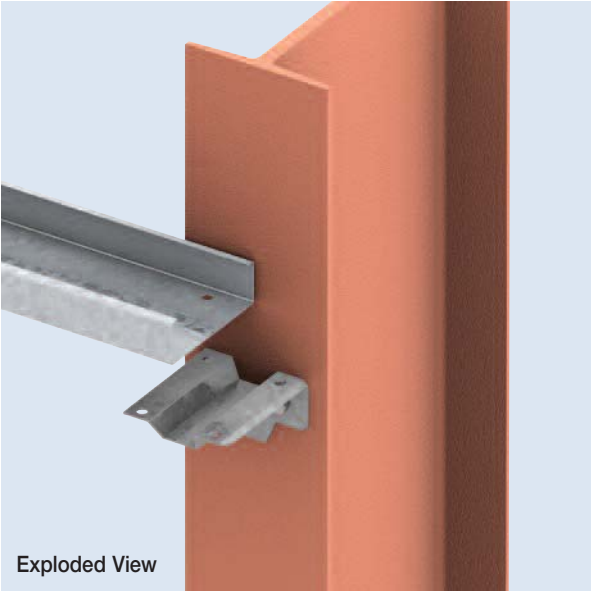

Cleat connection to Rail

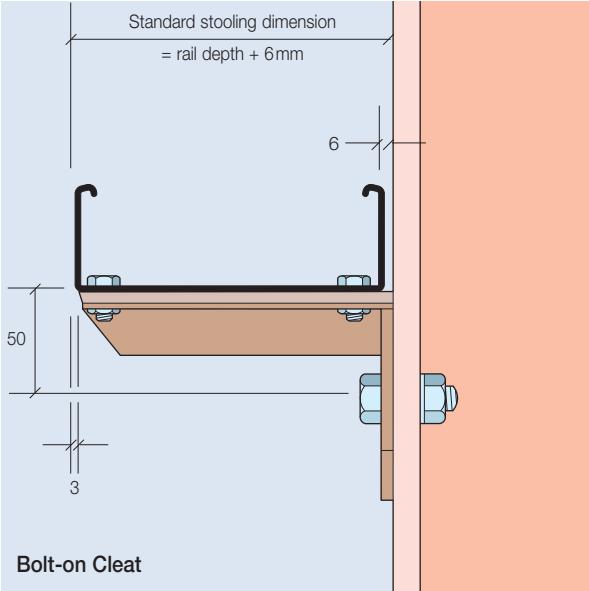

For product dimensions refer to pages 114 and 115.

Cladding Rail Sleeve

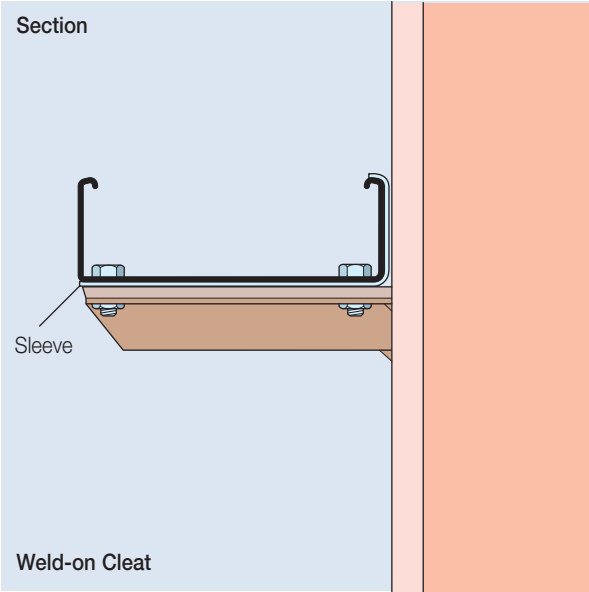
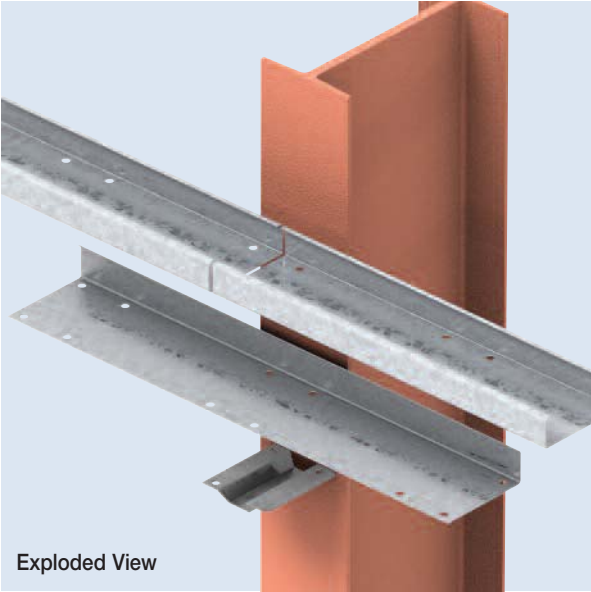

For product dimensions refer to pages 114, 115 and 118.

Cladding Rails External Corner

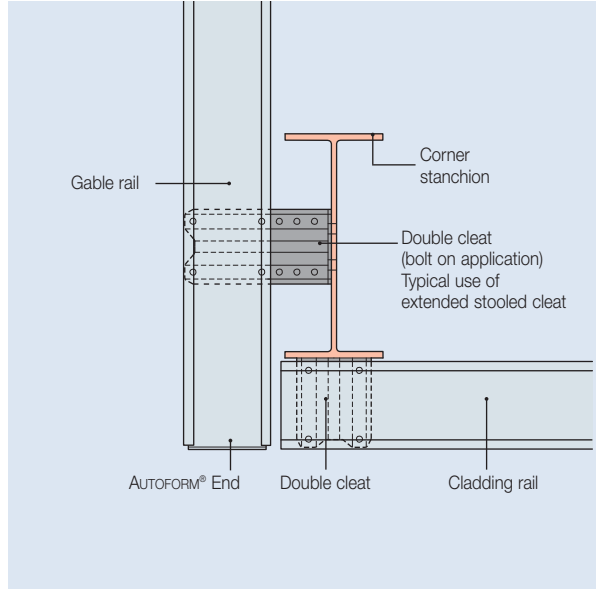
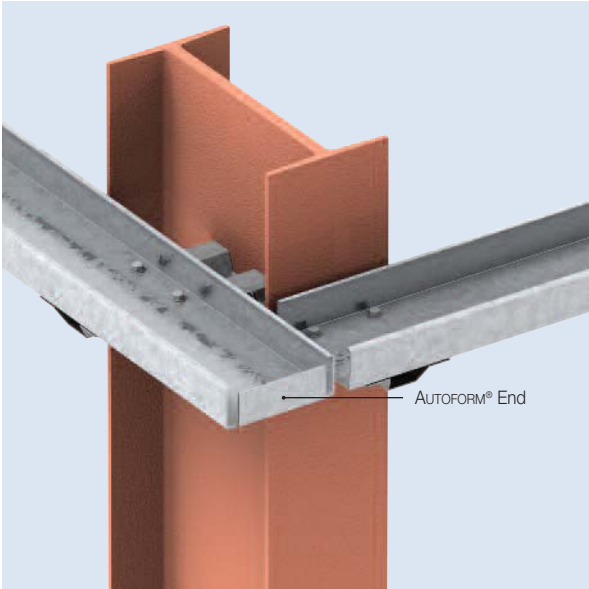

For product dimensions refer to pages 114, 115 and 118.

Cladding Rails Internal Corner

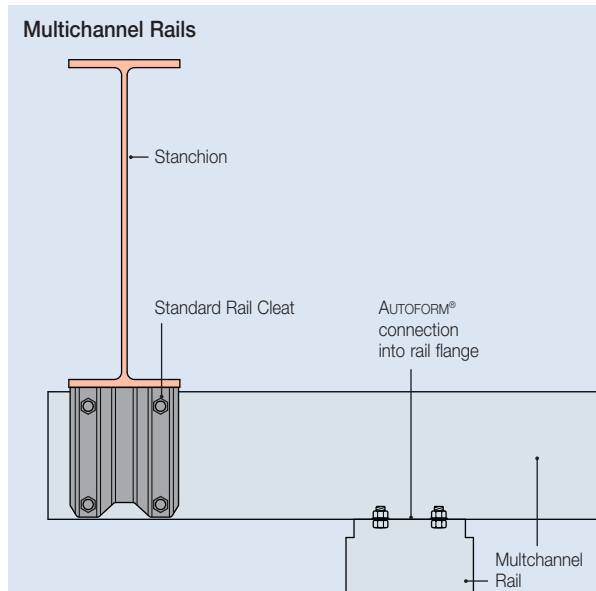
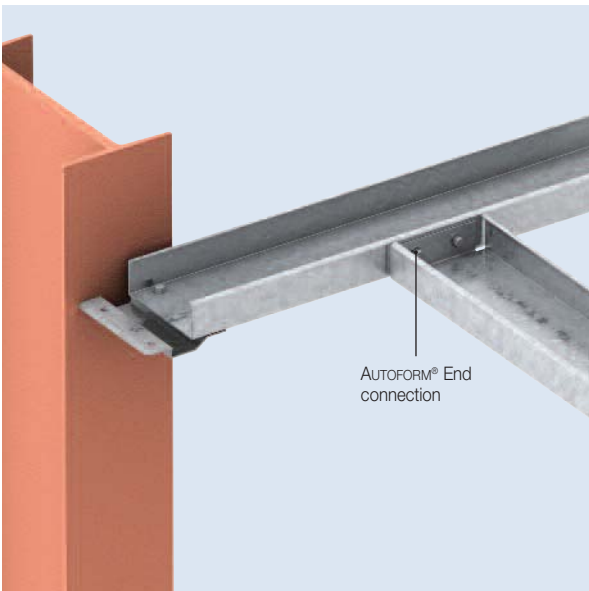

For product dimensions refer to pages 114, 115 and 118.

Multichannel

Construction Details - Multichannel

Slotted Cladding Rail on a Firewall

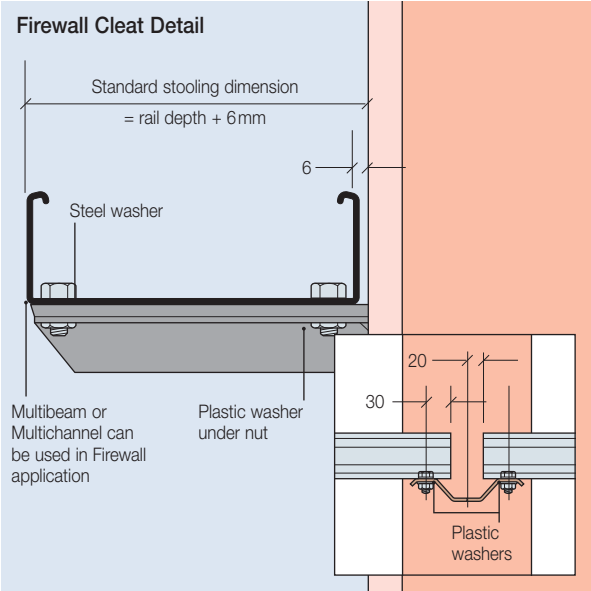
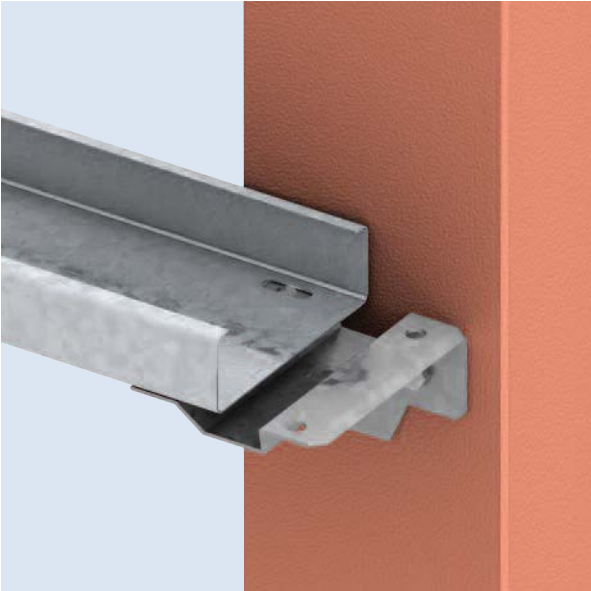

For product dimensions refer to pages 114 and 115.

Rod Diagonal with G140/150

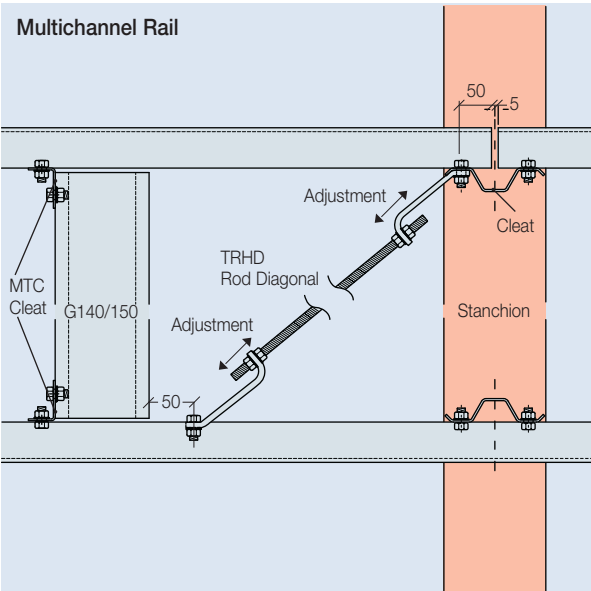

For product dimensions refer to pages 120 and 121.

Stanchion Stay Type RNA

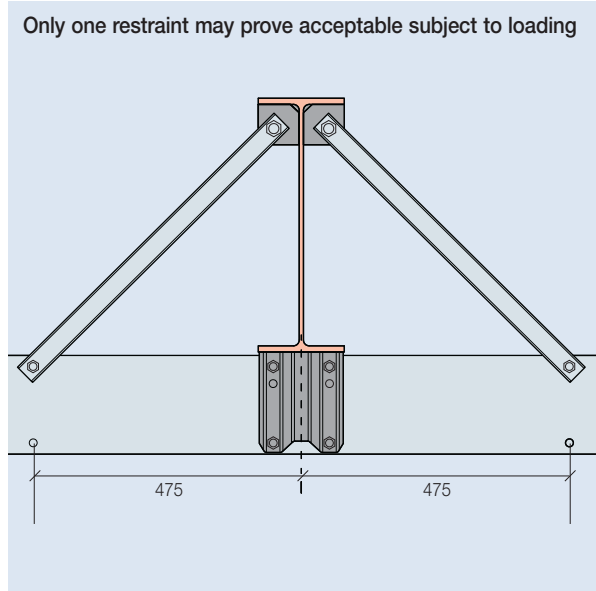
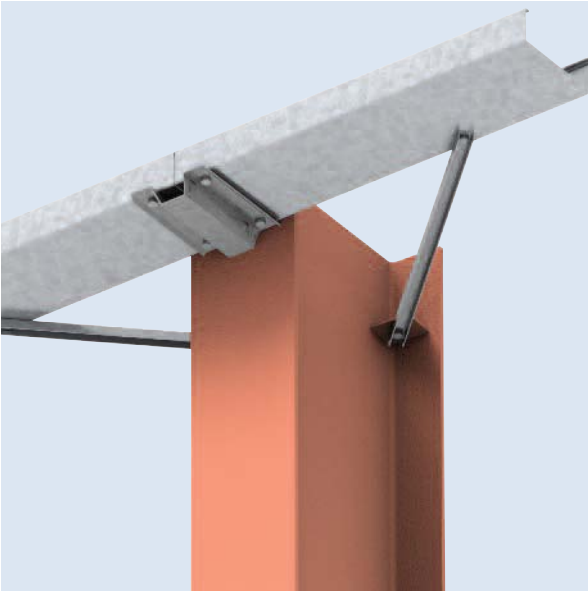

For product dimensions refer to page 120.

Stanchion Stay Type RNB

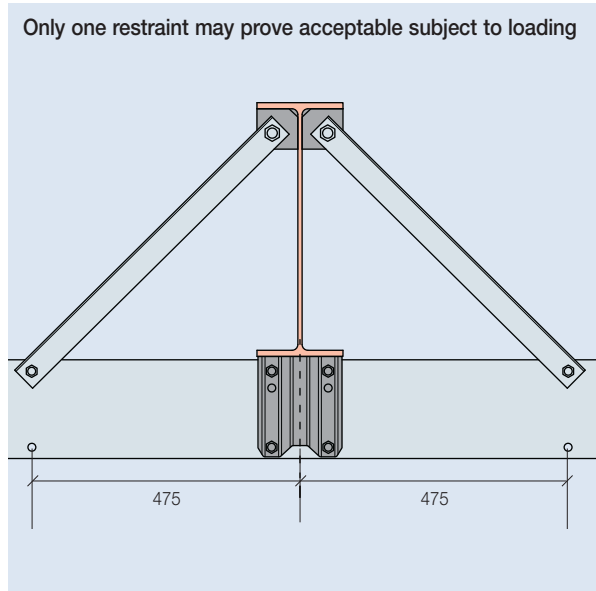
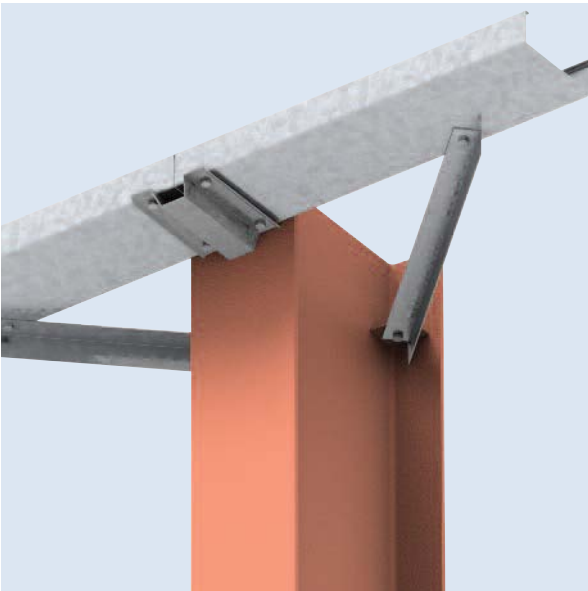

For product dimensions refer to page 120.

Multichannel

Construction Details - Multichannel

Diagonal Tie Wire Restraint

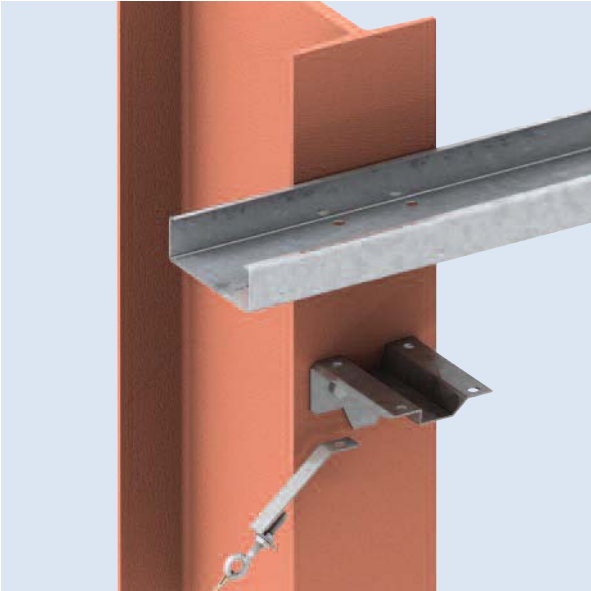

For product dimensions refer to page 120.

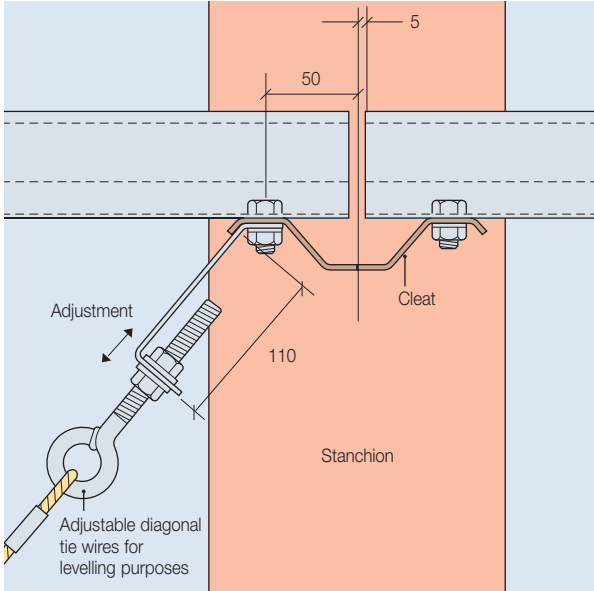

Top cleat fixes to cleat hole nearest column.

Multichannel between Columns - Autoform connection

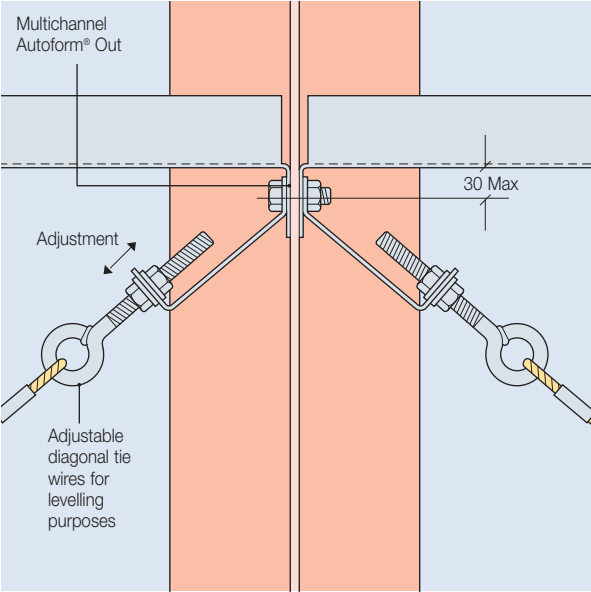

For product dimensions refer to page 120.

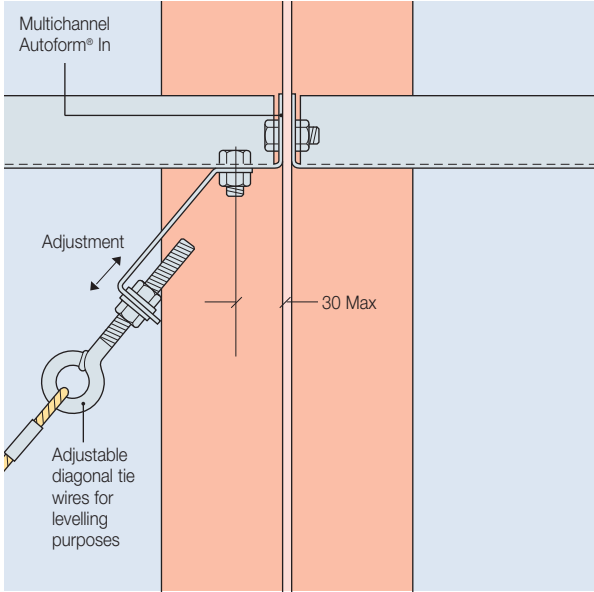

Door Openings

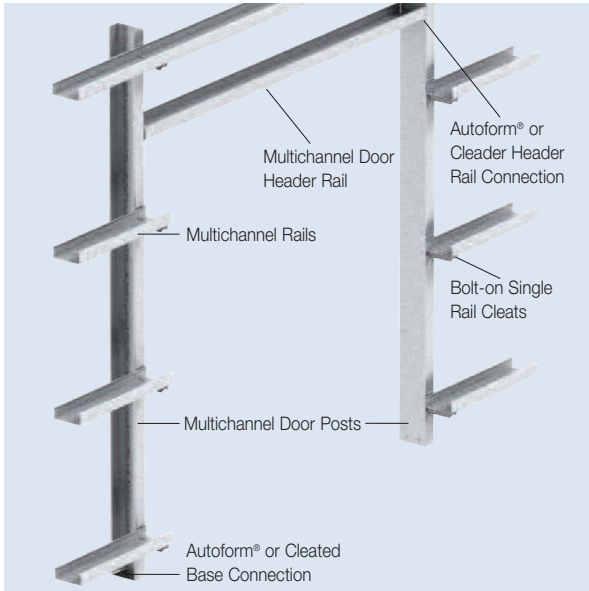

For product dimensions refer to pages 114, 115 and 118.

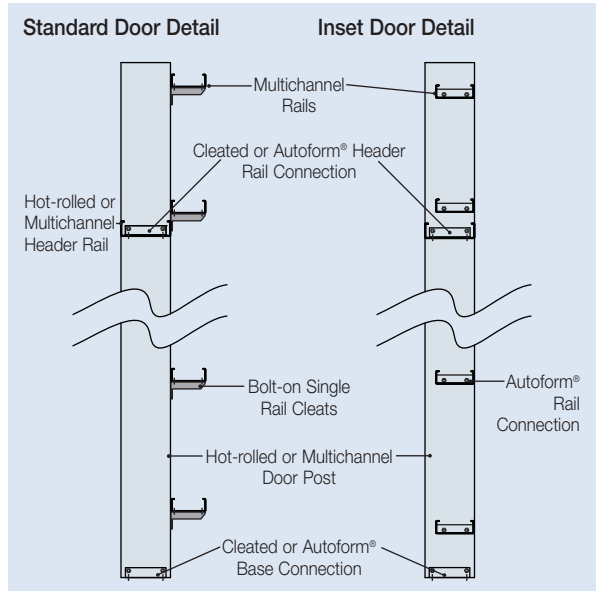

When the door framework needs to be set to the same level as the cladding rails, the Autoform® detail can be used

Window Openings

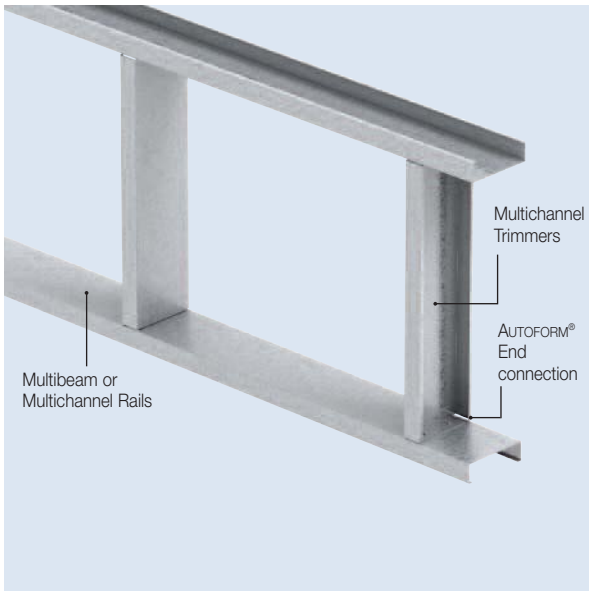

For product dimensions refer to page 118.

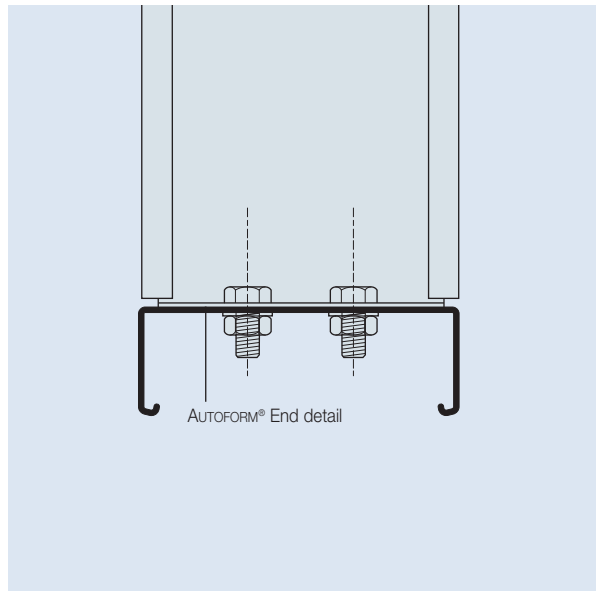

Multichannel

Construction Details - Multichannel

Column Top

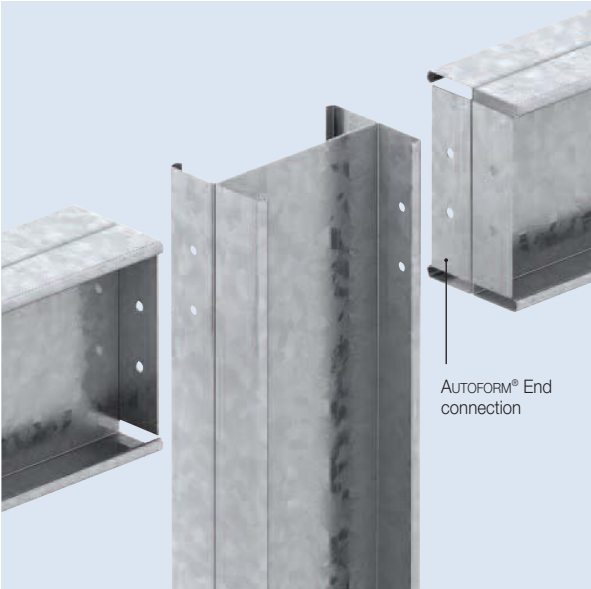

For product dimensions refer to page 118.

Column Base

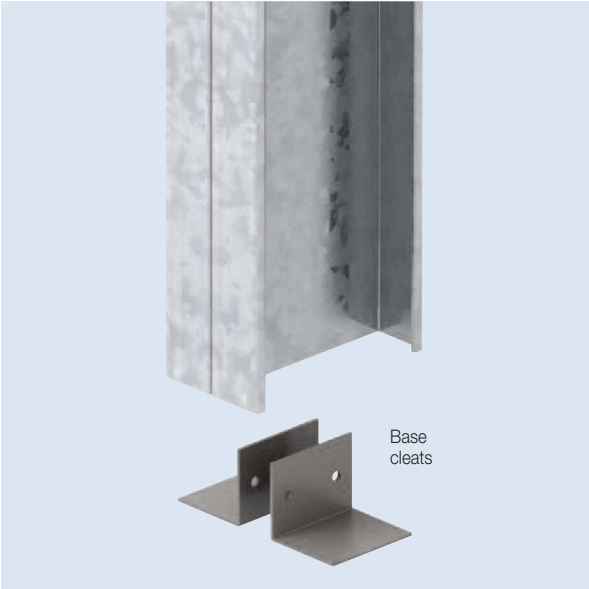

For product dimensions refer to page 121.

Gable Post



For product dimensions refer to page 120.

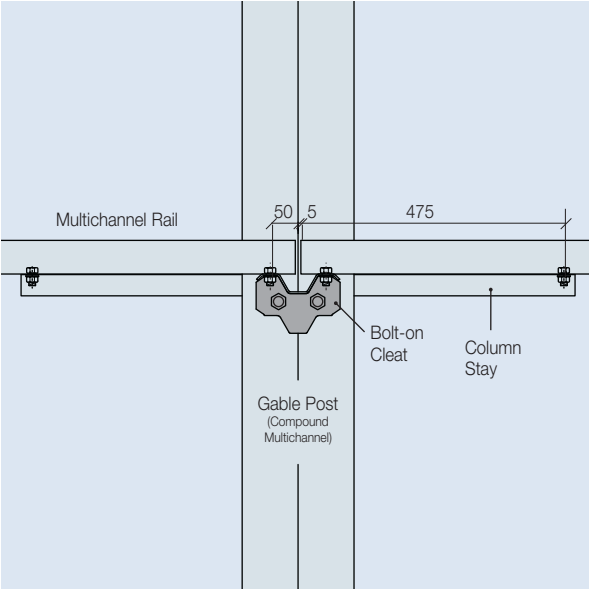

Mezzanine Floor Restraint

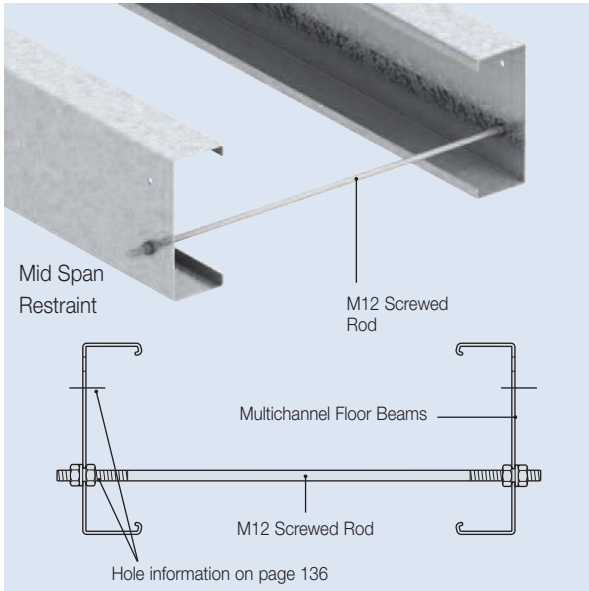

For product dimensions refer to page 119.

Heavy Duty Mezzanine Floor Restraint

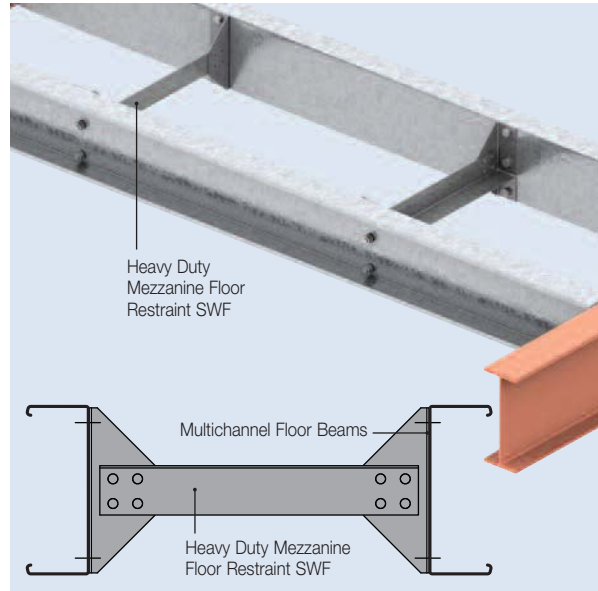

For product dimensions refer to page 119.

Mezzanine Floor between steelwork

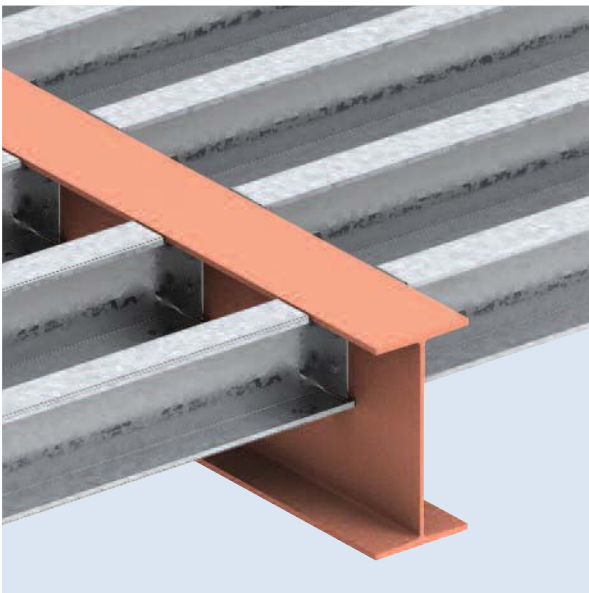

For product dimensions refer to page 118.

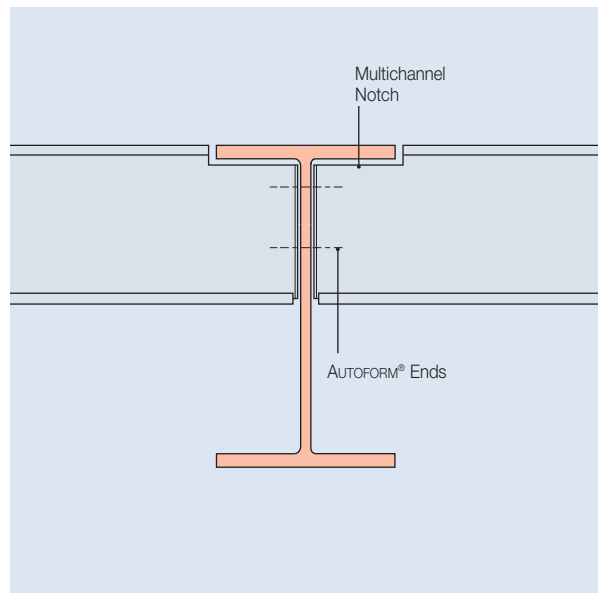

Construction Details - Multichannel

Mezzanine Floor over support steelwork with cleat

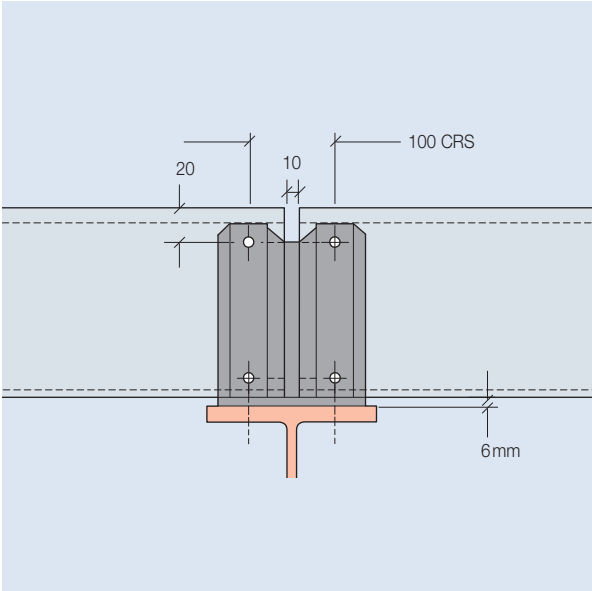
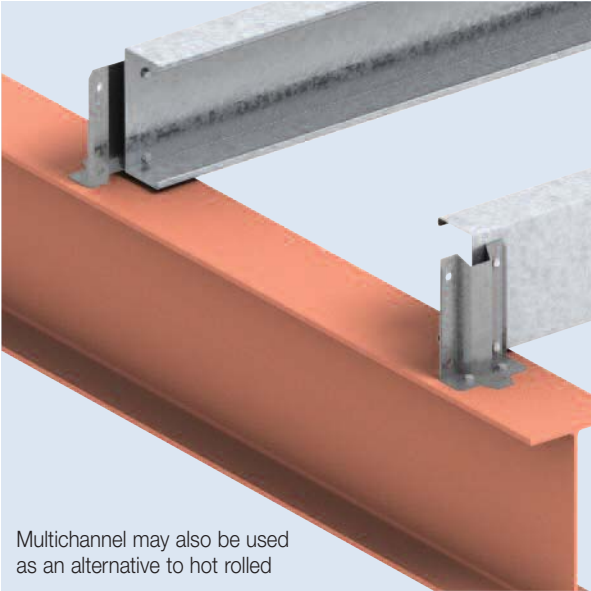

For product dimensions refer to page 115.

Mezzanine Floor over support steelwork without cleat

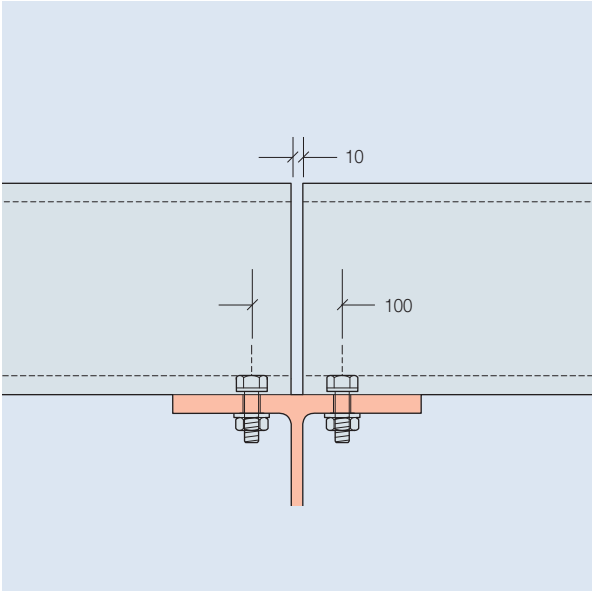
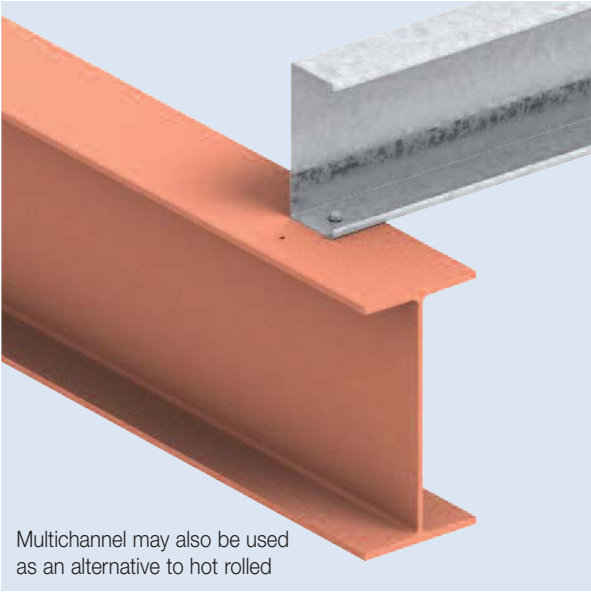

For product dimensions refer to page 114.

Case Study

The Pillar Box, Coventry

A major regeneration and refurbishment of the old Post Office creating accommodation for over 100 students at Coventry University. Kingspan Structural Products provided a complete steel frame incorporating Multibeam purlins and Multichannel rails and joists.

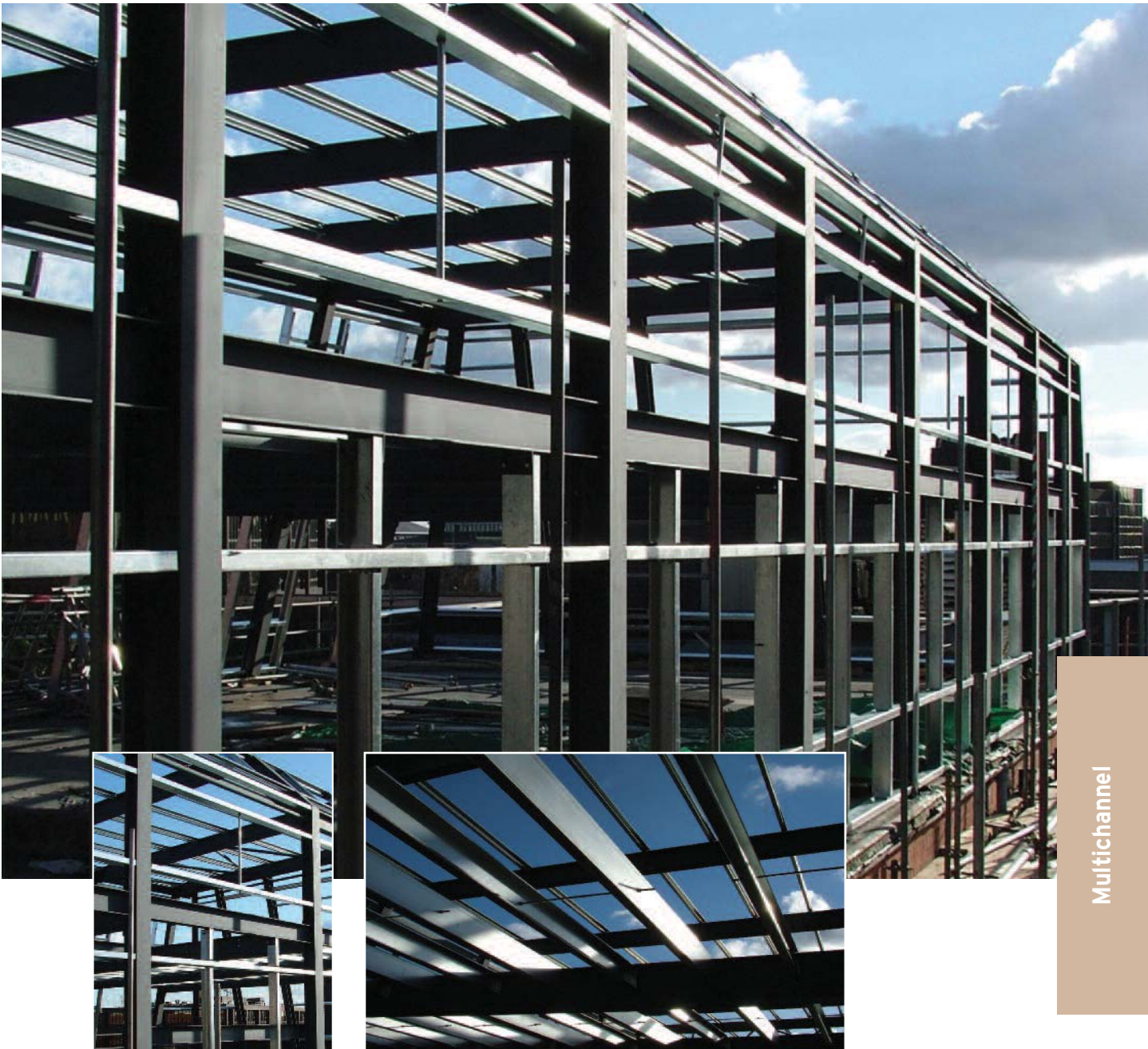

Multichannel

Product Dimensions and References

Multichannel Sections

References	Weight Kg/m	Dims (mm)		Gauge (mm)
		A	B	
L145070120	2.75	145	70	1.20
L145070130	2.99	145	70	1.30
L145070140	3.21	145	70	1.40
L145070150	3.45	145	70	1.50
L145070160	3.69	145	70	1.60
L145070180	4.15	145	70	1.80
L145070200	4.63	145	70	2.00
L145070220	5.06	145	70	2.20
L175070120	3.02	175	70	1.20
L175070130	3.29	175	70	1.30
L175070140	3.52	175	70	1.40
L175070150	3.79	175	70	1.50
L175070160	4.05	175	70	1.60
L175070180	4.55	175	70	1.80
L175070200	5.08	175	70	2.00
L175070220	5.56	175	70	2.20
L175070250	6.35	175	70	2.50
L205070120	3.29	205	70	1.20
L205070130	3.58	205	70	1.30
L205070140	3.84	205	70	1.40
L205070150	4.13	205	70	1.50
L205070160	4.41	205	70	1.60
L205070170	4.67	205	70	1.70
L205070180	4.96	205	70	1.80
L205070200	5.53	205	70	2.00
L205070220	6.05	205	70	2.20
L205070250	6.91	205	70	2.50
L205070270	7.49	205	70	2.70

References	Weight Kg/m	Dims (mm)		Gauge (mm)
		A	B	
L235070130	3.86	235	70	1.30
L235070140	4.14	235	70	1.40
L235070150	4.45	235	70	1.50
L235070160	4.76	235	70	1.60
L235070170	5.04	235	70	1.70
L235070180	5.35	235	70	1.80
L235070200	5.97	235	70	2.00
L235070220	6.53	235	70	2.20
L235070250	7.46	235	70	2.50
L235070270	8.08	235	70	2.70
L265070140	4.46	265	70	1.40
L265070150	4.79	265	70	1.50
L265070160	5.13	265	70	1.60
L265070180	5.76	265	70	1.80
L265070200	6.43	265	70	2.00
L265070220	7.03	265	70	2.20
L265070250	8.03	265	70	2.50
L265070270	8.70	265	70	2.70
L300090150	5.64	300	90	1.50
L300090160	6.03	300	90	1.60
L300090180	6.78	300	90	1.80
L300090200	7.56	300	90	2.00
L300090250	9.44	300	90	2.50
L300090270	10.23	300	90	2.70
L350090150	6.20	350	90	1.50
L350090160	6.63	350	90	1.60
L350090180	7.45	350	90	1.80
L350090200	8.32	350	90	2.00
L350090250	10.39	350	90	2.50
L350090270	11.25	350	90	2.70

Reference Key

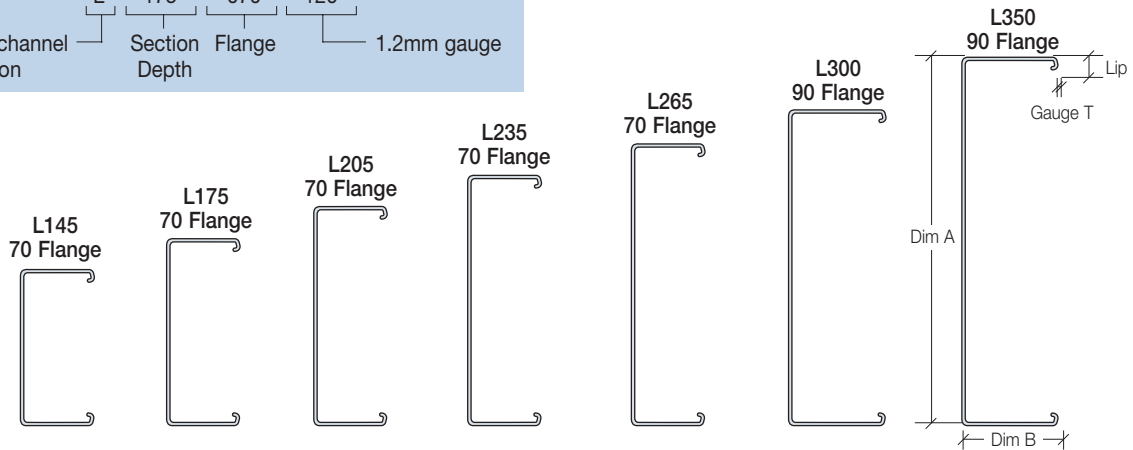
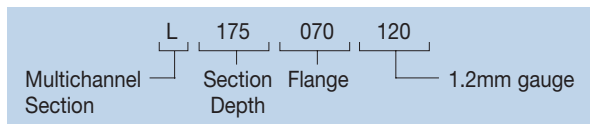

L145 Gauges	L175 Gauges	L205 Gauges	L235 Gauges	L265 Gauges	L300 Gauges	L350 Gauges
1.2	1.2	1.2	-	-	-	-
1.3	1.3	1.3	1.3	-	-	-
1.4	1.4	1.4	1.4	1.4	-	-
1.5	1.5	1.5	1.5	1.5	1.5	1.5
1.6	1.6	1.6	1.6	1.6	1.6	1.6
-	-	1.7	1.7	-	-	-
1.8	1.8	1.8	1.8	1.8	1.8	1.8
2.0	2.0	2.0	2.0	2.0	2.0	2.0
2.2	2.2	2.2	2.2	2.2	-	-
-	2.5	2.5	2.5	2.5	2.5	2.5
-	-	2.7	2.7	2.7	2.7	2.7

Multicleats

Table 4:1 Multicleat References

Sheeting Line (mm)	Multichannel Section Depths (mm)	Cleat Type			
		Weld-On		Bolt-On	
		Double	Single	Double	Single
-	G140/150	-	MS 120x	-	MS 120Bx
151	145	MD 145	MS 145	MD 145BB	MS 145BB
181	up to 175	MD 175	MS 175	MD 175BB	MS 175BB
211	up to 205	MD 205	MS 205	MD 205BB	MS 205BB
241	up to 235	MD 235	MS 235	MD 235BB	MS 235BB
271	up to 265	MD 265	MS 265	MD 265BB	MS 265BB
306	300	MD 300	MS 300	MD 300BB	MS 300BB
356	350	MD 350	MS 350	MD 350BB	MS 350BB

*All Cleats are supplied in unpainted steel as standard. Painted or galvanised finishes are available if required. Please note, for galvanised finish there is an extended lead time, please contact our Sales Department for more information.

Table 4:2 Multicleat Options

Options	Suffix	Example
Bolt-on Black	BB	MD175BB
Bolt-on Painted	BE	MD175BE
Bolt-on Galvanised	BG	MD175BG
Stiffened	S	MD265BS
Extended	X	MD265X300 (ie; 300mm from rafter face)

300/350 deep are supplied stiffened, see page 117 for details.

All multicleat holes shown are 14mm diameter.

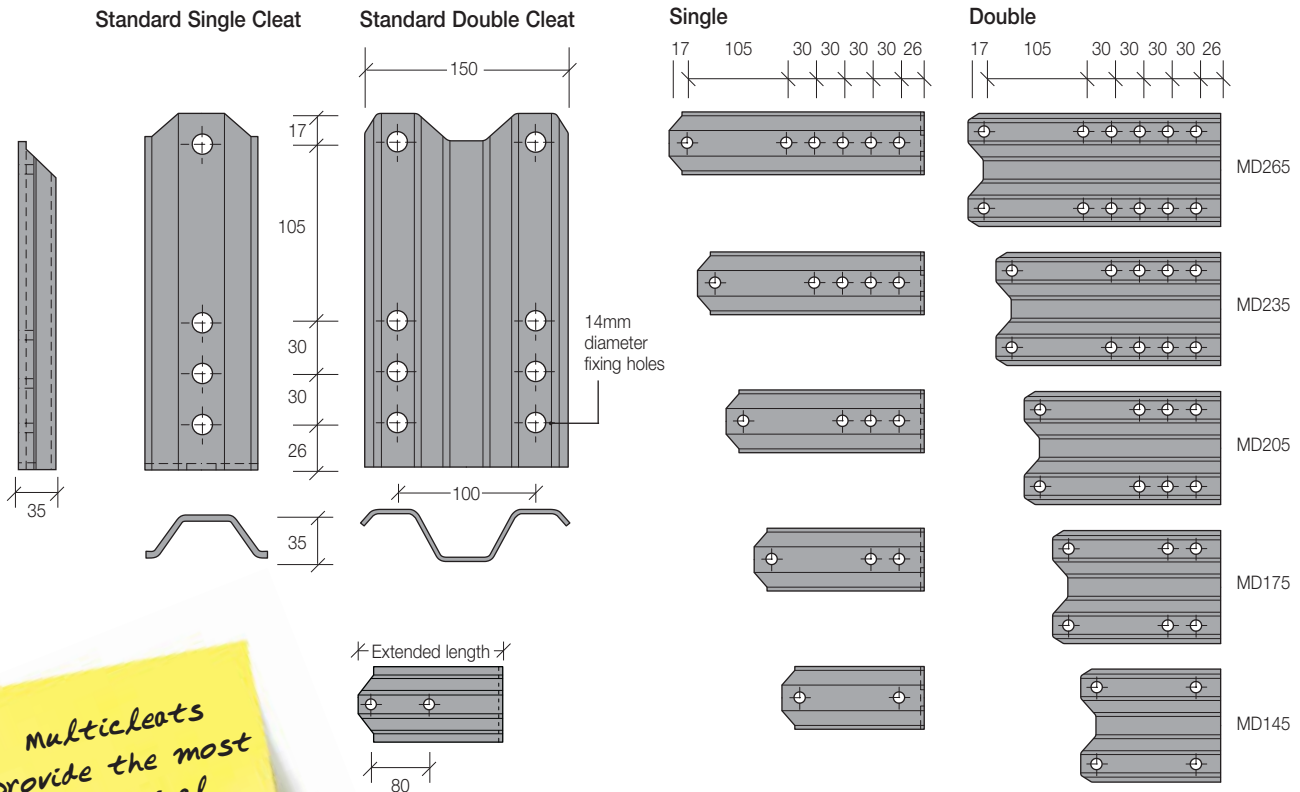

Multicleats provide the most economical solution for stooled off rails.

Multichannel

Product Dimensions and References

Bolt-on Rail Cleats

All Multicleats are available as bolt-on.
See table 4:2 on page 115.

Table 4:3 Base plate thicknesses

Multicleat Depth	Cleat Base Plate Thickness (mm)
G140/150	6
145	6
175	6
205	8
235	8
265	8
300	8
350	8

Table 4:4 Base plate holes cross centres

Base Plate Holes Cross Centres*	Dim H (mm)
50	55
60	55
70 (standard)	50
80	50
90	50
100	50

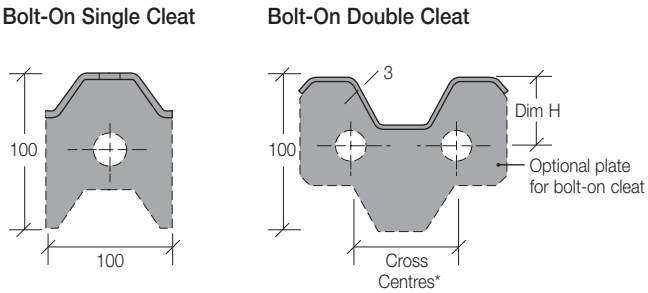
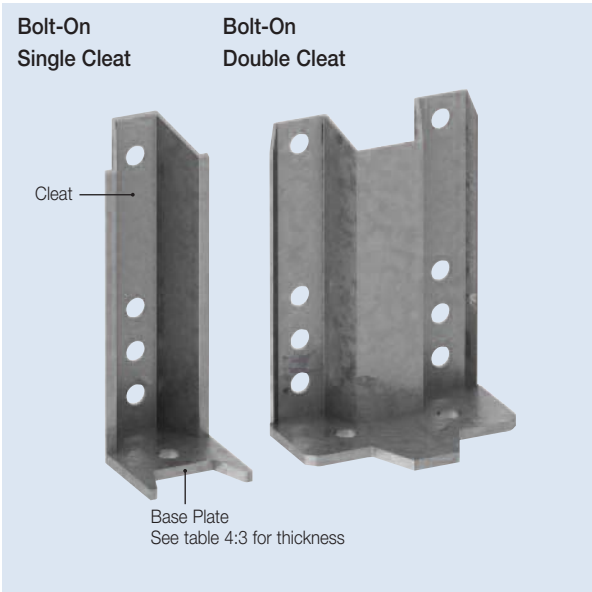

Multicleats allow differing section sizes to be used on any elevation, while maintaining a constant sheeting line.





Stiffened Rail Multicleats

All Multicleats are available with stiffeners where required, eg. tiled roof applications. Add 'stiffened' to Multicleat reference when ordering. See table 4:2.

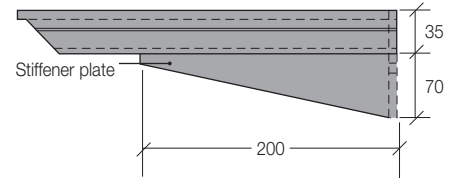

Multicleat Arrangement

Multicleats allow differing section sizes to be used on any elevation, while maintaining a constant sheeting line.

Diagram A

shows a 265 section fixed to a 265 cleat.

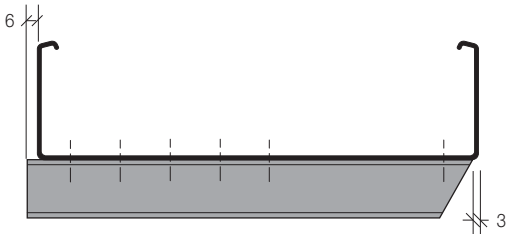
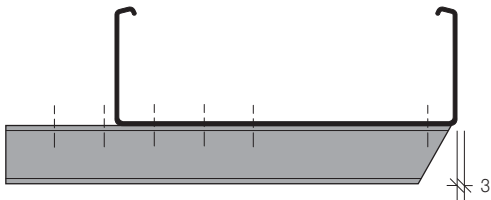

Diagram B

shows a 205 section fixed to a 265 cleat.



Extended Rail Cleats

Extended cleats can be manufactured to meet your specific requirements. These are manufactured to order and will be at an additional cost.

NB: Add 'extended' to cleat reference when ordering.

Extended **double** cleats over 270mm long are supplied complete with stiffeners. **These are not available with single cleats.**

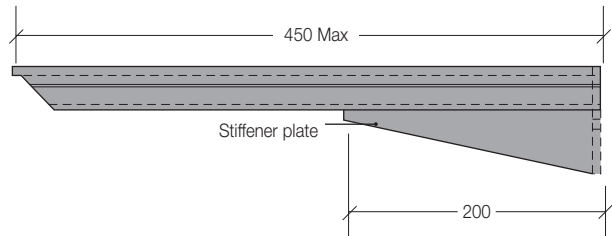

Product Dimensions and References

Multichannel Sleeves

Used to provide continuity at a rail joint normally at a single span to a double, or a single to a single span or at all joints in heavy end bay layout.

Please specify sleeve reference as below.
For construction details see page 104.

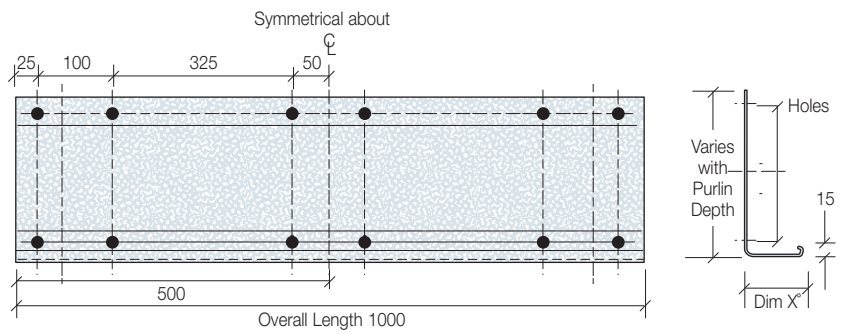

Table 4:5 Multichannel Sleeve References

Sleeve Reference	To suit channel section	
	Web	Flange
CSL14570	145	70
CSL17570	175	70
CSL20570	205	70
CSL23570	235	70
CSL26570	265	70
CSL30090	300	90
CSL35090	350	90

* Dim X is: 80 when 70 flange
100 when 90 flange

All holes are 14mm Dia unless noted.

Autoform® in and Autoform® Out

Standard Autoform® Ends are supplied with a 50mm return on all section sizes, non-standard returns are available on request.
Dim A holes should be 20mm from the web for 14mm dia holes (M12 bolts) or 25mm from the web for 18mm (M16 bolts).

Part Reference
AFIN
AFOUT

For construction details see pages 105 and 108.
Minimum channel length = 125mm
For Autoform details please see page 136.

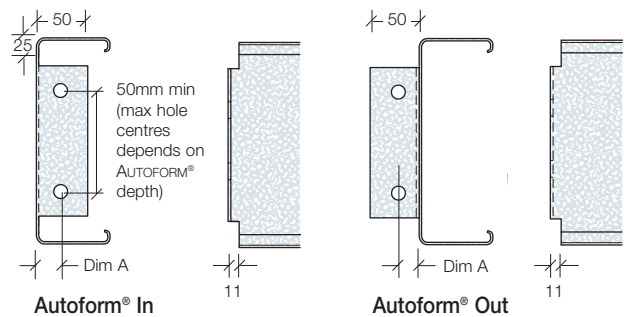

Notches

Notches can be cut from the top, bottom or both ends. Standard notches are 25mm in depth cut to the lengths shown. Non-standard notches can be cut subject to quantity, please contact our Technical Department for details.

Notch Reference

	Section	Min. (mm)	Max. (mm)
Notch Length	All	30	250
	145	11	48
	175	11	61
Notch Depth	205	11	76
	235	11	*
	265	11	*
	300	11	*
	350	11	*

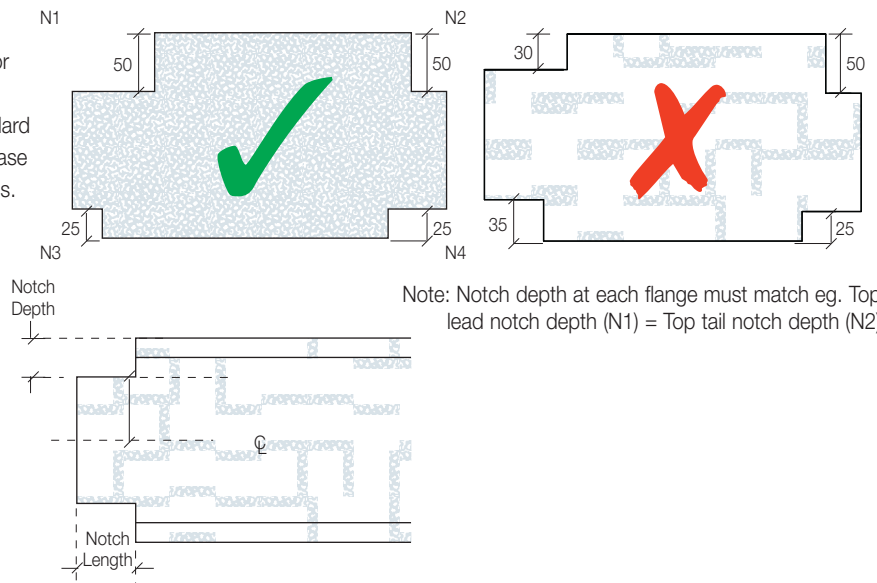

*For maximum notch depth please contact our Customer Service Department
For construction details see pages 109, 110 and 111.

Tube Strut TSA

Used to restrain purlins and side rails

Part Reference

TSA0000

where 0000 = Rail Centres

eg; TSA1000 (Rail Centres = 1000mm)

Minimum length = 150mm

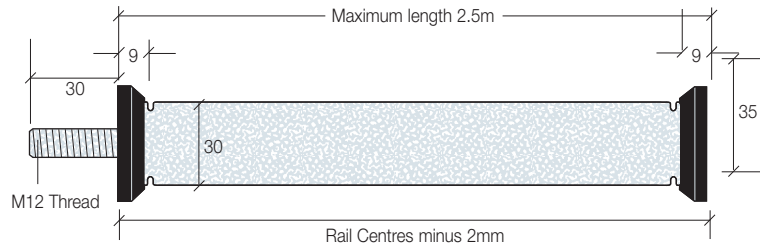

For design details see page 98. For construction details see page 76.

Tube Strut TSB

This tube strut is used to restrain side rails where a flush face is required

Part Reference

TSB0000

where 0000 = Rail Centres

eg; TSB1000 (Rail Centres = 1000mm)

Minimum Length = 150mm

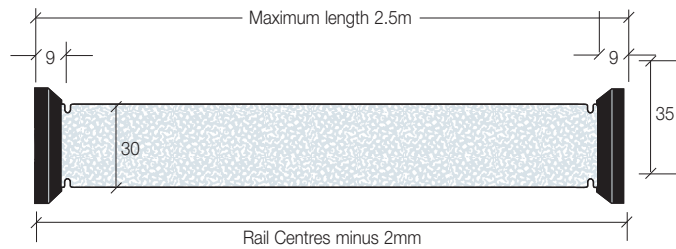

For design details see page 98. For construction details see page 76.

Heavy Duty Mezzanine Floor Restraint SWF

Angle strut used to restrain the larger sections on Mezzanine Floor applications

Part Reference

SWF0000

where 0000 = Overall length

eg; SWF1500 (Overall length = 1500mm)

Channel section size must be specified

Minimum length = 250mm

For construction details see page 111.

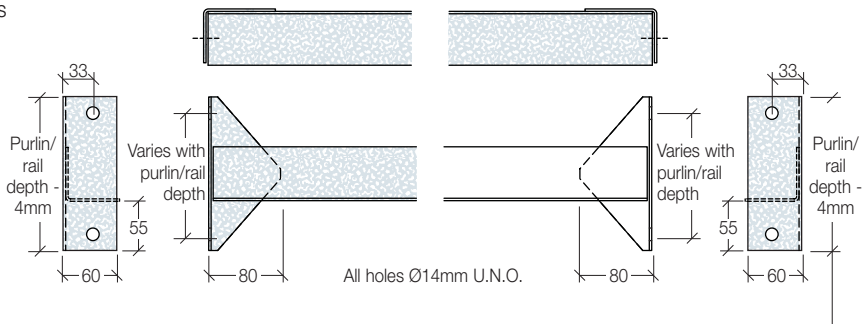

Clamp Plates

Used to fix and complete a run of tube struts

Part Reference

CA

For construction details see page 76.

40x50x3mm plate

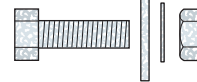

CA

Screwed Rod

Restraint on mezzanine floor beams

Part Reference

TR0000

where 0000 = Dim A

eg TR0000 (Purlin Centres = 500mm)

For construction details see page 111.

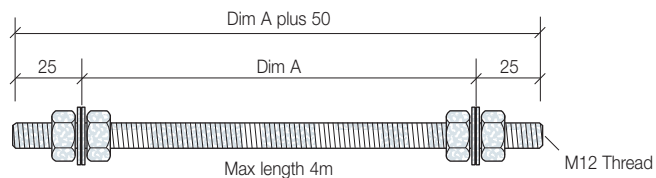

Product Dimensions and References

Rafter and Stanchion Restraint RNA

Channel stay to provide compression and tension restraint from the purlin or rail to the inner flange of the main frame

Part Reference

RNA0000

where 0000 = Length between Hole Centres

eg; RNA1000 (Hole Centres = 1000mm)

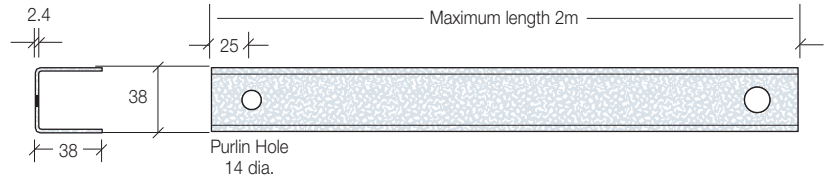

For construction details see page 107.

Rafter and Stanchion Restraint RNB

Angle stay to provide compression and tension restraint from the purlin or rail to the inner flange of the main frame suitable for smaller main frame sections

Part Reference

RNB0000

where 0000 = Length between Hole Centres

eg; RNB1000 (Hole Centres = 1000mm)

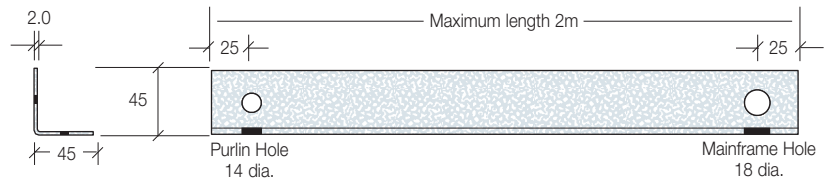

For construction details see page 107.

Diagonal Tie Wire

Used on some long purlin slopes to support the self weight of the cladding and transfer it to the rafters

Part Reference

DB

DA

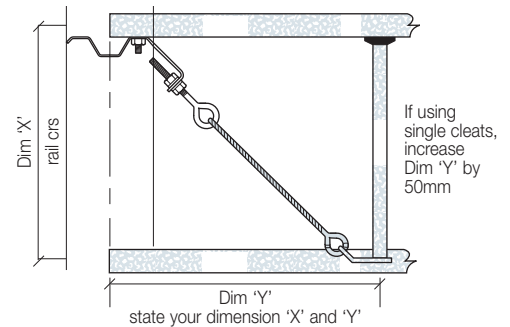
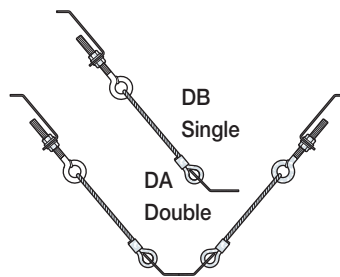

Please state your dimension 'X' and 'Y'

For design details see pages 98, 99 and 100. For construction details see page 108.

Multichannel Base Cleats

Section	Cleat Reference	Length
L175	MC175	155mm
L205	MC205	185mm
L235	MC235	215mm
L265	MC265	245mm
L300	MC300	280mm
L350	MC350	330mm

Hot Rolled end cleats are also available. Please contact Kingspan sales for more information.

All holes are 18mm Dia.

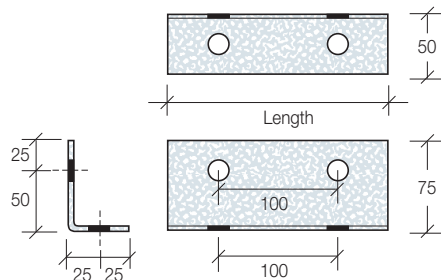

MTC Cleats

Angle cleat to attach Multibeam or Multichannel together

Part Reference Rail Depth

MTC145	145mm
MTC175	175mm
MTC205	205mm
MTC235	235mm
MTC265	265mm
MTC300	300mm
MTC350	350mm

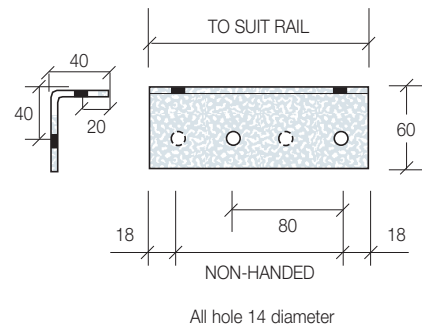

For construction details see pages 100, 101 and 106.

Note: These cleats are supplied with opposite hand holes.

Rod Diagonal

The diagonal used with the rails when supporting horizontal cladding system when panel joints are within the span to transfer loads to the main frame

Part Reference

TRHD0000

where 0000 = length between hole centres

eg; TRHD1000 (Hole Centres = 1000mm)

For construction details see pages 101 and 106.

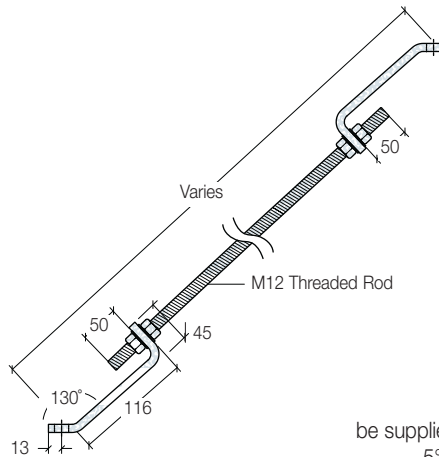

Diagonal angle must be supplied when ordering (Available in 5° increments from 30° to 60°).

Horizontal Panel Vertical Support

Used as the vertical support between Multichannel horizontal rails to support horizontally laid Insulated panels

Part Reference

G140/150

Maximum length = 8 metres

1.5mm galvanised steel.

For use within the span it can be provided complete with end connections attached.

For construction details see pages 100, 101 and 106.

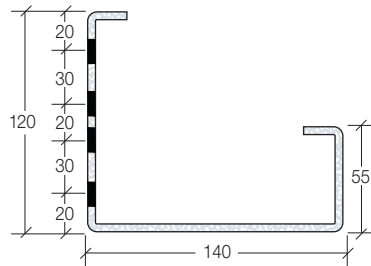

All holes 14mm diameter
Standard hole grouping are at backmarks of 20mm, 50mm, 70mm and 100mm.
Hole placement along the length to be specified by the customer.

Multibracket

Multibrackets are used to make connections between Multichannels and Multibeam

Part Reference

MB1A (Left hand) as shown

MB1B (Right hand)

Material 3.0mm galvanised steel.

All holes 14 diameter.

For construction details see pages 100, 101 and 106.

Note: Multibrackets are not suitable for connecting sections to a 90mm flange.

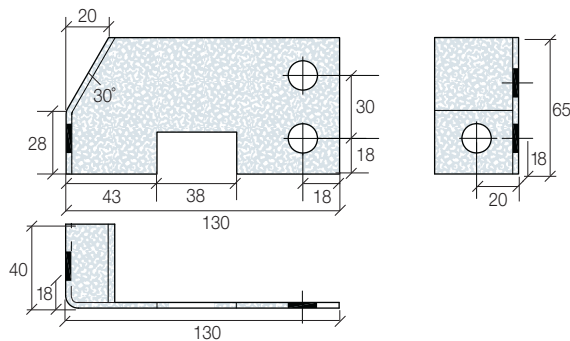

Rail Stubs

Part Reference

SM0000

where 0000 = required length 'Dim L'

Manufactured from 2.7mm galvanised steel strip.

All holes 14 diameter.

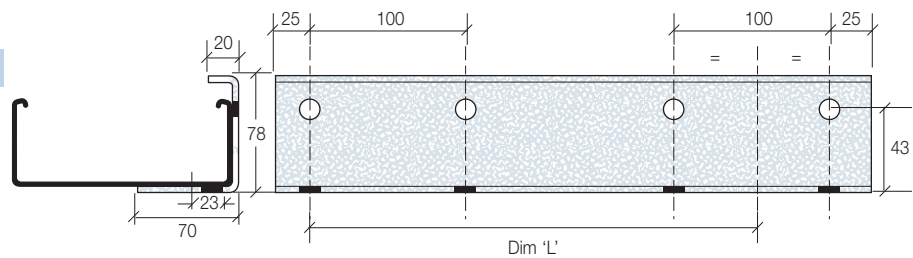

Multichannel - Section Properties

Table 4:6 Multichannel section properties

Section	D mm	Fl mm	t mm	Area cm ²	Wt kg/m	Ixx cm ⁴	Gross Zxx cm ³	Iyy cm ⁴	Zyy cm ³	Rxx cm	Ryy cm	Q	2Iyy cm ⁴
L145070120	145	70	1.20	3.68	2.75	125.52	17.32	26.07	4.64	5.86	2.67	0.55	80.30
L145070130	145	70	1.30	3.99	2.99	135.84	18.74	28.12	5.06	5.85	2.66	0.58	86.82
L145070140	145	70	1.40	4.30	3.21	146.07	20.15	30.14	5.47	5.85	2.66	0.61	93.27
L145070150	145	70	1.50	4.60	3.45	156.23	21.56	32.14	5.88	5.85	2.65	0.64	99.67
L145070160	145	70	1.60	4.91	3.69	166.30	22.94	34.09	6.29	5.84	2.64	0.67	105.99
L145070180	145	70	1.80	5.51	4.15	186.23	25.69	37.93	7.11	5.83	2.63	0.72	118.47
L145070200	145	70	2.00	6.11	4.63	205.84	28.40	41.65	7.91	5.82	2.62	0.75	130.69
L145070220	145	70	2.20	6.71	5.06	225.36	31.09	45.34	8.72	5.82	2.61	0.78	142.67
L175070120	175	70	1.20	4.03	3.02	193.51	22.12	27.79	4.65	6.95	2.63	0.51	80.30
L175070130	175	70	1.30	4.37	3.29	209.48	23.95	29.98	5.07	6.95	2.63	0.53	86.82
L175070140	175	70	1.40	4.71	3.52	225.31	25.76	32.13	5.48	6.94	2.62	0.56	93.28
L175070150	175	70	1.50	5.04	3.79	241.06	27.56	34.26	5.89	6.94	2.62	0.59	99.67
L175070160	175	70	1.60	5.38	4.05	256.66	29.34	36.34	6.30	6.93	2.61	0.61	106.00
L175070180	175	70	1.80	6.04	4.55	287.59	32.87	40.44	7.12	6.92	2.60	0.65	118.47
L175070200	175	70	2.00	6.70	5.08	318.05	36.36	44.40	7.92	6.91	2.58	0.69	130.69
L175070220	175	70	2.20	7.36	5.56	348.06	39.79	48.24	8.71	6.90	2.57	0.72	142.67
L175070250	175	70	2.50	8.33	6.35	392.24	44.84	53.77	9.87	6.89	2.55	0.75	160.19
L205070120	205	70	1.20	4.38	3.29	279.52	27.28	29.24	5.68	8.01	2.59	0.47	80.30
L205070130	205	70	1.30	4.75	3.58	302.65	29.53	31.54	5.08	8.01	2.59	0.49	86.82
L205070140	205	70	1.40	5.11	3.84	325.60	31.77	33.80	5.49	8.00	2.58	0.52	93.28
L205070150	205	70	1.50	5.48	4.13	348.43	34.00	36.04	5.91	8.00	2.57	0.54	99.67
L205070160	205	70	1.60	5.84	4.41	371.06	36.21	38.23	6.31	7.99	2.57	0.56	106.00
L205070170	205	70	1.70	6.21	4.67	393.58	38.41	40.40	6.72	7.99	2.56	0.58	112.27
L205070180	205	70	1.80	6.57	4.96	415.95	40.59	42.53	7.13	7.98	2.55	0.60	118.47
L205070200	205	70	2.00	7.29	5.53	460.21	44.91	46.70	7.93	7.97	2.54	0.63	130.70
L205070220	205	70	2.20	8.00	6.05	503.86	49.17	50.74	8.72	7.96	2.53	0.66	142.68
L205070250	205	70	2.50	9.06	6.91	568.20	55.45	56.55	9.88	7.94	2.51	0.69	160.20
L205070270	205	70	2.70	9.76	7.49	610.33	59.56	60.26	10.63	7.93	2.49	0.71	171.58
L235070130	235	70	1.30	5.12	3.86	417.05	35.50	32.87	5.09	9.05	2.54	0.46	86.82
L235070140	235	70	1.40	5.52	4.14	448.77	38.20	35.22	5.51	9.04	2.53	0.48	93.28
L235070150	235	70	1.50	5.92	4.45	480.31	40.88	37.55	5.92	9.03	2.53	0.50	99.67
L235070160	235	70	1.60	6.31	4.76	511.60	43.55	39.83	6.33	9.03	2.52	0.52	106.00
L235070170	235	70	1.70	6.70	5.04	542.75	46.20	42.09	6.73	9.02	2.51	0.54	112.27
L235070180	235	70	1.80	7.10	5.35	573.70	48.83	44.32	7.14	9.02	2.51	0.56	118.47
L235070200	235	70	2.00	7.88	5.97	634.98	54.05	48.66	7.94	9.00	2.49	0.59	130.70
L235070220	235	70	2.20	8.65	6.53	695.46	59.20	52.86	8.73	8.99	2.48	0.61	142.68
L235070250	235	70	2.50	9.80	7.46	784.71	66.80	58.91	9.89	8.97	2.46	0.64	160.20
L235070270	235	70	2.70	10.56	8.08	843.21	71.77	62.77	10.64	8.96	2.44	0.65	171.59
L265070140	265	70	1.40	5.93	4.46	596.64	45.04	36.45	5.52	10.06	2.49	0.45	93.28
L265070150	265	70	1.50	6.36	4.79	638.68	48.21	38.86	5.93	10.05	2.48	0.47	99.67
L265070160	265	70	1.60	6.78	5.13	680.39	51.36	41.22	6.34	10.04	2.47	0.49	106.00
L265070180	265	70	1.80	7.63	5.76	763.22	57.61	45.86	7.15	10.03	2.46	0.52	118.48
L265070200	265	70	2.00	8.47	6.43	845.00	63.78	50.34	7.95	10.02	2.44	0.55	130.70
L265070220	265	70	2.20	9.30	7.03	925.77	69.88	54.68	8.74	10.00	2.43	0.57	142.69
L265070250	265	70	2.50	10.54	8.03	1045.09	78.89	60.94	9.90	9.98	2.41	0.60	160.21
L265070270	265	70	2.70	11.36	8.70	1123.36	84.79	64.93	11.97	9.97	2.40	0.61	171.60
L300090150	300	90	1.50	7.42	5.64	989.64	65.98	74.10	8.66	11.55	3.16	0.40	196.56
L300090160	300	90	1.60	7.92	6.03	1054.74	70.33	78.69	9.26	11.54	3.15	0.42	209.22
L300090180	300	90	1.80	8.91	6.78	1184.14	78.95	87.76	10.48	11.53	3.14	0.46	234.22
L300090200	300	90	2.00	9.89	7.56	1312.17	87.49	96.58	11.68	11.52	3.12	0.50	258.83
L300090250	300	90	2.50	12.33	9.44	1626.46	108.45	117.65	14.63	11.48	3.09	0.57	318.59
L300090270	300	90	2.70	13.30	10.23	1749.84	116.67	125.68	15.78	11.47	3.07	0.59	341.80
L350090150	350	90	1.50	8.15	6.20	1425.79	81.48	77.26	8.68	13.23	3.08	0.37	196.56
L350090160	350	90	1.60	8.70	6.63	1519.82	86.86	82.05	9.29	13.22	3.07	0.39	209.22
L350090180	350	90	1.80	9.79	7.45	1706.85	97.55	91.50	10.51	13.21	3.06	0.42	234.23
L350090200	350	90	2.00	10.87	8.32	1892.02	108.13	100.69	11.71	13.19	3.04	0.45	258.83
L350090250	350	90	2.50	13.56	10.39	2347.16	134.14	122.63	14.66	13.16	3.01	0.52	318.60
L350090270	350	90	2.70	14.63	11.25	2526.07	144.36	130.99	15.81	13.14	2.99	0.54	341.82

Horizontal panel vertical support member properties

Section	Thickness mm	Area cm ²	Weight kg/m	Ixx cm ⁴	Zxx Pos cm ³	Zxx Neg cm ³	Iyy cm ⁴	Zyy cm ³	Rxx cm	Ryy cm
G140/150	1.50	5.10	4.00	78.08	22.67	9.13	164.43	28.81	3.91	5.63



Multichannel - Load Tables

Multichannel Brickwork Restraint

Working Loads

Loads shown are working loads limited to a deflection of span/360 or span/500. Sections can be used as combined sheeting rail/brick restraint, or as a brick restraint built into the brickwork either as a single or compound section. Attachment to the brickwork can be: Rawlbolts, or other similar.

Threaded rods built into the wall.
Shop-fired fixings.
Flat strapped brick restraints.

Compound Multichannels will support twice the capacity of the single section shown. Sections shown do not preclude the use of thinner gauge if the capacity is adequate. Use of the AUTOFORM® connection can provide an efficient solution for the attachment of brick restraints to the steelwork.

Please contact our Technical Department for further details.

Table 4:7 Multichannel Brickwork Restraint Single Span

Span (m)	Section	Weight kg/m	Ultimate Uniformly Distributed Load (kN)			Working Load to Produce Deflection of		
			Pressure	Suction		span/300 kN	span/360 kN	span/500 kN
4.00	L175070120	3.02	13.60	13.60	6.50	5.42	3.90	
	L175070130	3.29	15.60	15.60	7.04	5.87	4.22	
	L175070140	3.52	17.65	17.65	7.57	6.31	4.54	
	L175070150	3.79	19.73	19.73	8.10	6.75	4.86	
	L175070160	4.05	21.81	21.81	8.62	7.19	5.17	
	L175070180	4.55	26.34	26.34	9.66	8.05	5.80	
	L175070200	5.08	29.90	29.90	10.69	8.90	6.41	
	L175070220	5.56	33.70	33.70	11.69	9.75	7.02	
	L175070250	6.35	39.12	39.12	13.18	10.98	7.91	
	L205070120	3.29	15.23	15.23	9.39	7.83	5.63	
	L205070130	3.58	18.23	18.23	10.17	8.47	6.10	
	L205070140	3.84	20.72	20.72	10.94	9.12	6.56	
	L205070150	4.13	23.24	23.24	11.71	9.76	7.02	
	L205070160	4.41	25.77	25.77	12.47	10.39	7.48	
	L205070170	4.67	28.28	28.28	13.23	11.02	7.93	
	L205070180	4.96	30.76	30.76	13.98	11.64	8.39	
	L205070200	5.53	35.59	35.59	15.46	12.89	9.28	
	4.50	L175070120	3.02	12.09	12.09	5.14	4.28	3.08
L175070130		3.29	13.86	13.86	5.56	4.63	3.34	
L175070140		3.52	15.69	15.69	5.98	4.99	3.59	
L175070150		3.79	17.54	17.54	6.40	5.33	3.84	
L175070160		4.05	19.38	19.38	6.81	5.68	4.09	
L175070180		4.55	23.05	23.05	7.63	6.36	4.58	
L175070200		5.08	26.58	26.58	8.44	7.04	5.06	
L175070220		5.56	29.95	29.51	9.24	7.70	5.55	
L175070250		6.35	34.77	33.16	10.41	8.68	6.25	
L205070120		3.29	14.04	14.04	7.42	6.19	4.45	
L205070130		3.58	16.21	16.21	8.03	6.70	4.82	
L205070140		3.84	18.42	18.42	8.64	7.20	5.19	
L205070150		4.13	20.66	20.66	9.25	7.71	5.55	
L205070160		4.41	22.91	22.91	9.85	8.21	5.91	
L205070170		4.67	25.13	25.13	10.45	8.71	6.27	
L205070180		4.96	27.35	27.35	11.04	9.20	6.63	
L205070200		5.53	31.64	31.64	12.22	10.18	7.33	
5.00		L175070120	3.02	10.88	10.88	4.16	3.47	2.49
	L175070130	3.29	12.48	12.48	4.50	3.75	2.70	
	L175070140	3.52	14.12	14.12	4.84	4.04	2.91	
	L175070150	3.79	15.78	15.78	5.19	4.32	3.11	
	L175070160	4.05	17.45	17.45	5.52	4.60	3.31	
	L175070180	4.55	20.75	20.69	6.19	5.15	3.71	
	L175070200	5.08	23.92	22.84	6.84	5.70	4.10	
	L175070220	5.56	26.96	24.92	7.48	6.24	4.49	
	L175070250	6.35	31.30	28.02	8.44	7.03	5.06	
	L205070120	3.29	12.64	12.64	6.01	5.01	3.61	
	L205070130	3.58	14.59	14.59	6.51	5.42	3.91	
	L205070140	3.84	11.58	11.58	7.00	5.84	4.20	
	L205070150	4.13	18.60	18.60	7.49	6.24	4.50	
	L205070160	4.41	20.62	20.62	7.98	6.65	4.79	
	L205070170	4.67	22.62	22.62	8.46	7.05	5.08	
	L205070180	4.96	24.61	24.61	8.95	7.46	5.37	
	L205070200	5.53	28.47	27.98	9.90	8.25	5.94	

Multichannel - Load Tables

Multichannel Brickwork Restraint

Table 4:7 Multichannel Brickwork Restraint Single Span Cont.

Span (m)	Section	Weight kg/m	Ultimate Uniformly Distributed Load (kN)		Working Load to Produce Deflection of			
			Pressure	Suction	span/300 kN	span/360 kN	span/500 kN	
5.5	L175070120	3.02	9.89	9.89	3.44	2.86	2.06	
	L175070130	3.29	11.34	11.34	3.72	3.10	2.23	
	L175070140	3.52	12.83	12.83	4.01	3.34	2.40	
	L175070150	3.79	14.35	14.35	4.28	3.57	2.57	
	L175070160	4.05	15.86	15.50	4.56	3.80	2.74	
	L175070180	4.55	13.36	17.33	5.11	4.26	3.07	
	L175070200	5.08	21.75	19.13	5.65	4.71	3.39	
	L175070220	5.56	24.50	20.89	6.19	5.16	3.71	
	L175070250	6.35	28.45	23.49	6.97	5.81	4.18	
	L205070120	3.29	11.48	11.48	4.97	4.14	2.98	
	L205070130	3.58	13.26	13.26	5.38	4.48	3.23	
	L205070140	3.84	15.07	15.07	5.79	4.82	3.47	
	L205070150	4.13	16.90	16.90	6.19	5.16	3.72	
	L205070160	4.41	18.74	18.74	6.60	5.50	3.96	
	L205070170	4.67	20.56	20.09	7.00	5.83	4.20	
	L205070180	4.96	22.37	21.20	7.39	6.16	4.43	
	L205070200	5.53	25.88	23.39	8.18	6.82	4.91	
	6.0	L175070150	3.79	13.15	12.11	3.60	3.00	2.16
		L175070160	4.05	14.54	12.88	3.83	3.19	2.30
		L175070180	4.55	17.29	14.41	4.30	3.58	2.58
L175070200		5.08	19.93	15.91	4.75	3.96	2.85	
L175070220		5.56	22.46	17.39	5.20	4.33	3.12	
L175070250		6.35	20.08	19.57	5.86	4.88	3.52	
L205070120		3.29	10.53	10.53	4.17	3.48	2.50	
L205070130		3.58	12.16	12.16	4.52	3.77	2.71	
L205070140		3.84	13.82	13.82	4.86	4.05	2.92	
L205070150		4.13	15.49	14.81	5.20	4.33	3.12	
L205070160		4.41	17.18	15.74	5.54	4.62	3.33	
L205070170		4.67	18.85	16.67	5.88	4.90	3.52	
L205070180		4.96	20.51	17.60	6.21	5.18	3.73	
L205070200		5.53	23.72	19.42	6.87	5.73	4.12	
6.5	L175070150	3.79	12.14	11.64	3.07	2.56	1.84	
	L175070160	4.05	13.42	12.37	3.27	2.72	1.96	
	L175070180	4.55	15.96	13.83	3.66	3.05	2.20	
	L175070200	5.08	18.40	15.26	4.05	3.37	2.43	
	L175070220	5.56	20.74	16.65	4.43	3.69	2.66	
	L175070250	6.35	24.07	18.70	4.99	4.16	2.99	
	L205070120	3.29	9.72	9.72	3.56	2.96	2.13	
	L205070130	3.58	11.22	11.22	3.85	3.21	2.31	
	L205070140	3.84	12.75	12.75	4.14	3.45	2.49	
	L205070150	4.13	14.30	14.27	4.43	3.69	2.66	
	L205070160	4.41	15.85	15.17	4.72	3.94	2.83	
	L205070170	4.67	17.40	16.06	5.01	4.17	3.01	
	L205070180	4.96	18.93	16.95	5.29	4.41	3.18	
	L205070200	5.53	21.90	18.69	5.86	4.88	3.51	
L205070220	6.05	24.76	21.57	6.41	5.34	3.85		
L205070250	6.91	28.88	22.91	7.23	6.02	4.34		
7.0	L175070150	3.79	11.27	9.93	2.64	2.20	1.59	
	L175070160	4.05	12.46	10.55	2.81	2.35	1.69	
	L175070180	4.55	14.82	11.79	3.16	2.63	1.89	
	L175070200	5.08	17.09	13.01	3.49	2.91	2.09	
	L175070220	5.56	19.26	14.20	3.82	3.18	2.29	
	L175070250	6.35	22.35	15.95	4.30	3.59	2.58	
	L205070120	3.29	9.02	9.02	3.07	2.56	1.84	
	L205070130	3.58	10.42	10.42	3.32	2.77	1.99	
	L205070140	3.84	11.84	11.38	3.57	2.98	2.14	
	L205070150	4.13	13.28	12.16	3.82	3.18	2.30	
	L205070160	4.41	14.72	12.93	4.07	3.39	2.44	
	L205070170	4.67	16.16	13.69	4.32	3.60	2.59	
	L205070180	4.96	17.58	14.44	4.56	3.80	2.74	
	L205070200	5.53	20.34	15.93	5.05	4.21	3.03	
L205070220	6.05	23.00	17.38	5.53	4.61	3.32		
L205070250	6.91	26.82	19.51	6.24	5.19	3.74		

Table 4:7 Multichannel Brickwork Restraint Double Span

Span (m)	Section	Weight kg/m	Ultimate Uniformly Distributed Load (kN)		Working Load to Produce Deflection of		
			Pressure	Suction	span/300 kN	span/360 kN	span/500 kN
4.0	L175070120	3.02	11.07	11.07	15.66	13.05	9.40
	L175070130	3.29	13.35	13.35	16.95	14.13	10.17
	L175070140	3.52	15.75	15.75	18.24	15.20	10.94
	L175070150	3.79	18.24	18.24	19.51	16.26	11.71
	L175070160	4.05	20.77	20.77	20.77	17.31	12.46
	L175070180	4.55	25.88	25.88	23.28	19.40	13.97
	L175070200	5.08	30.85	30.85	25.74	21.45	15.45
	L175070220	5.56	35.60	35.60	28.17	23.48	16.90
	L175070250	6.35	42.30	42.30	31.75	26.46	19.05
	L205070120	3.29	10.85	10.85	22.62	18.85	13.57
	L205070130	3.58	13.34	13.34	24.50	20.41	14.70
	L205070140	3.84	16.03	16.03	26.35	21.96	15.81
	L205070150	4.13	18.89	18.89	28.20	23.50	16.92
	L205070160	4.41	21.87	21.87	30.03	25.03	18.02
	L205070170	4.67	24.93	24.93	31.86	26.55	19.11
	L205070180	4.96	28.04	28.04	33.67	28.05	20.20
	L205070200	5.53	34.25	34.25	37.25	31.04	22.35
4.5	L175070120	3.02	9.22	9.22	12.38	10.31	7.43
	L175070130	3.29	11.05	11.05	13.40	11.16	8.04
	L175070140	3.52	12.96	12.96	14.41	12.01	8.65
	L175070150	3.79	14.93	14.93	15.42	12.85	9.25
	L175070160	4.05	16.92	16.92	16.41	13.68	9.85
	L175070180	4.55	20.93	20.93	18.39	15.33	11.03
	L175070200	5.08	24.80	24.80	20.34	16.95	12.20
	L175070220	5.56	28.49	28.49	22.26	18.55	13.36
	L175070250	6.35	33.69	33.69	25.08	20.90	15.05
	L205070120	3.29	9.20	9.20	17.88	14.90	10.73
	L205070130	3.58	11.25	11.25	19.35	16.13	11.61
	L205070140	3.84	13.43	13.43	20.82	17.35	12.49
	L205070150	4.13	15.74	15.74	22.28	18.57	13.37
	L205070160	4.41	18.12	18.12	23.73	19.77	14.24
	L205070170	4.67	20.55	20.55	25.17	20.97	15.10
	L205070180	4.96	23.00	23.00	26.60	22.17	15.96
	L205070200	5.53	27.86	27.86	29.43	24.53	17.66
5.0	L175070120	3.02	8.65	8.65	10.02	8.35	6.01
	L175070130	3.29	10.31	10.31	10.85	9.04	6.51
	L175070140	3.52	12.03	12.03	11.67	9.73	7.00
	L175070150	3.79	13.80	13.80	12.49	10.41	7.49
	L175070160	4.05	15.59	15.59	13.29	11.08	7.98
	L175070180	4.55	19.16	19.16	14.90	12.41	8.94
	L175070200	5.08	22.60	22.60	16.47	13.73	9.88
	L175070220	5.56	25.87	25.87	18.03	15.02	10.82
	L175070250	6.35	30.50	30.50	20.32	16.93	12.19
	L205070120	3.29	8.77	8.77	14.48	12.07	8.69
	L205070130	3.58	10.66	10.66	15.68	13.06	9.41
	L205070140	3.84	12.67	12.67	16.87	14.06	10.12
	L205070150	4.13	14.77	14.77	18.05	15.04	10.83
	L205070160	4.41	16.92	16.92	19.22	16.02	11.53
	L205070170	4.67	19.11	19.11	20.39	16.99	12.23
	L205070180	4.96	21.31	21.31	21.55	17.96	12.93
	L205070200	5.53	25.63	25.63	23.84	19.87	14.30
5.5	L175070120	3.02	8.13	8.13	8.28	6.90	4.97
	L175070130	3.29	9.64	9.64	8.97	7.47	5.38
	L175070140	3.52	11.21	11.21	9.65	8.04	5.79
	L175070150	3.79	12.81	12.81	10.32	8.60	6.19
	L175070160	4.05	14.43	14.43	10.99	9.16	6.59
	L175070180	4.55	17.64	17.64	12.31	10.26	7.39
	L175070200	5.08	20.74	20.74	13.62	11.35	8.17
	L175070220	5.56	23.68	23.34	14.90	12.42	8.94
	L175070250	6.35	27.85	26.58	16.79	13.99	10.08
	L205070120	3.29	8.36	8.36	11.97	9.97	7.18
	L205070130	3.58	10.11	10.11	12.96	10.80	7.77
	L205070140	3.84	11.96	11.96	13.94	11.62	8.36
	L205070150	4.13	13.88	13.88	14.92	12.43	8.95
	L205070160	4.41	15.73	14.87	15.89	13.24	9.53
	L205070170	4.67	17.82	16.73	16.85	14.04	10.11
	L205070180	4.96	19.80	18.49	17.81	14.84	10.68
	L205070200	5.53	23.69	20.98	19.70	16.42	11.82

Multichannel - Load Tables

Table 4:7 Multichannel Brickwork Restraint Double Span Cont.

Span (m)	Section	Weight kg/m	Ultimate Uniformly Distributed Load (kN)		Working Load to Produce Deflection of		
			Pressure	Suction	span/300 kN	span/360 kN	span/500 kN
6.0	L175070150	3.79	11.94	11.94	8.67	7.23	5.20
	L175070160	4.05	13.41	13.41	9.23	7.69	5.54
	L175070180	4.55	16.34	16.34	10.35	8.62	6.21
	L175070200	5.08	19.15	19.15	11.44	9.53	6.86
	L175070220	5.56	21.82	21.82	12.52	10.43	7.51
	L175070250	6.35	25.61	25.61	14.11	11.76	8.47
	L205070120	3.29	7.97	7.97	10.05	8.38	6.03
	L205070130	3.58	9.59	9.59	10.89	9.07	6.53
	L205070140	3.84	11.30	11.30	11.71	9.76	7.03
	L205070150	4.13	13.06	13.06	12.53	10.44	7.52
	L205070160	4.41	14.86	14.86	13.35	11.12	8.01
	L205070170	4.67	16.67	16.67	14.16	11.80	8.49
	L205070180	4.96	18.47	18.47	14.96	12.47	8.98
	L205070200	5.53	22.00	21.52	16.55	13.80	9.93
	6.5	L175070150	3.79	11.17	11.17	7.39	6.16
L175070160		4.05	12.52	12.52	7.87	6.56	4.72
L175070180		4.55	15.20	15.20	8.81	7.35	5.29
L175070200		5.08	17.78	17.78	9.75	8.12	5.85
L175070220		5.56	20.23	20.23	10.67	8.89	6.40
L175070250		6.35	23.71	23.71	12.02	10.02	7.21
L205070120		3.29	7.60	7.60	8.57	7.14	5.14
L205070130		3.58	9.11	9.11	9.28	7.73	5.57
L205070140		3.84	10.69	10.69	9.98	8.32	5.99
L205070150		4.13	12.32	12.32	10.68	8.90	6.41
L205070160		4.41	13.98	13.98	11.37	9.48	6.82
L205070170		4.67	15.64	15.64	12.06	10.05	7.24
L205070180		4.96	17.30	17.30	12.75	10.62	7.65
L205070200		5.53	20.52	20.52	14.11	11.75	8.46
L205070220		6.05	23.62	23.62	15.44	12.87	9.27
L205070250	6.91	28.03	28.03	17.42	14.51	10.45	
7.0	L175070150	3.79	10.48	10.48	6.37	5.31	3.82
	L175070160	4.05	11.73	11.73	6.78	5.65	4.07
	L175070180	4.55	14.20	14.20	7.60	6.33	4.56
	L175070200	5.08	16.58	16.58	8.41	7.00	5.04
	L175070220	5.56	18.84	18.84	9.20	7.67	5.52
	L175070250	6.35	22.06	22.06	10.37	8.64	6.22
	L205070120	3.29	7.25	7.25	7.39	6.16	4.43
	L205070130	3.58	8.67	8.67	8.00	6.67	4.80
	L205070140	3.84	10.14	10.14	8.61	7.17	5.16
	L205070150	4.13	11.66	11.66	9.21	7.67	5.53
	L205070160	4.41	13.19	13.19	9.81	8.17	5.88
	L205070170	4.67	14.72	14.72	10.40	8.67	6.24
	L205070180	4.96	16.25	16.25	10.99	9.16	6.60
	L205070200	5.53	19.22	19.22	12.16	10.14	7.30
	L205070220	6.05	22.07	22.07	13.32	11.10	7.99
L205070250	6.91	26.13	26.13	15.02	12.51	9.01	

Rafter and Stanchion Stays

Length between c/c holes mm	RNB Angle 45 x 45	RNA Channel 38 x 38 x 38
	Ultimate compression kN	Ultimate compression kN
500	17.54	31.4
600	17.05	31.4
700	16.55	31.4
800	16.1	31.4
900	15.75	31.4
1000	15.55	31.4
1500	-	21
2000	-	15.5

Horizontal Panel Vertical Support Member (G140/150)

Span (m)	Ultimate Pressure	Ultimate Suction	Deflection L/150
	Kn	Kn	Kn
3.0	23.44	9.21	9.10
3.5	19.66	7.72	6.69
4.0	16.73	6.58	5.12
4.5	14.33	6.68	4.05

NOTE: Stay attaches to Multichannel/Multibeam with an M12 (8.8 grade) bolt and to the hot-rolled steel with a M16 bolt.

Multichannel Cladding Rails

Ultimate Loads

Multichannel used as cladding rail supports, sections supported on Multichannel cleats as shown in the Multibeam Handbook
LOADS SHOWN ARE UDL'S IN kN AND ARE ULTIMATE VALUES.

Values against deflection should be compared against values at working load. Loading assumes cladding provides restraint to the Multichannel, and that the Multichannel restraint system as detailed in the Multibeam Handbook is used. Lining and levelling of the bottom base rails should be completed before fitting further rails or tube struts. Maximum height limit 10m.

Table 4:8 Double Span Cladding Rails (Vertical Cladding)

Span (m)	Siderail Section	Weight kg/m	Ultimate Uniformly Distributed Load (kN)		Working Load to Produce Deflection of Span/150	Span (m)	Siderail Section	Weight kg/m	Ultimate Uniformly Distributed Load (kN)		Working Load to Produce Deflection of Span/150
			Pressure	Suction					Pressure	Suction	
4.0	L145070120	2.75	9.39	9.39	19.83	6.0	L145070140	3.21	9.08	9.08	10.26
	L145070130	2.99	11.06	11.06	21.47		L145070150	3.45	10.23	10.23	10.97
	L145070140	3.21	12.79	12.79	23.08		L145070160	3.69	11.38	11.38	11.68
	L145070150	3.45	14.56	14.56	24.69		L145070180	4.15	13.65	13.19	13.08
	L145070160	3.69	16.33	16.33	26.28		L145070200	4.63	15.83	14.69	14.46
	L145070180	4.15	19.85	19.85	29.43		L145070220	5.06	17.89	16.15	15.83
	L145070200	4.63	23.22	23.22	32.53		L175070120	3.02	7.65	7.65	13.59
4.5	L145070220	5.06	26.41	26.41	35.61	L175070130	3.29	9.04	9.04	14.71	
	L145070120	2.75	8.62	8.62	15.67	L175070140	3.52	10.48	10.48	15.82	
	L145070130	2.99	10.1	10.1	16.96	L175070150	3.79	11.94	11.94	16.93	
	L145070140	3.21	11.63	11.63	18.24	L175070160	4.05	13.41	13.41	18.03	
	L145070150	3.45	13.19	13.19	19.51	L175070180	4.55	16.34	16.22	20.2	
	L145070160	3.69	14.75	14.75	20.76	L175070200	5.08	19.15	18.25	22.34	
	L145070180	4.15	17.85	17.85	23.25	L205070120	3.29	7.97	7.97	19.63	
5.0	L145070200	4.63	20.82	20.82	25.7	L205070130	3.58	9.59	9.59	21.26	
	L145070220	5.06	23.62	23.62	28.14	L205070140	3.84	11.3	11.3	22.87	
	L145070120	2.75	7.95	7.95	12.69	L205070150	4.13	13.06	13.06	24.47	
	L145070130	2.99	9.28	9.28	13.74	L175070150	3.79	11.17	11.17	14.43	
	L145070140	3.21	10.65	10.65	14.77	L175070160	4.05	12.52	12.52	11.03	
	L145070150	3.45	12.04	12.04	15.8	L175070180	4.55	15.52	15.52	17.21	
	L145070160	3.69	13.44	13.44	16.82	L175070200	5.08	17.78	17.78	19.03	
5.5	L145070180	4.15	16.2	16.2	18.83	L205070120	3.29	7.6	7.6	16.73	
	L145070200	4.63	18.85	18.85	20.82	L205070130	3.58	9.11	9.11	18.11	
	L145070220	5.06	21.35	21.35	22.79	L205070140	3.84	10.69	10.69	19.48	
	L175070120	3.02	8.62	8.62	19.57	L205070150	4.13	12.32	12.32	20.85	
	L175070130	3.29	10.31	10.31	21.19	L205070160	4.41	13.98	13.98	22.2	
	L175070140	3.52	12.03	12.03	22.79	L205070170	4.67	15.64	15.64	23.55	
	L175070150	3.79	13.8	13.8	24.38	L205070180	4.96	17.3	17.3	24.89	
7.0	L145070120	2.75	7.36	7.36	10.49	L205070200	5.53	20.52	20.52	27.54	
	L145070130	2.99	8.57	8.57	11.35	L235070130	3.86	9.28	9.28	24.96	
	L145070140	3.21	9.81	9.81	12.21	L235070140	4.14	11.07	11.07	26.86	
	L145070150	3.45	11.07	11.07	13.06	L235070150	4.45	12.94	12.94	28.74	
	L145070160	3.69	12.33	12.33	13.9	L235070160	4.76	14.87	14.87	30.62	
	L145070180	4.15	14.82	14.82	15.57	L235070170	5.04	16.83	16.83	32.48	
	L145070200	4.63	17.21	17.02	17.2	L235070180	5.35	18.8	18.8	34.33	
	L145070220	5.06	19.47	18.74	18.84	L235070200	5.97	22.72	22.72	38.87	
	L175070120	3.02	8.13	8.13	16.17	L205070120	3.29	7.25	7.25	14.42	
	L175070130	3.29	9.64	9.64	17.51	L205070130	3.58	8.67	8.67	15.62	
	L175070140	3.52	11.21	11.21	18.83	L205070140	3.84	10.14	10.14	16.8	
	L175070150	3.79	12.81	12.81	20.15	L205070150	4.13	11.66	11.66	17.98	
	L175070160	4.05	14.43	14.43	21.45	L205070160	4.41	13.19	13.19	19.15	
	L175070180	4.55	17.64	17.64	22.57	L205070170	4.67	14.72	14.72	20.31	
	L175070200	5.08	20.74	20.74	26.58	L205070180	4.96	16.25	16.25	21.46	
						L205070200	5.53	19.22	19.22	23.75	
						L235070130	3.86	8.91	8.91	21.52	
					L235070140	4.14	10.58	10.58	23.16		
					L235070150	4.45	12.33	12.33	24.78		
					L235070160	4.76	14.13	14.13	26.4		
					L235070170	5.04	15.95	15.95	28.01		
					L235070180	5.35	17.78	17.78	29.6		
					L235070200	5.97	21.39	21.39	32.76		

Multichannel - Load Tables

Table 4:9 Double span Cladding Rails (Horizontal Cladding)

Span (m)	Siderail Section	Weight kg/m	Ultimate Uniformly Distributed Load (kN)		Working Load to Produce Deflection of Span/150
			Pressure	Suction	
4.0	L145070120	2.75	12.83	12.83	23.01
	L145070130	2.99	15.06	15.06	24.9
	L145070140	3.21	17.38	17.38	26.77
	L145070150	3.45	19.77	19.77	28.64
	L145070160	3.69	22.19	22.19	30.48
	L145070180	4.15	27.04	27.04	34.14
	L145070200	4.63	31.76	31.76	37.73
4.5	L145070220	5.06	36.29	36.29	41.31
	L145070120	2.75	11.79	11.79	18.18
	L145070130	2.99	13.8	13.8	19.67
	L145070140	3.21	15.89	15.89	21.16
	L145070150	3.45	18.02	18.02	22.63
	L145070160	3.69	20.18	20.18	24.08
	L145070180	4.15	24.51	24.51	26.97
5.0	L145070200	4.63	28.71	28.71	29.81
	L145070220	5.06	32.72	32.72	32.64
	L145070120	2.75	10.91	10.91	14.72
	L145070130	2.99	12.73	12.73	15.94
	L145070140	3.21	14.62	14.62	17.14
	L145070150	3.45	16.55	16.55	18.33
	L145070160	3.69	18.5	18.5	19.51
5.5	L145070180	4.15	22.32	22.32	21.85
	L145070200	4.63	25.98	25.98	24.15
	L145070220	5.06	29.46	29.46	26.44
	L175070120	3.02	12.33	12.33	22.7
	L175070130	3.29	14.47	14.47	24.57
	L175070140	3.52	16.8	16.8	26.43
	L175070150	3.79	19.19	19.19	28.28
5.5	L145070120	2.75	10.11	10.11	12.17
	L145070130	2.99	11.7	11.7	13.17
	L145070140	3.21	13.35	13.35	14.16
	L145070150	3.45	15.03	15.03	15.15
	L145070160	3.69	16.71	16.71	16.12
	L145070180	4.15	20.06	20.06	18.06
	L145070200	4.63	23.29	23.29	19.96
	L145070220	5.06	26.37	26.37	21.85
	L175070120	3.02	11.46	11.46	18.76
	L175070130	3.29	13.51	13.51	20.31
	L175070140	3.52	15.65	15.65	21.84
	L175070150	3.79	17.78	17.78	23.37
	L175070160	4.05	19.88	19.88	24.88
	L175070180	4.55	24.06	24.06	27.88
L175070200	5.08	28.1	28.1	30.84	

Table 4:9 Double span Cladding Rails (Horizontal Cladding) Cont.

Span (m)	Siderail Section	Weight kg/m	Ultimate Uniformly Distributed Load (kN)		Working Load to Produce Deflection of Span/150	Span (m)	Siderail Section	Weight kg/m	Ultimate Uniformly Distributed Load (kN)		Working Load to Produce Deflection of Span/150		
			Pressure	Suction					Pressure	Suction			
6.0	Restraints at mid-span	L145070140	3.21	12.1	12.1	11.9	7.0	Restraints at 1/3 points	L205070120	3.29	10.99	10.99	15.39
		L145070150	3.45	13.6	13.6	12.73			L205070130	3.58	13	13	16.66
		L145070160	3.69	15.09	15.09	13.55			L205070140	3.84	15.07	15.07	17.92
		L145070180	4.15	18.05	18.05	15.17			L205070150	4.13	17.18	17.18	19.18
		L145070200	4.63	20.9	20.9	16.77			L205070160	4.41	19.14	19.14	20.43
		L145070220	5.06	23.62	23.62	18.36			L205070170	4.67	21.08	21.08	21.67
		L175070120	3.02	10.69	10.69	15.76			L205070180	4.96	23.02	23.02	22.9
		L175070130	3.29	12.47	12.47	17.07			L205070200	5.53	26.79	26.79	25.33
		L175070140	3.52	14.3	14.3	18.36			L235070130	3.86	13.83	13.83	22.9
		L175070150	3.79	16.16	16.16	19.64			L235070140	4.14	16.23	16.23	24.7
		L175070160	4.05	18.01	18.01	20.91			L235070150	4.45	18.7	18.7	26.44
		L175070180	4.55	21.71	21.71	23.43			L235070160	4.76	21.2	21.2	28.16
		L175070200	5.08	25.26	25.26	25.91			L235070170	5.04	23.72	23.72	29.88
		L205070120	3.29	11.56	11.56	22.77			L235070180	5.35	26.13	26.13	31.58
		L205070130	3.58	13.78	13.78	24.66			L235070200	5.97	30.58	30.58	34.95
L205070140	3.84	16.07	16.07	26.53	7.5	Restraints at 1/3 points	L205070120	3.29	10.34	10.34	13.4		
L205070150	4.13	18.3	18.3	28.39			L205070130	3.58	12.2	12.2	14.51		
L145070140	3.21	13.01	13.01	10.94			L205070140	3.84	14.07	14.07	15.56		
L145070150	3.45	14.59	14.59	11.71			L205070150	4.13	15.86	15.86	16.71		
L145070160	3.69	16.18	16.18	12.46			L205070160	4.41	17.65	17.65	17.79		
L145070180	4.15	19.32	19.32	13.95			L205070170	4.67	19.42	19.42	18.87		
L145070200	4.63	22.35	22.35	15.42			L205070180	4.96	21.18	21.18	19.95		
L145070220	5.06	25.23	25.23	16.89			L205070200	5.53	24.61	24.61	22.07		
L175070120	3.02	11.32	11.32	14.5			L235070130	3.86	13.06	13.06	20		
L175070130	3.29	13.28	13.28	15.7			L235070140	4.14	15.29	15.29	21.52		
L175070140	3.52	15.29	15.29	16.88			L235070150	4.45	17.56	17.56	23.03		
L175070150	3.79	17.36	17.36	18.06			L235070160	4.76	19.86	19.86	24.53		
L175070160	4.05	19.42	19.42	19.23			L235070170	5.04	22	22	26.03		
L175070180	4.55	23.45	23.45	21.55			L235070180	5.35	24.07	24.07	27.51		
L175070200	5.08	27.23	27.23	23.83			L235070200	5.97	28.11	28.11	30.45		
L205070120	3.29	12.26	12.26	20.94	8.0	Restraints at 1/4 points	L205070150	4.13	14.66	14.66	14.68		
L205070130	3.58	14.6	14.6	22.68			L205070160	4.41	16.28	16.28	15.64		
L205070140	3.84	17.03	17.03	24.4			L205070170	4.67	17.9	17.9	16.59		
L205070150	4.13	19.52	19.52	26.11			L205070180	4.96	19.5	19.5	17.53		
L175070150	3.79	16.12	16.12	15.39			L205070200	5.53	22.61	22.61	19.4		
L175070160	4.05	17.91	17.91	16.39			L235070130	3.86	12.33	12.33	17.58		
L175070180	4.55	21.46	21.46	18.36			L235070140	4.14	14.39	14.39	18.91		
L175070200	5.08	24.89	24.89	20.31			L235070150	4.45	16.49	16.49	20.24		
L205070120	3.29	11.62	11.62	17.85			L235070160	4.76	18.4	18.4	21.56		
L205070130	3.58	13.79	13.79	19.32			L235070170	5.04	20.3	20.3	22.88		
L205070140	3.84	16.04	16.04	20.79			L235070180	5.35	22.18	22.18	24.18		
L205070150	4.13	18.34	18.34	22.24			L235070200	5.97	25.85	25.85	26.76		
L205070160	4.41	20.66	20.66	23.69			8.5	Restraints at 1/3 points	L235070130	3.86	11.62	11.62	15.57
L205070170	4.67	22.94	22.94	25.13					L235070140	4.14	13.49	13.49	16.75
L205070180	4.96	25.06	25.06	26.56					L235070150	4.45	15.22	15.22	17.93
L205070200	5.53	29.22	29.22	29.38	L235070160	4.76			16.96	16.96	19.1		
L235070130	3.86	11.15	11.15	26.63	L235070170	5.04			18.67	18.67	20.26		
L235070140	4.14	13.51	13.51	28.65	L235070180	5.35			20.37	20.37	21.42		
L235070150	4.45	15.9	15.9	30.66	L235070200	5.97			23.67	23.67	23.71		
L235070160	4.76	22.62	22.62	32.66	L235070220	6.53			26.85	26.85	25.96		
L235070170	5.04	25.37	25.37	34.65	L235070250	7.46			31.43	31.43	29.3		
L235070180	5.35	28.12	28.12	36.63	L235070270	8.08			34.37	34.37	31.48		
L235070200	5.97	33.31	33.31	40.54	L265070140	4.46			14.31	14.31	22.28		
					L265070150	4.79			16.51	16.51	23.84		
					L265075160	5.13			17.18	17.18	25.4		
					L265070180	5.76			22.64	22.64	28.49		
					L265070200	6.43			26.47	26.47	31.55		
					L265070220	7.03	30.18	30.18	34.56				
					L265070250	8.03	35.54	35.54	39.02				
					L265070270	8.70	38.99	38.99	41.94				

Multichannel

Multichannel - Load Tables

Single Span Load Tables for Multichannel Floor Beams

Ultimate Loads

Load tables are for Multichannels used as secondary floor beams. These can be fixed in one of three ways:

Between support steelwork. Over support steelwork fixed with or without Multibeam cleats (single or double span).

ALL LOADS SHOWN ARE ULTIMATE. VALUES SHOWN FOR DEFLECTION SHOULD BE COMPARED AGAINST APPLIED VALUES AT WORKING LOAD.

Loading assumes deck provides restraint to Multichannels and Multichannel restraints are provided at mid-span before placement of the deck. The deck should be suitably attached at the edge to restrain the floor (not applicable to Multichannel fixed over steel with cleats).

Multichannels must be fixed heel to heel and toe to toe. See construction details in the Multibeam Handbook.

Table 4:10 Multichannel Floor Beams Single Span Between Steel

Span (m)	Section	Weight kg/m	Ultimate Allowable Load kN	Deflection Limit L/250 kN	Deflection Limit L/360 kN	
3.0	L145070120	2.75	14.93	8.78	7.32	
	L145070130	2.99	17.04	9.51	7.92	
	L145070140	3.21	19.22	10.22	8.52	
	L145070150	3.45	21.43	10.93	9.11	
	L145070160	3.69	23.64	11.64	9.70	
	L145070180	4.15	28.04	13.03	10.86	
	L145070200	4.63	32.25	14.41	12.00	
	L175070120	3.02	17.84	13.54	11.28	
	L175070130	3.29	20.80	14.66	12.21	
	L175070140	3.52	23.53	15.76	13.14	
	L175070150	3.79	26.30	16.87	14.05	
	L175070160	4.05	29.08	17.96	14.97	
	L175070180	4.55	34.58	20.12	16.77	
	L175070200	5.08	39.86	22.26	18.55	
3.5	L145070120	2.75	12.80	6.45	5.38	
	L145070130	2.99	14.61	6.98	5.82	
	L145070140	3.21	16.47	7.51	6.26	
	L145070150	3.45	18.37	8.03	6.69	
	L145070160	3.69	20.27	8.55	7.12	
	L145070180	4.15	24.03	9.57	7.98	
	L145070200	4.63	27.65	10.58	8.82	
	L175070120	3.02	15.54	9.95	8.29	
	L175070130	3.29	17.83	10.77	8.97	
	L175070140	3.52	20.17	11.58	9.65	
	L175070150	3.79	22.55	12.39	10.33	
	L175070160	4.05	24.92	13.19	11.00	
	L175070180	4.55	29.64	14.78	12.32	
	L175070200	5.08	34.17	16.35	13.62	
4.0	L145070120	2.75	11.20	4.94	4.12	
	L145070130	2.99	12.78	5.35	4.46	
	L145070140	3.21	14.41	5.75	4.79	
	L145070150	3.45	16.07	6.15	5.12	
	L145070160	3.69	17.73	6.55	5.45	
	L145070180	4.15	21.02	7.33	6.11	
	L145070200	4.63	24.19	8.10	6.75	
	L145070220	5.06	27.19	8.87	7.39	
	L175070120	3.02	13.60	7.62	6.35	
	L175070130	3.29	15.60	8.25	6.87	
	L175070140	3.52	17.65	8.87	7.39	
	L175070150	3.79	19.73	9.49	7.91	
	L175070160	4.05	21.81	10.10	8.42	
	L175070180	4.55	25.94	11.32	9.43	
L175070200	5.08	29.90	12.52	10.43		
L175070220	5.56	33.70	13.70	11.42		
L175070250	6.35	39.12	15.44	12.87		
4.5	L175070120	3.02	12.09	6.02	5.01	
	L175070130	3.29	13.86	6.51	5.43	
	L175070140	3.52	15.69	7.01	5.84	
	L175070150	3.79	17.54	7.50	6.25	
	L175070160	4.05	19.38	7.98	6.65	
	L175070180	4.55	23.05	8.94	7.45	
	5.0	L175070120	3.02	10.88	4.87	4.06
		L175070130	3.29	12.48	5.28	4.40
		L175070140	3.52	14.12	5.68	4.73
		L175070150	3.79	15.78	6.07	5.06
L175070160		4.05	17.45	6.47	5.39	
L175070180		4.55	20.75	7.24	6.04	
L175070200		5.08	23.92	8.01	6.68	
L175070220		5.56	26.96	8.77	7.31	
L175070250		6.35	31.30	9.88	8.23	
L205070120		3.29	12.64	7.04	5.87	
L205070130		3.58	14.59	7.62	6.35	
L205070140		3.84	16.58	8.20	6.84	
L205070150		4.13	18.60	8.78	7.31	
L205070160		4.41	20.62	9.35	7.79	
5.5	L205070120	3.29	11.48	5.82	4.85	
	L205070130	3.58	13.26	6.30	5.25	
	L205070140	3.84	15.07	6.78	5.65	
	L205070150	4.13	16.90	7.25	6.04	
	L205070160	4.41	18.74	7.72	6.44	
	L205070170	4.67	20.56	8.19	6.83	
	L205070180	4.96	22.37	8.66	7.22	
	L205070200	5.53	25.88	9.58	7.98	
	L205070220	6.05	29.27	10.49	8.74	
	L205070250	6.91	34.13	11.83	9.86	
	L205070270	7.49	37.27	12.71	10.59	
	6.0	L205070160	3.29	17.18	6.49	5.41
		L205070170	3.58	18.85	6.89	5.74
		L205070180	3.84	20.51	7.28	6.06
L205070200		4.13	23.72	8.05	6.71	
L205070220		4.41	26.83	8.81	7.35	
L205070250		4.67	31.29	9.94	8.28	
L205070270		4.96	34.16	10.68	8.90	
L235070130		3.86	13.75	7.30	6.08	
L235070140		4.14	15.71	7.85	6.54	
L235070150		4.45	17.70	8.40	7.00	
L235070160		4.76	19.69	8.95	7.46	
L235070170		5.04	21.67	9.49	7.91	
L235070180		5.35	23.63	10.04	8.36	
L235070200		5.97	27.46	11.11	9.26	
L235070220	6.53	31.16	12.17	10.14		
L235070250	7.46	36.53	13.73	11.44		
L235070270	8.08	40.01	14.75	12.29		

NOTE: Section self weight has not been subtracted from the loadings shown.

Single Span Load Tables for Multichannel Floor Beams

Table 4:11 Multichannel Floor Beams Single Span on Cleats

Span (m)	Section	Weight kg/m	Ultimate Allowable Load kN	Deflection Limit L/250 kN	Deflection Limit L/360 kN	
3.0	L145070120	2.75	14.93	8.78	7.32	
	L145070130	2.99	17.04	9.51	7.92	
	L145070140	3.21	19.22	10.22	8.52	
	L145070150	3.45	21.43	10.93	9.11	
	L145070160	3.69	23.64	11.64	9.70	
	L145070180	4.15	28.04	13.03	10.86	
	L145070200	4.63	32.25	14.41	12.00	
	L175070120	3.02	17.84	13.54	11.28	
	L175070130	3.29	20.80	14.66	12.21	
	L175070140	3.52	23.53	15.76	13.14	
	L175070150	3.79	26.30	16.87	14.05	
	L175070160	4.05	29.08	17.96	14.97	
	L175070180	4.55	34.58	20.12	16.77	
	L175070200	5.08	39.86	22.26	18.55	
	3.5	L145070120	2.75	12.80	6.45	5.38
		L145070130	2.99	14.61	6.98	5.82
L145070140		3.21	16.47	7.51	6.26	
L145070150		3.45	18.37	8.03	6.69	
L145070160		3.69	20.27	8.55	7.12	
L145070180		4.15	24.03	9.57	7.98	
L145070200		4.63	27.65	10.58	8.82	
L175070120		3.02	15.54	9.95	8.29	
L175070130		3.29	17.83	10.77	8.97	
L175070140		3.52	20.17	11.58	9.65	
L175070150		3.79	22.55	12.39	10.33	
L175070160		4.05	24.92	13.19	11.00	
L175070180		4.55	29.64	14.78	12.32	
L175070200		5.08	34.17	16.35	13.62	
4.0		L145070120	2.75	11.20	4.94	4.12
		L145070130	2.99	12.78	5.35	4.46
	L145070140	3.21	14.41	5.75	4.79	
	L145070150	3.45	16.07	6.15	5.12	
	L145070160	3.69	17.73	6.55	5.45	
	L145070180	4.15	21.02	7.33	6.11	
	L145070200	4.63	24.19	8.10	6.75	
	L145070220	5.06	27.19	8.87	7.39	
	L175070120	3.02	13.60	7.62	6.35	
	L175070130	3.29	15.60	8.25	6.87	
	L175070140	3.52	17.65	8.87	7.39	
	L175070150	3.79	19.73	9.49	7.91	
	L175070160	4.05	21.81	10.10	8.42	
	L175070180	4.55	25.94	11.32	9.43	
	L175070200	5.08	29.90	12.52	10.43	
	L175070220	5.56	33.70	13.70	11.42	
L175070250	6.35	39.12	15.44	12.87		
4.5	L175070120	3.02	12.09	6.02	5.01	
	L175070130	3.29	13.86	6.51	5.43	
	L175070140	3.52	15.69	7.01	5.84	
	L175070150	3.79	17.54	7.50	6.25	
	L175070160	4.05	19.38	7.98	6.65	
	L175070180	4.55	23.05	8.94	7.45	
	L175070200	5.08	26.58	9.89	8.24	
	L175070220	5.56	29.95	10.82	9.02	
	L175070250	6.35	34.77	12.20	10.17	
	L205070120	3.29	14.04	8.69	7.24	
	L205070130	3.58	16.21	9.41	7.84	
	L205070140	3.84	18.42	10.13	8.44	
	L205070150	4.13	20.66	10.84	9.03	
	L205070160	4.41	22.91	11.54	9.62	

Span (m)	Section	Weight kg/m	Ultimate Allowable Load kN	Deflection Limit L/250 kN	Deflection Limit L/360 kN	
5.0	L175070120	3.02	10.88	4.87	4.06	
	L175070130	3.29	12.48	5.28	4.40	
	L175070140	3.52	14.12	5.68	4.73	
	L175070150	3.79	15.78	6.07	5.06	
	L175070160	4.05	17.45	6.47	5.39	
	L175070180	4.55	20.75	7.24	6.04	
	L175070200	5.08	23.92	8.01	6.68	
	L175070220	5.56	26.96	8.77	7.31	
	L175070250	6.35	31.30	9.88	8.23	
	L205070120	3.29	12.64	7.04	5.87	
	L205070130	3.58	14.59	7.62	6.35	
	L205070140	3.84	16.58	8.20	6.84	
	L205070150	4.13	18.60	8.78	7.31	
	L205070160	4.41	20.62	9.35	7.79	
	5.5	L205070120	3.29	11.48	5.82	4.85
		L205070130	3.58	13.26	6.30	5.25
L205070140		3.84	15.07	6.78	5.65	
L205070150		4.13	16.90	7.25	6.04	
L205070160		4.41	18.74	7.72	6.44	
L205070170		4.67	20.56	8.19	6.83	
L205070180		4.96	22.37	8.66	7.22	
L205070200		5.53	25.88	9.58	7.98	
L205070220		6.05	29.27	10.49	8.74	
L205070250		6.91	34.13	11.83	9.86	
L205070270		7.49	37.27	12.71	10.59	
6.0		L205070160	3.29	17.18	6.49	5.41
		L205070170	3.58	18.85	6.89	5.74
		L205070180	3.84	20.51	7.28	6.06
		L205070200	4.13	23.72	8.05	6.71
		L205070220	4.41	26.83	8.81	7.35
	L205070250	4.67	31.29	9.94	8.28	
	L205070270	4.96	34.16	10.68	8.90	
	L235070130	3.86	13.75	7.30	6.08	
	L235070140	4.14	15.71	7.85	6.54	
	L235070150	4.45	17.70	8.40	7.00	
	L235070160	4.76	19.69	8.95	7.46	
	L235070170	5.04	21.67	9.49	7.91	
	L235070180	5.35	23.63	10.04	8.36	
	L235070200	5.97	27.46	11.11	9.26	
	L235070220	6.53	31.16	12.17	10.14	
	L235070250	7.46	36.53	13.73	11.44	
L235070270	8.08	40.01	14.75	12.29		

NOTE: Section self weight has not been subtracted from the loadings shown.

Ordering Methods

Preferred methods of ordering and detailing Kingspan Multibeam Purlin, Cladding Rail and Multichannel systems can be detailed and ordered using either of the following quick and simple methods as follows:

Kingspan Detailing and Ordering Software

Custom designed programme available to download from the Kingspan Structural website www.kingspanstructural.com or is available on the Toolkit CD which can be posted to you upon request.



When ordering with the Toolkit software please ensure details are supplied to Kingspan in the electronic transfer file format (.WTX)

Kingspan Direct Detailing

For users of Strucad or Tekla Structures 3D CAD software please ensure details are supplied to Kingspan Structural in the following electronic transfer file formats:



(.WDX) along with the cold rolled assembly list (.XSR)



(.WDO) along with the summary report file (.html/.ccf)

Any non-standard details must be supplied in 'pdf' format.

All the systems mentioned allow the user to incorporate the Kingspan Structural products shown in this literature. The electronic ordering details can be generated within these systems and sent to Kingspan Structural via email.

Manual Detailing

Purpose designed order/detail forms can be made available upon request for those customers who do not have access to electronic detailing software (Please see separate order pack ref P226).

Note: Technical assistance is available for all the electronic detailing systems, please contact our Technical Department direct on 01944 712000.

Eaves Beam Hole Arrangements and Options

For examples of hole and connection details please refer to the construction details section pages 52-57.

Cleader Angle Options – Please see page 31

Horizontal Panel Vertical Support Hole Arrangements and Options (G140/150)

Hole Arrangement – Please see pages 84 and 121.

For cleat connection details please refer to the construction details section pages 68, 69, 100 and 101.

Members can be supplied with or without end cleats assembled, see pages 68, 69, 100 and 101. (Additional 1 week lead time for assembled components.)

Ancillaries

For all fixing details please refer to the construction details sections.

Weld-on cleats are generally delivered to fabricator's own works. Transport charges do not normally apply to the delivery of cleats.

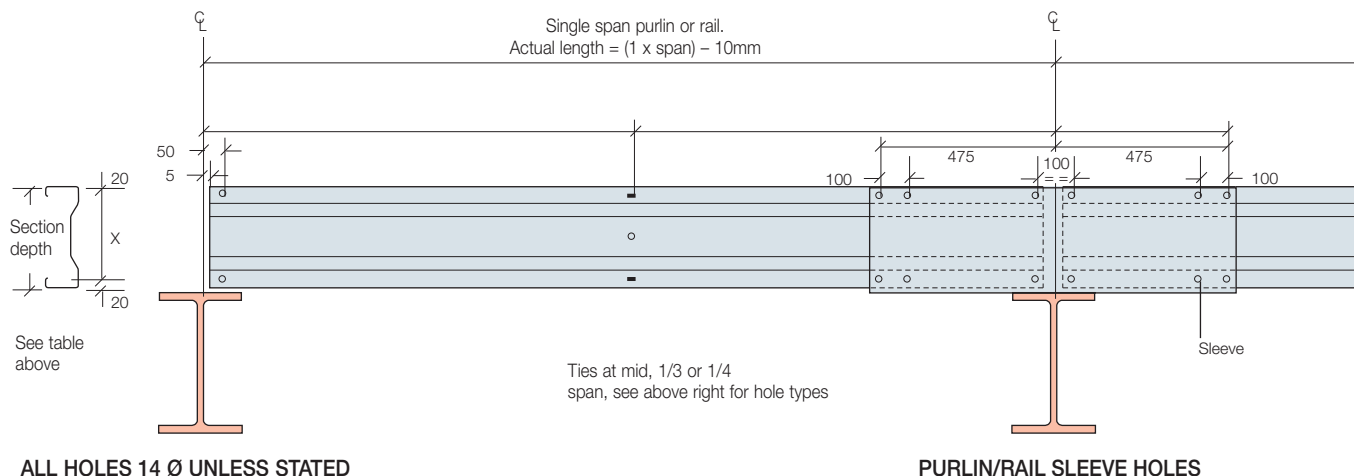

Multibeam Purlin and Rail Hole Arrangements and Options

Web Holes

See hole configurations below.

All holes Ø14 unless stated.

All web holes if not on centre line are to be detailed in pairs.

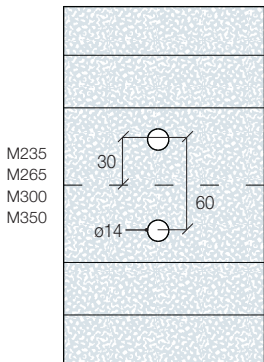
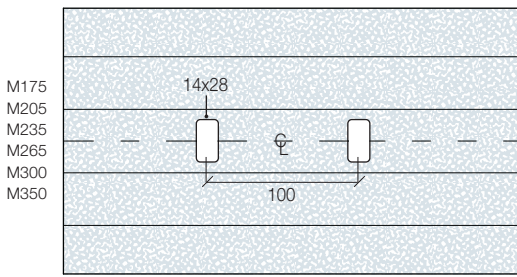
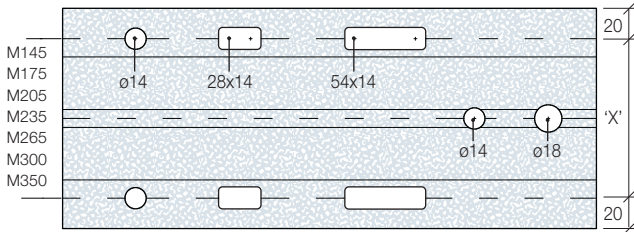

Further examples of hole details see layout below

Double span purlin or rail.
Actual length = (2 x span) - 10mm

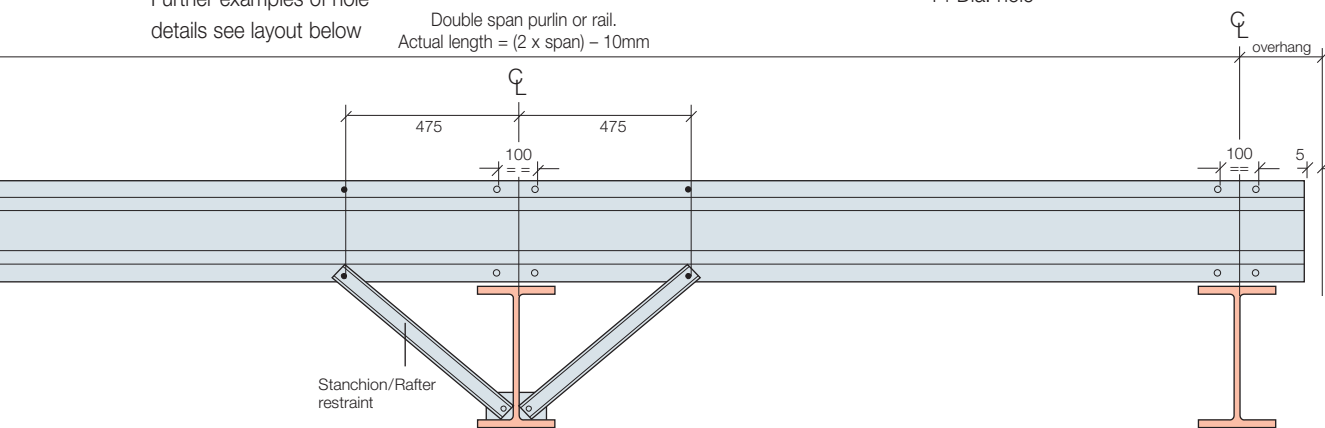

RAFTER/STANCHION STAY HOLES
(See above)

Standard holes are punched as shown below

Section Depth mm	145	175	205	235	265	300	350
Dim 'x' hole centres in mm	105	135	165	195	225	260	310

Flange Holes

Ø14 holes at 30mm backmark from heel of section.

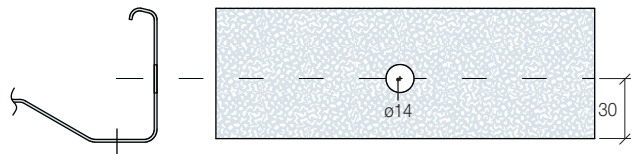

Purlin Tie Holes

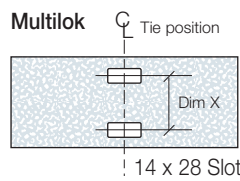

145

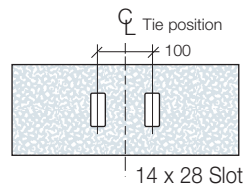

175
205

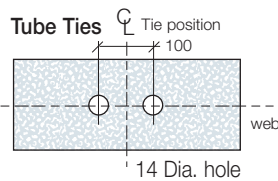

235
265
300
350

Rail Tie Holes

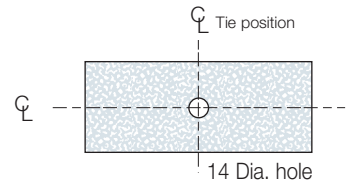

Ordering Methods

Multichannel Rail and Floor Beam Hole Arrangements and Options

Multichannel can be supplied with plain ends (ie. Cut to length), notched ends (top, bottom or both) or Autoform® Ends.

Web Holes

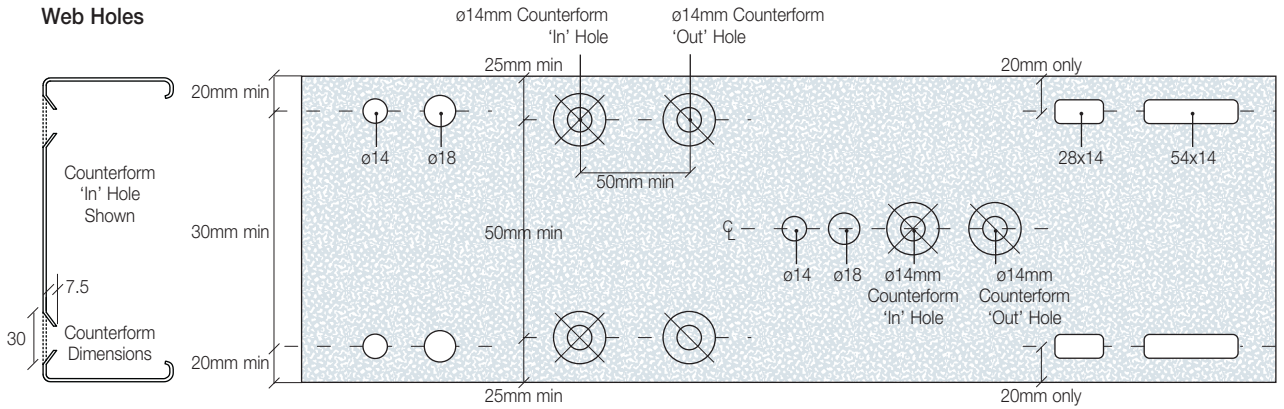

ø12mm holes available, please contact our Customer Services Department for details. Minimum channel length = 125mm

Flange Holes

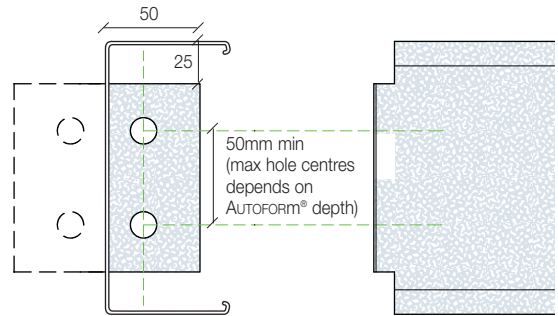
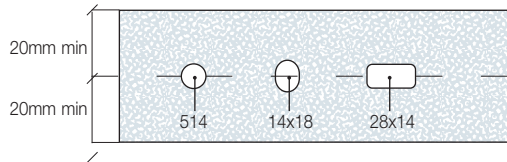

Hole group combination

When the number of hole groups exceed three combinations please contact Customer Service Department for availability.

Autoform® Ends

Autoform® Ends are available with the returns turned inward or outward, these can be punched or counterformed with standard hole options as required. These holes should be 20mm from the web for M12 bolts or 25mm from the web for M16 bolts or M12 counterform holes.

Standard Autoform® Ends are supplied with a 50mm return on all section sizes. Non-standard returns are available on request ranging from 50mm to 95mm.

Autoform Details

Min. Notch Depth	11mm
Max. Notch Depth	(see notch table)*
Min. Notch Length	11mm
Max. Notch Length	195mm
Min. Autoform Return	50mm
Max. Autoform Return	95mm
Min. Multichannel Length	125mm

* Autoform hole centres should be considered

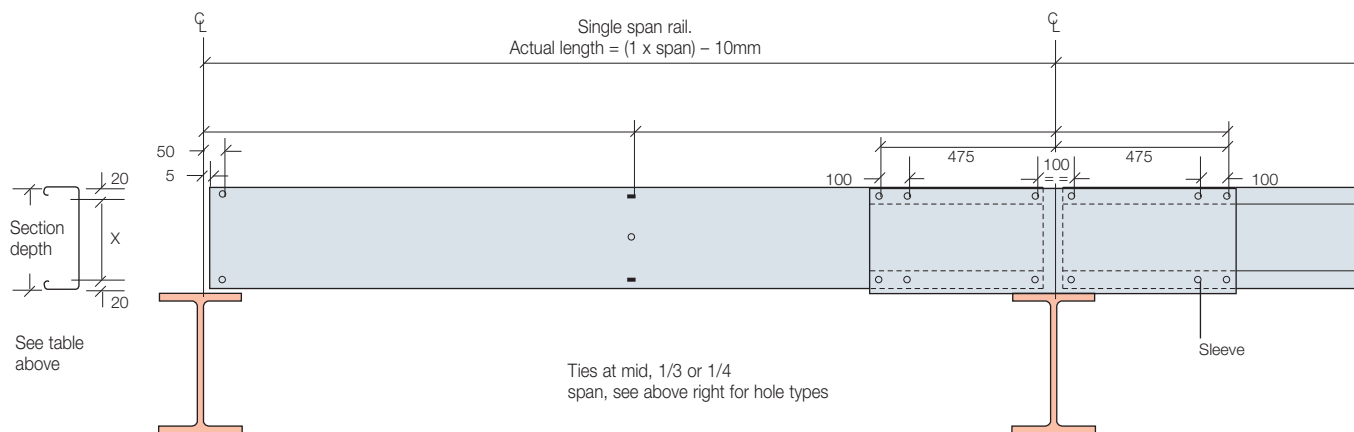

ALL HOLES 14 Ø UNLESS STATED

RAIL SLEEVE HOLES

Notching

Notches can be cut either top or bottom or both. Standard notches are 25mm in depth cut to the lengths shown below.

Notch depths on each flange must match, ie. Top Lead end 50mm; Tail end 50mm; Bottom Lead end 25mm; Tail end 25mm.

Non-standard notches can be cut subject to quantity, please contact our Sales Department for details.

Hole Arrangements

Minimum backmark 20mm (Counterform holes min 25mm backmark).

Paired holes available minimum 50mm centres.

14mm x 28mm and 14mm x 54mm slotted holes only available 20mm backmark.

For further examples of hole details please see below.

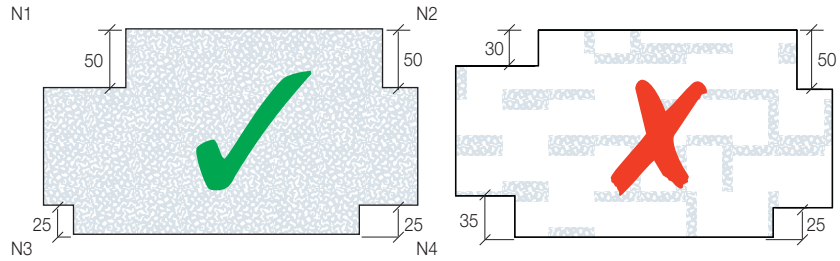

Notch Details

	Section	Min. (mm)	Max. (mm)
Notch Length	All	30	250
	145	11	48
	175	11	61
Notch Depth	205	11	76
	235	11	*
	265	11	*
	300	11	*
	350	11	*

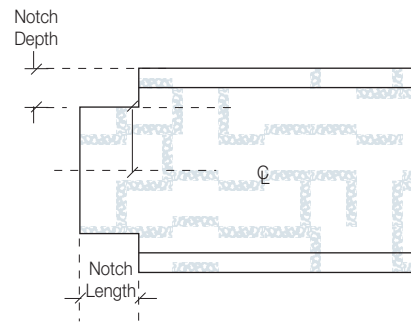

*For maximum notch depth please contact our Customer Service Department

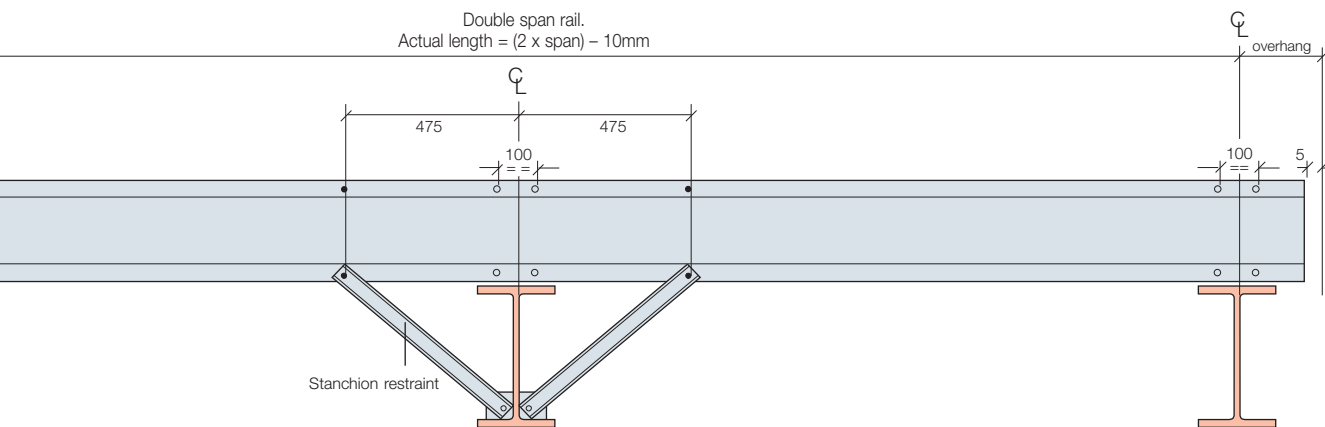

STANCHION STAY HOLES
(See above)

Case Studies

Colburn Business Park, Catterick

Utilising over 3,000 sq m in total, the 6.7 hectare Colburn Business Park near Catterick in North Yorkshire will provide high quality accommodation. The speed and efficiency that the Multibeam provides makes it ideal for a project that requires a 'right first time' approach.



Debenham's Peterborough

Over 67,000 sq m in total, the site includes a vast warehouse featuring Multibeam purlins and rails integral to its roof, an impressive four spans wide. Timing of production and delivery is crucial in order to coincide with the construction of the primary steelwork for the walls and roof structure.



Index

A		Section Properties	86
Angle cleats	85,120	Spanning Systems	65
Anti-sag tie requirements Purlins	10	Diagonal Tie Wire	76
Anti-sag tie requirements Rails	66	Firewall	74
Apex ties	23,29	Rafter stays	75
AUTOFORM® Multichannel	97,108,118	Rail Connection	72
B		Rod Diagonal with G140/150	74
Base cleats Multichannel	110	Sleeves	72
Bottom strut bracket	76,85	Tube Strut Arrangement	76
Boundary Wall	52,53	Multichannel	
Brickwork restraint	103	Corner - External	105
C		- Internal	105
Cantilevers	17,18	Diagonal Tie Wire	108
Case Studies	71,105,113,136	Firewall	106
Certification	3,8,50,64,96	Stanchion stays	107
Clamp plates	29,83	Rail Connection	104
Cleader angles	31	Rod Diagonal with G140/150	106
Cleats (see also Multicleats)	25,26,27,79,80,81,115,116,117	Sleeves	104
Columns	110	Corners	73,105
Compound Multichannels	103	Customer Service	3
Construction Details			
Roof Purlins			
Apex Restraint	23	D	
Cantilever	18	Design & Ordering	
Diagonal Tie Wire	23	Hole Arrangements - Multibeam	134,135
Flat Roof/Shallow Roof arrangement	20	- Multichannel	136,137
Heavy Duty Flat Roof Restraint	20	Overview	134
Multicleats	16	Software	134
Multilok Ties	21	Diagonal tie wires	13,23,31,67,76,84,108,120
Stanchion stays	19	Door openings	102,109
Sleeves	17	E	
Tiled Roofs	22	Eaves Beam	
Tubular Ties	21	Dimensions & References	56
Eaves Beam			
Connection to Main Frame - Boundary Wall Gutter	52	Load Charts	60,61
- External Gutter	52	Material Specification	50
Restraint Connection - Boundary Wall Gutter	53	Overview	50
- External Gutter	54	Range	50
Parapet	55	Restraint Systems	51
Mono Pitch Roof - High Eaves	55	Section Properties	59
Cladding Rails			
Applications	64	External Gutters	52,53,54
Case Study	71	F	
Corner - External	73	Firewall	70,99
- Internal	73	Flange Variations	56
Dimensions & References	78	Flat roofs	15,20
Load Tables		Floor beams Mezzanine floors	103,111,112
Double Span - Vertical Cladding	87,88,89,90	G	
- Horizontal Cladding	91,92,93	Gable Posts	103,110
Material Specification	64	H	
Overview	64	Hole Arrangements - Multibeam	
Range	64	- Multichannel	134,135
Restrains			
Firewall	70	Horizontal cladding	68,69,100,101
Horizontally Laid Cladding	68,69	Horizontal panel vertical support	74,84,106,121
Overview	66		
Vertically Laid Cladding	67		

L	
Load Tables	
Eaves Beam	60,61
Multichannel	
Brickwork Restraints	123,124,125
Double Span - Vertical Cladding	126,127
- Horizontal Cladding	127,128
Floor Beams: - Single span between steel	129
- Single span with cleats	130,131,132
- Double span with cleats	133
Purlins	
Double Span	33,34,35,36,37
Double Span Continuous System	38,39,40,41,42
Single Span Continuous System	43,44,45,46,47
Tiled Roofs	37
Cladding Rails	
Double Span - Vertical Cladding	87,88,89,90
- Horizontal Cladding	91,92,93
M	
Material Specification	8,50,64,96
Mezzanine Floors	103,111,112
MTC cleats (also see Angle cleats)	85,120
Multibracket	31,85,121
Multichannel	
Applications	
Parapets	102
Door & Window Openings	102
Mezzanine Floors	103
Brickwork Restraints	103
Gable Posts	103
General Engineering	103
Autoforms®	97,118
Case Study	113
Load Tables	
Brickwork Restraints	123,124,125,126
Double Span	
- Vertical Cladding	127
- Horizontal Cladding	128,129
Floor Beams	
- Single Span between Steel	130
- Single Span on cleats	131
Material Specification	96
Notches	97,118
Overview	96
Range	96
Restraints - Firewall	99
Restraints - Vertically Laid Cladding	98
Restraints - Horizontally Laid Cladding	100,101
Section Properties	122
Why Multichannel	97
Multicleats (also see cleats)	25,26,27,79,80,81,115,116,117
Multilok Ties	21,29
N	
Notches	97,118
O	
Openings	109
Order Forms	See separate handbook ref: P228
Ordering and Detailing	132,133,134,135

P	
Parapet	55,102
Products Overview	2,4,5
Purlins	
Anti Sag Requirements	10
Applications	8
Dimensions & References	24
Load Tables	
Double Span	33,34,35,36,37
Double Span Continuous System	38,39,40,41,42
Single Span Continuous System	43,44,45,46,47
Tiled Roofs	37
Material Specification	8
Overview	8
Range	8
Restraints	
Built Up	
- Membrane Flat Roofs	15
- Roofing	13
- Standing Seam	15
Clip Fix	13
Downslope Ties (through fix)	13
Flat Roofs	15
Insulated Panels	13
Low Pitch Roof	15
Rooflights	14
Secret & Clip Fix	13
Secret Fix Insulated Panels	13
Through Fix Roofing	13
Tiled Roof	14
Section Properties	32
Spanning Systems	9
Tie Arrangements	11
R	
Rafter Stays	19,30
Rafter Stays Capacities	87
Recycling	8,64,96
Rod Diagonals	31,85,121
Roof cladding types	12
S	
SCILGA accreditation	2
Section Properties	
Purlins	32
Eaves Beam	59
Cladding Rails	86
Multichannel	122
Sleeves	9,17,28,72,82,118
Stanchion stays	84,120
Stubs	84,121
Sustainability	8,50,64,96
Stantion Stays Capacities	125
T	
Tiled Roofs	14,22
Tube Struts	11,21,29,76,83,119
V	
Vertical Cladding	67,98
W	
Window openings	102,109

Structural Products Software

Toolkit Design Software for Structural Products

Toolkit Design Software

To satisfy the growing demand for accurate and comprehensive information and simplify the detailing and ordering of components, Kingspan Structural Products have produced the Toolkit CD. The CD contains information in an easily accessible format. Contents include:

Multibeam Design Software for Purlin and Rail Systems

A comprehensive software program for the design engineer and specifier, featuring Multibeam Purlins and Cladding Rails. The design software has been extended to include support systems for Horizontal cladding (both horizontal Multibeam and Multichannel). Cantilever sections, Eaves Beams, Parapet posts and stepped wind loading for continuous design as well as the previous design options, single span and double span design for both conventional and continuous systems, plus automatic Purlin spacing in snow load applications.

The Toolkit program also assists users in meeting the requirements of the latest Wind Code, BS 6399-2 1997 part 2. Toolkit features integrated information derived from Ordnance Survey with the latest BREVe topographical information and BRECP external coefficients. These features enable users to take full account of the minimum distances to sea and the lay of the land surrounding the proposed construction site. It then provides fully calculated wind pressure data for the building from each of twelve wind directions, and applies it to sides, corners and roof of the structure.

Multichannel Design Software for Structural Solutions

A useful design software program for the specification and use of the Multichannel range of galvanised pre-engineered cold formed channel sections.

The construction applications featured within the program include cladding rail design, mezzanine floor beam design and column design.

For copies of the Toolkit CD please contact our Customer Services on: 01944 712000 or visit www.kingspanstructural.com to download from the website.

Multideck Design Software for Composite Floor Design

This advanced package for the structural analysis and design of composite slabs using Multideck has now been made even easier to use with the inclusion of an all new design wizard which guides you through the design and selection of the correct Multideck product for your particular application. The Multideck product is a high performance galvanised steel floor decking which provides economies of concrete volumes.

Detailing & Ordering Software for Kingspan Structural Products

Kingspan-Wizard has been updated with more detailing options and remains a fast and easy to use program for the detailing and ordering of Kingspan products including: Multibeam Purlins and Rails, Multichannel, Multibeam Eaves Beam, Multibeam Cleaders and all other related components.

Kingspan Technical Literature

This library of Kingspan technical literature now contains the very latest version of the Multibeam Purlin, Rail and Multichannel Handbook with greatly enhanced functionality. Also included is the technical handbook for Multideck Floordecking featuring product applications, dimensions and construction details.

Toolkit now offers the opportunity to design a full roof solution due to it's interactive link with CSC Fastrak, providing a quicker and more efficient design.





Kingspan Toolkit Software

The Toolkit series has become the leading cold rolled steel and floor decking design software in the industry and is now used by structural engineers in over 1000 practices in the UK.

The structural design software has been used industry wide to save valuable design time.

The contents of this Technical Handbook and CD are meant as a general introduction to Kingspan Structural Products and any purchaser, specifier or user retains the entire responsibility for satisfying himself, independently of anything herein, as to the suitability or fitness for purpose of any Kingspan product or system.

Kingspan Structural Product Range

Multibeam Technical Handbook

Kingspan Structural Products produce a complete range of pre-engineered cold formed products for modern industrial and commercial building construction.



Composite Slab Case Study

Dramix Steel fibres with Multideck profiles have been proven through testing to achieve full fire performance for 1, 1.5 and 2 hours. The use of a Dramix Steel Fibre reinforced concrete slab provides a “pre-reinforced” concrete slab – no mesh has to be installed

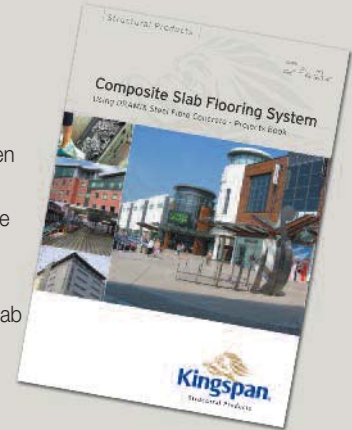

Multideck Technical Handbook

Multideck is a high performance profiled galvanised steel deck for use in the construction of composite floor slabs. This publication contains complete technical information on the Multideck products produced by Kingspan Structural Products.



Kingspan Toolkit Software

The Toolkit series has become the leading cold rolled steel and floor decking design software in the industry and is now used by structural engineers in over 1000 practices in the UK. The structural design software has been used industry wide to save valuable design time.



Kingspan Structural Products

Sherburn, Malton, North Yorkshire, YO17 8PQ, England
Tel: 01944 712000 Sales fax: 01944 710830 Customer Services fax: 01944 710941 Technical fax: 01944 711649
Email: marketing@kingspanstructural.co.uk

visit our website kingspanstructural.com or our group website kingspan.com

Due to our continuing policy of development and improvement we reserve the right to alter and amend the specification as shown in this literature.